



Informazioni su questo libro

Si tratta della copia digitale di un libro che per generazioni è stato conservata negli scaffali di una biblioteca prima di essere digitalizzato da Google nell'ambito del progetto volto a rendere disponibili online i libri di tutto il mondo.

Ha sopravvissuto abbastanza per non essere più protetto dai diritti di copyright e diventare di pubblico dominio. Un libro di pubblico dominio è un libro che non è mai stato protetto dal copyright o i cui termini legali di copyright sono scaduti. La classificazione di un libro come di pubblico dominio può variare da paese a paese. I libri di pubblico dominio sono l'anello di congiunzione con il passato, rappresentano un patrimonio storico, culturale e di conoscenza spesso difficile da scoprire.

Commenti, note e altre annotazioni a margine presenti nel volume originale compariranno in questo file, come testimonianza del lungo viaggio percorso dal libro, dall'editore originale alla biblioteca, per giungere fino a te.

Linee guide per l'utilizzo

Google è orgoglioso di essere il partner delle biblioteche per digitalizzare i materiali di pubblico dominio e renderli universalmente disponibili. I libri di pubblico dominio appartengono al pubblico e noi ne siamo solamente i custodi. Tuttavia questo lavoro è oneroso, pertanto, per poter continuare ad offrire questo servizio abbiamo preso alcune iniziative per impedire l'utilizzo illecito da parte di soggetti commerciali, compresa l'imposizione di restrizioni sull'invio di query automatizzate.

Inoltre ti chiediamo di:

- + *Non fare un uso commerciale di questi file* Abbiamo concepito Google Ricerca Libri per l'uso da parte dei singoli utenti privati e ti chiediamo di utilizzare questi file per uso personale e non a fini commerciali.
- + *Non inviare query automatizzate* Non inviare a Google query automatizzate di alcun tipo. Se stai effettuando delle ricerche nel campo della traduzione automatica, del riconoscimento ottico dei caratteri (OCR) o in altri campi dove necessiti di utilizzare grandi quantità di testo, ti invitiamo a contattarci. Incoraggiamo l'uso dei materiali di pubblico dominio per questi scopi e potremmo esserti di aiuto.
- + *Conserva la filigrana* La "filigrana" (watermark) di Google che compare in ciascun file è essenziale per informare gli utenti su questo progetto e aiutarli a trovare materiali aggiuntivi tramite Google Ricerca Libri. Non rimuoverla.
- + *Fanne un uso legale* Indipendentemente dall'utilizzo che ne farai, ricordati che è tua responsabilità accertarti di farne un uso legale. Non dare per scontato che, poiché un libro è di pubblico dominio per gli utenti degli Stati Uniti, sia di pubblico dominio anche per gli utenti di altri paesi. I criteri che stabiliscono se un libro è protetto da copyright variano da Paese a Paese e non possiamo offrire indicazioni se un determinato uso del libro è consentito. Non dare per scontato che poiché un libro compare in Google Ricerca Libri ciò significhi che può essere utilizzato in qualsiasi modo e in qualsiasi Paese del mondo. Le sanzioni per le violazioni del copyright possono essere molto severe.

Informazioni su Google Ricerca Libri

La missione di Google è organizzare le informazioni a livello mondiale e renderle universalmente accessibili e fruibili. Google Ricerca Libri aiuta i lettori a scoprire i libri di tutto il mondo e consente ad autori ed editori di raggiungere un pubblico più ampio. Puoi effettuare una ricerca sul Web nell'intero testo di questo libro da <http://books.google.com>



B⁶ 21. — 15.



H. 1. S.

ATLANTE

DI

MACCHINE A VAPORE E FERROVIE

CON

LEGGENDA,

ad uso particolarmente degli Allievi della R. Scuola d'applicazione per gli Ingegneri in Torino, utiie anche agli Allievi delle altre scuole analoghe del Regno, agli Ingegneri meccanici, agli Ingegneri del materiale e trazione delle strade ferrate ed agli Allievi della Sezione di meccanica degli Istituti tecnici e professionali.

OPERA COMPILATA DALL'

Ingegnere AGOSTINO CAVALLERO,

PROFESSORE ORDINARIO DI MACCHINE A VAPORE E FERROVIE DELLA R. SCUOLA D'APPLICAZIONE PER GLI INGEGNERI IN TORINO
E MEMBRO DELLA COMMISSIONE GOVERNATIVA PER L'ESAME DEI MACCHINISTI E DEL MATERIALE DELLE FERROVIE DELL'ALTA ITALIA,

colla collaborazione de' suoi Allievi.

SECONDA EDIZIONE

interamente rifusa, ridotta al corrente degli ultimi perfezionamenti e corredata di un indice alfabetico-terminologico colle voci corrispondenti nelle lingue francese, tedesca ed inglese.

Due volumi in-8 grande, l'uno di testo a doppia colonna, e l'altro di 74 tavole litografate.



VOLUME II — TAVOLE.

TORINO

LITOGRAFIA PIETRO BRIOLA EDITORE

Via S. Francesco d'Assisi, 22.

1870

ATLANTE
DI
MACCHINE A VAPORE E FERROVIE
CON
LEGGENDA.

ATLANTE

DI

MACCHINE A VAPORE E FERROVIE

CON

LEGGENDA,

ad uso particolarmente degli Allievi della R. Scuola d'applicazione per gli Ingegneri in Torino,
utile anche agli Allievi delle altre scuole analoghe del Regno, agli Ingegneri meccanici, agli Ingegneri del materiale
e trazione delle strade ferrate ed agli Allievi della Sezione di meccanica degli Istituti tecnici e professionali.

OPERA COMPILATA DALL'

Ingegnere AGOSTINO CAVALLERO,

PROFESSORE ORDINARIO DI MACCHINE A VAPORE E FERROVIE DELLA R. SCUOLA D'APPLICAZIONE PER GLI INGEGNERI IN TORINO
E MEMBRO DELLA COMMISSIONE GOVERNATIVA PER L'ESAME DEI MACCHINISTI E DEL MATERIALE DELLE FERROVIE DELL'ALTA ITALIA.

colla collaborazione de' suoi Allievi.

SECONDA EDIZIONE

interamente rifusa, ridotta al corrente degli ultimi perfezionamenti e corredata di un indice alfabetico-terminologico
colle voci corrispondenti nelle lingue francese, tedesca ed inglese.

Due volumi in-8 grande, l'uno di testo a doppia colonna, e l'altro di 74 tavole litografate.

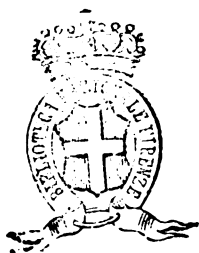

VOLUME II — TAVOLE.

TORINO

LITOGRAFIA PIETRO BRIOLA EDITORE

Via S. Francesco d'Assisi, 22.

1870

INDICE DELLE TAVOLE



- I. Storia delle macchine a vapore stazionarie, locomotive e di navigazione.
- II e III. Apparecchi relativi allo studio delle proprietà fisico-meccaniche dei gaz e vapori.
- IV. Apparecchi riferentisi allo studio del movimento dei gaz e vapori; anemometro di Newman; ventilatori.
- V. Compressore idropneumatico a colonna di Grandis, Grattoni e Sommeiller; regolatore d'aria di Sommeiller.
- VI. Compressore idropneumatico a tromba e macchina aspirante a campana, con motore a colonna d'acqua, di Sommeiller.
- VII. Perforatore ad aria compressa di Sommeiller; piano inclinato automotore del cantiere di Modane.
- VIII. Fabbrica di gaz-luce della città di Milano; sistemi di congiunzione dei tubi ed innesto a sella delle diramazioni nelle condotte di gaz; sifoni.
- IX. Forno di distillazione del carbon fossile a sette storte e condensatore a colonne della Società Italiana per il gaz in Torino.
- X. Estrattore, a stantuffo ed a vapore, del gaz dalle storte di distillazione di Arson e Gargan; regolatore di pressione a cono di Clegg.
- XI. Piccolo gazometro a sospensione e valvola idraulica a stantuffo di Leroux; gazometri semplice e telescopico della Società Italiana per il gaz in Torino; valvola idraulica a campana.
- XII. Colonna a coke; purificatore a calce; valvola idraulica semplice a campana; regolatore di pressione dell'antica Società del gaz portatile in Torino; misuratore del gaz-luce.
- XIII. Camini in muratura e metallici, registri per regolarne il tirante; apparecchi di presa d'aria e per difendere il tirante dei forni dal vento.
- XIV. Sbarre di graticola, porte di focolari; forni a fiamma rovesciata, a graticola inclinata, a due graticole, con graticola a gradini e ad alimentazione continua.
- XV. Forni fumivori ad introduzione d'aria sulla fiamma, ad alimentazione continua, a graticola girante, ad alimentazione inferiore, a più focolari, ad iniezione di vapore, a petrolio ed a gaz.
- XVI. Chiodatura delle caldaie a vapore, coperchi autoclavi, e valvole di presa del vapore.
- XVII. Indicatori del livello d'acqua a chiavi, a galleggiante, magnetico ed a tubo di vetro; salinometro delle caldaie a vapore marine.
- XVIII. Manometri ad aria libera, ad aria compressa e metallici; indicatore metallico del vuoto e pirometro metallico.
- XIX. Valvole di sicurezza a carico diretto, a leva, con bilancia a molla, a scatto ed a piastra fusibile.

- XX. Apparecchi d'alimentazione delle caldaie a vapore a galleggiante, senza tromba e di Gargan; trombe alimentari; iniettori Giffard, Delpèche e Turck.
- XXI. Caldaia a vapore a bassa pressione di Watt; maniere diverse di riscaldamento delle caldaie cilindriche.
- XXII. Caldaie a vapore ad uno ed a due bollitori, a tubi di riscaldamento laterali di Farcot.
- XXIII. Caldaie a tubi di riscaldamento inferiori, a condotto del fumo ed a focolare interni, con soprariscaldatore del vapore.
- XXIV. Caldaie tubolari a tirante meccanico di Molinos e Pronnier, delle locomotive e marine.
- XXV. Caldaie a vapore a serpentino, a diafragmi, inesplosibile di Belleville, verticali di Beslay e Nasmith.
- XXVI. Motori ad aria calda, senza rigeneratore del calore, di Ericsson e di Laubereau; motore a gaz di Lenoir.
- XXVII. Motori ad aria calda ed a calore rigenerato di Ericsson e di Stirling, a focolare interno di Belou; motori a gaz di Hugon e di Otto e Langen.
- XXVIII. Valvole di distribuzione del vapore di Watt ed a cassetto; diagrammi della distribuzione ellittico e polare; valvole per macchine oscillanti.
- XXIX. Valvole di distribuzione con registro d'espansione fissa; espansioni variabili di Meyer e di Farcot; valvole a chiave ed a disco.
- XXX. Valvole di Cornwall; meccanismo d'inversione del moto ad aste indipendenti; settore di Stephenson e relativo diagramma.
- XXXI. Settore rettilineo di Allan e relativo diagramma ellittico.
- XXXII. Disposizioni diverse del meccanismo di distribuzione del vapore delle locomotive.
- XXXIII. Condensatori a contatto diretto ed a tubi refrigeranti; condensatore-eiettore di Morton.
- XXXIV. Macchina a vapore, a bassa pressione ed a doppio effetto, di Watt.
- XXXV. Macchina a vapore verticale, a trasmissione diretta, di Martin.
- XXXVI. Macchina a vapore orizzontale, ad espansione variabile e senza condensazione, della stamperia Favale in Torino, costrutta da Escher Wyss di Zurigo.
- XXXVII. Macchina a vapore a cilindro oscillante di Cavè.
- XXXVIII. Macchina a vapore a due cilindri inclinati, con espansione variabile regolata automaticamente, di Leconte e Delpèche.
- XXXIX. Macchina a vapore a due cilindri verticali del sistema Wölf con bilanciere.
- XL. Macchina a vapore portatile della R. Scuola d'Applicazione per gli Ingegneri in Torino.
- XLI. Macchine a vapore locomobili orizzontali, con apparecchio riscaldatore dell'acqua di alimentazione, di Cail, e con meccanismo motore verticale di Tuxford.
- XLII. Macchine a vapore con gambo snodato dello stantuffo motore, a cilindro articolato di Faivre, a cilindro curvilineo, con stantuffo a fodero e rotatorie.
- XLIII. Macchina a vapore marina a due cilindri oscillanti, della forza di 500 cavalli nominali, per battello a ruote.
- XLIV. Macchina a vapore marina con tirante motore capovolto, della forza di 1000 cavalli nominali, per battello ad elice.
- XLV. Macchina a vapore a semplice effetto, del sistema Cornwall, per l'innalzamento dell'acqua.
- XLVI. Tromba a vapore e macchina soffiante a vapore orizzontale con valvola dell'aria a cassetto.
- XLVII. Maglio a vapore e grù locomobile a vapore.
- XLVIII. Indicatore delle pressioni di Watt e di Macnaught, noveratore meccanico dei giri, diagrammi delle macchine a gaz ed a vapore.
- XLIX. Profili di rotaie; cuscinetti intermedi e d'unione; stecche, stecche sospese, a suola ed a manicotto; cuneo elastico d'acciaio.
- L. Rotaie a ponte di Brunel ed a sella di Barlow, ferrovie metalliche, passaggi a livello e respintori.

- LI. Sviatoi doppio e triplo, incrociamenti di via a cuore con e senza cuscinetti, posa d'un cangiamento di via triplice.
- LII. Piattaforma girevole di diametro m. 4,50 e grù idraulica per l'alimentazione delle locomotive.
- LIII. Traversate e piattaforma girevole di grande diametro per locomotive unite al loro carro di scorta.
- LIV. Carro di servizio per rimessa e segnale a disco.
- LV e LVI. Piano della stazione delle ferrovie dell'Alta Italia in Milano.
- LVII. Parti dei veicoli delle ferrovie: ruote, sale, scatole del grasso, piastre di guardia, paracolpi, molle di trazione di caucciù e catene di sicurezza.
- LVIII. Parti dei veicoli delle ferrovie: molle di sospensione, molla di trazione a spirale, tenditore, gancio e catena di trazione.
- LIX. Carrozza mista di prima e seconda classe delle ferrovie dell'Alta Italia (tipo lombardo).
- LX. Carrozza di terza classe, con freno, delle ferrovie dell'Alta Italia (tipo lombardo).
- LXI. Bagagliaio, o carro pel trasporto delle merci celeri, con freno, delle ferrovie dell'Alta Italia (tipo lombardo).
- LXII. Carri coperti per merci e bestiame, carro pel trasporto dei cavalli, del ballasto e del carbone, carro piatto, trasversa girevole pel trasporto delle travi e treno, ad intelaiatura metallica, dei veicoli a tre assi delle ferrovie dell'Alta Italia.
- LXIII. Sale e ruote motrici delle locomotive, scatole dell'olio delle medesime e del loro carro di scorta.
- LXIV. Tiranti motori e d'accoppiamento, valvole di presa e di scarica del vapore, fischietti e chiavi diverse delle caldaie delle locomotive.
- LXV. Cilindri e stantuffi motori delle locomotive.
- LXVI, LXVII, LXVIII e LXIX. Locomotiva Gouin, a cilindri interni ed a quattro ruote accoppiate, delle ferrovie dell'Alta Italia (tipo dell'anno 1862); molle di sospensione delle locomotive.
- LXX. Carro di scorta della locomotiva Gouin: valvole di presa d'acqua e tubi d'accoppiamento.
- LXXI. Tipi diversi di macchine a vapore locomotive.
- LXXII. Freno a porta-ceppi fissi di Pansa; freno a controvapore e meccanismo d'inversione del moto a vite delle locomotive.
- LXXIII. Locomotiva ad aderenza artificiale di Fell.
- LXXIV. Locomotore funicolare di Tommaso Agudio.



Fig. 1.

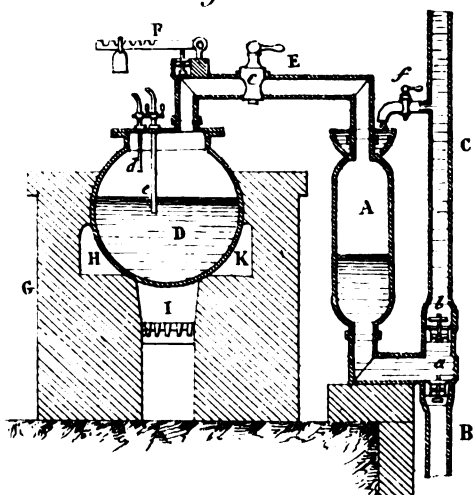

Fig. 2.

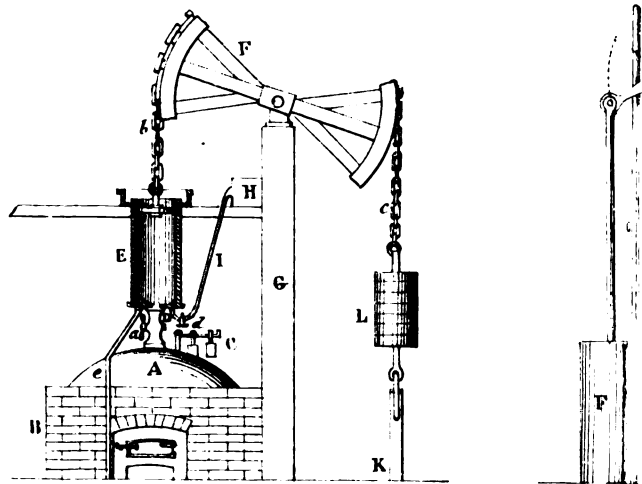

Fig. 6.

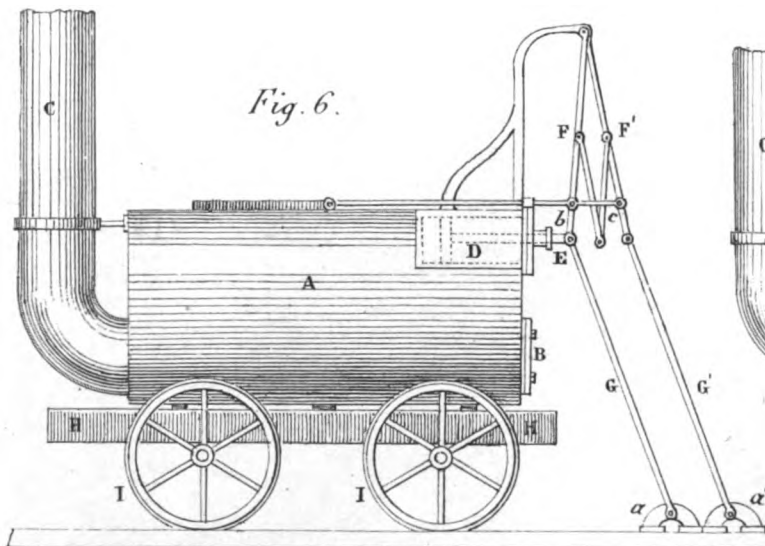

Fig. 5.

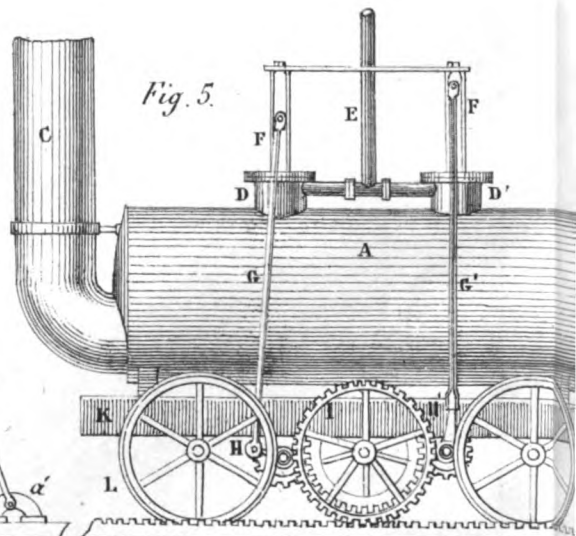

Fig. 8.

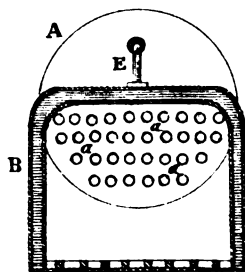

Fig. 7.

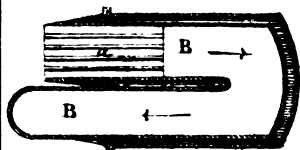

Fig. 10.

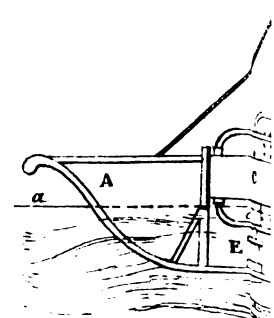
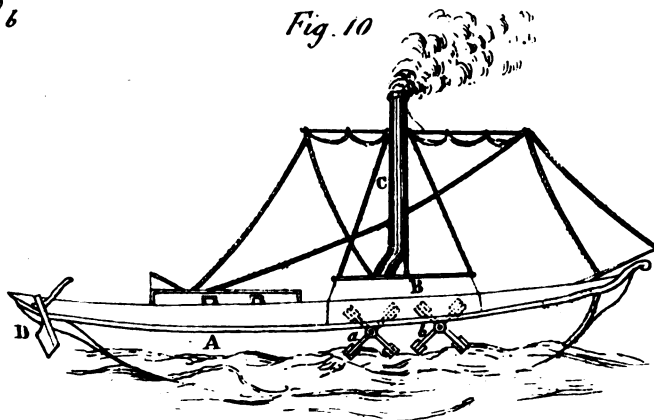

Fig. 3.

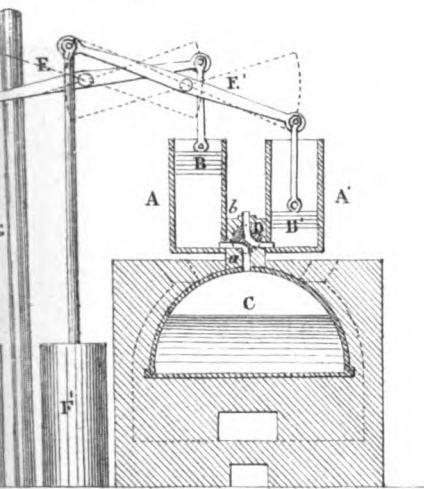

Fig. 4.

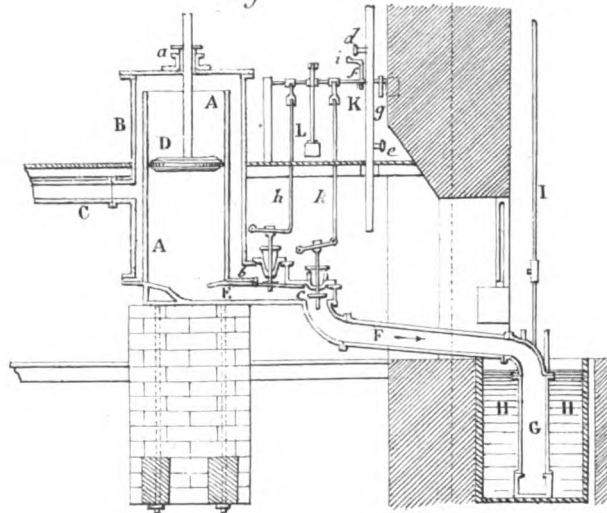

Fig. 7a

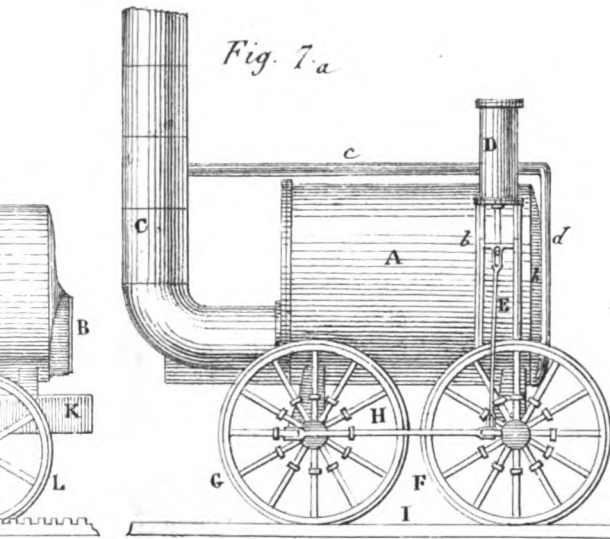

Fig. 8a

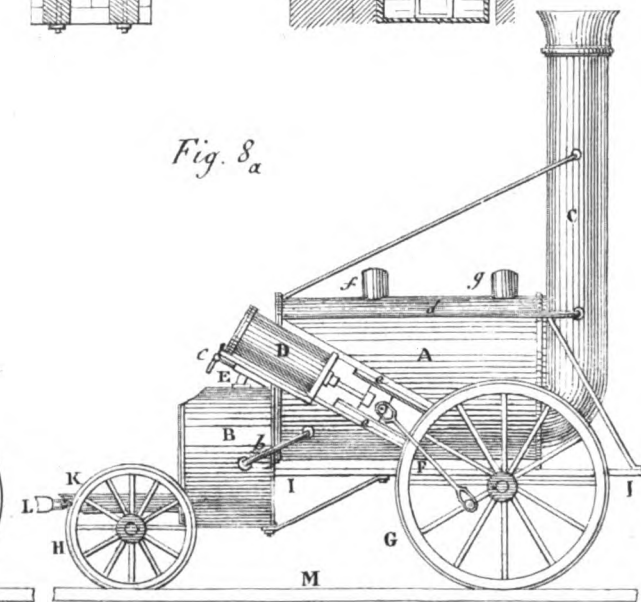

Fig. 9.

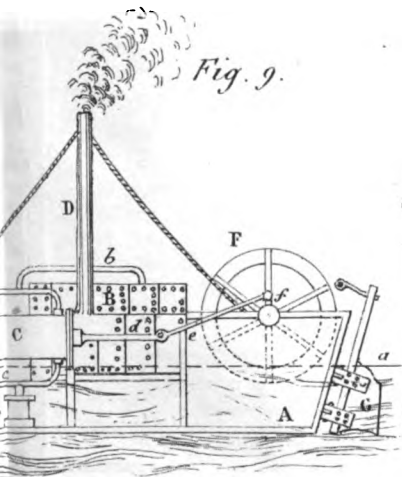
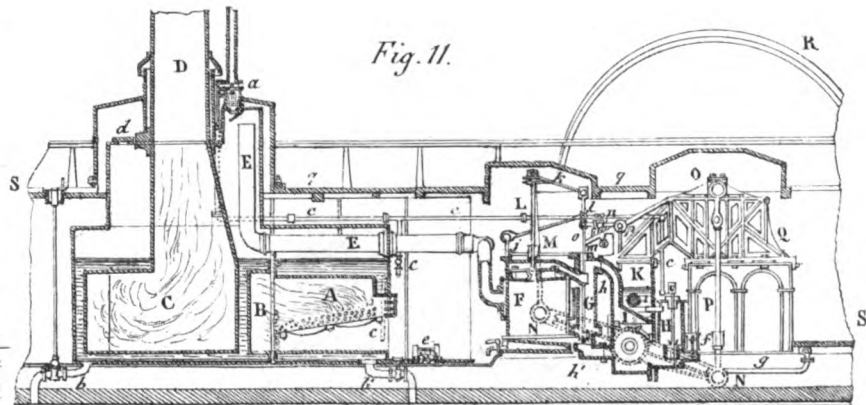
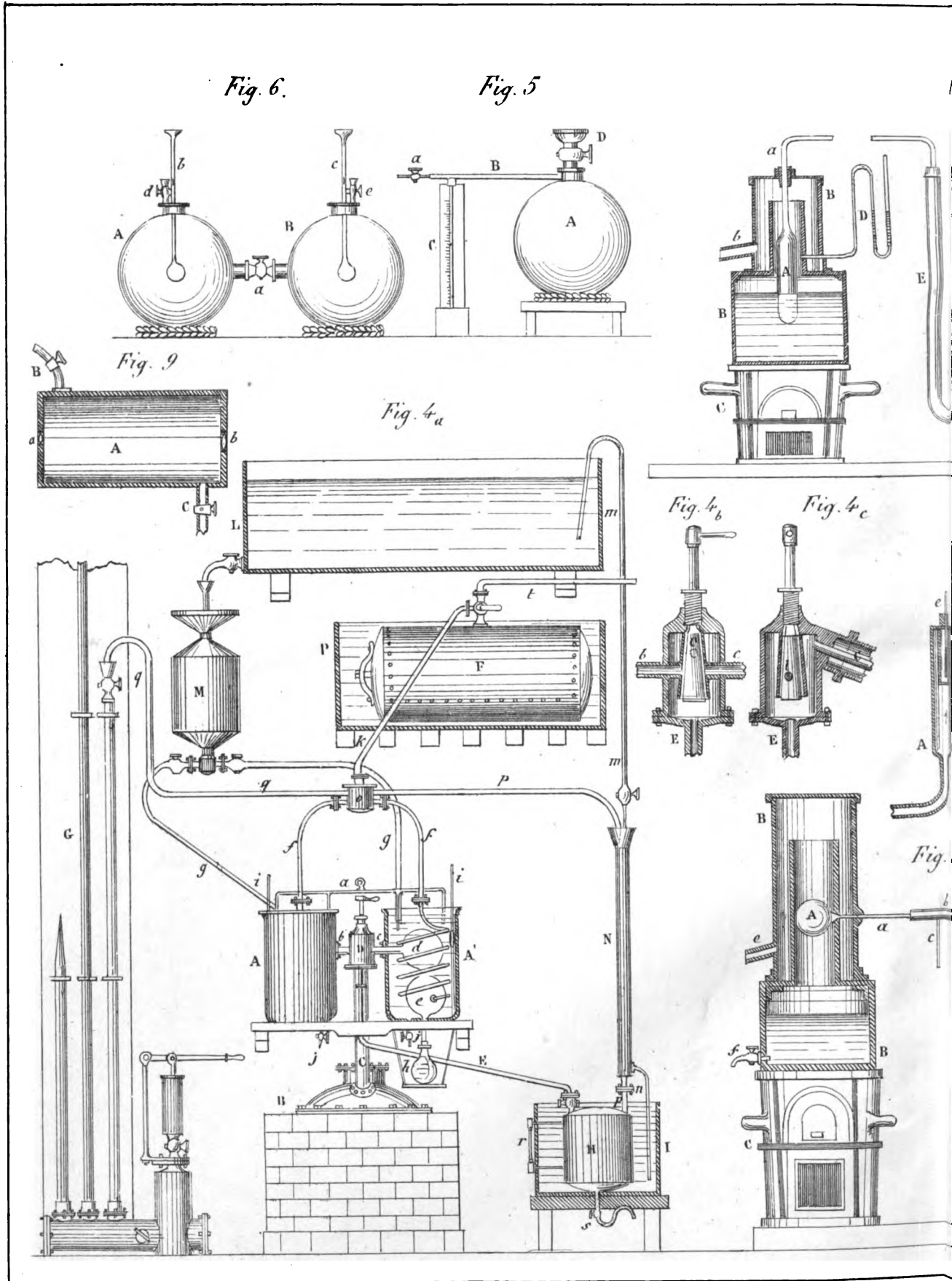
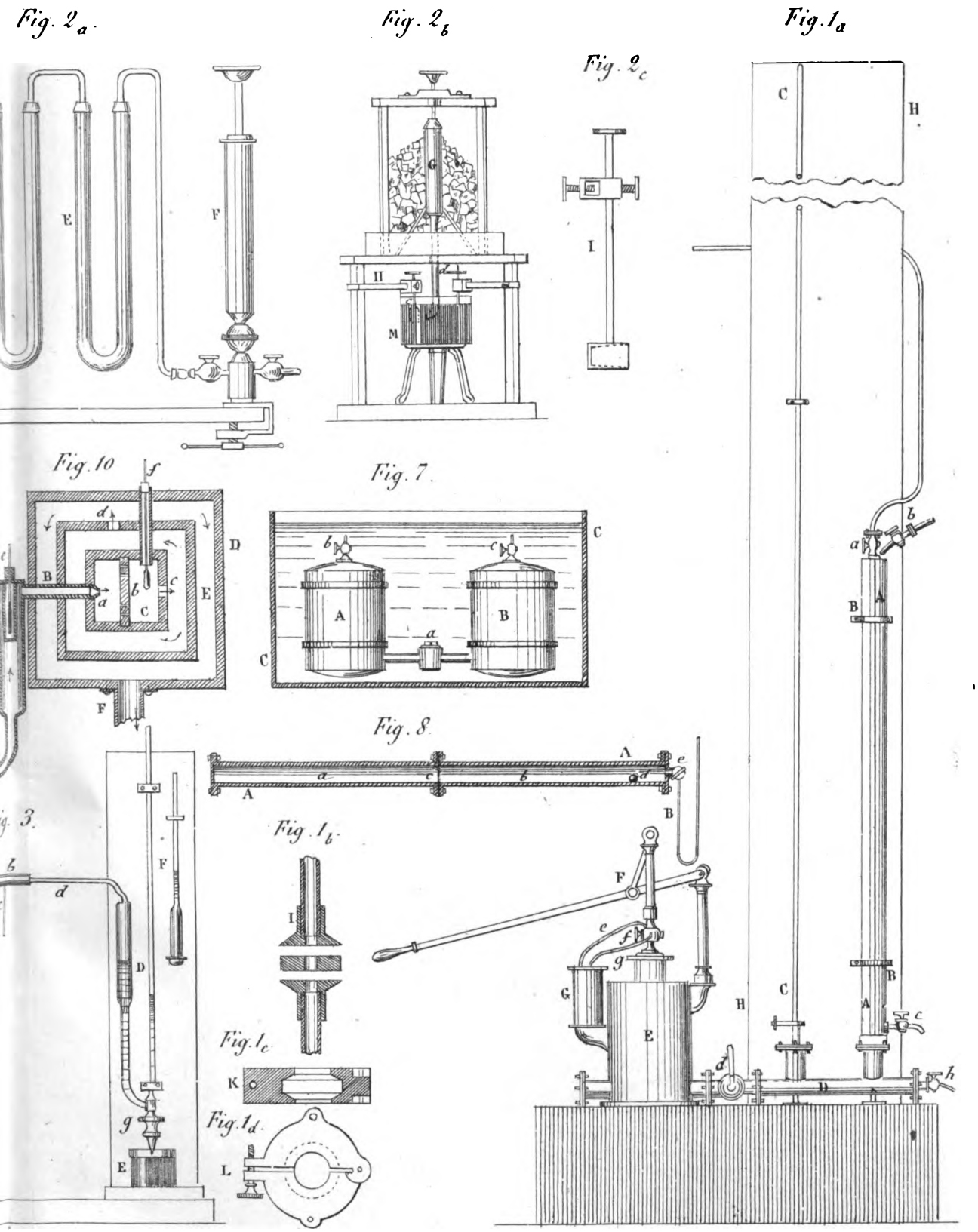

Fig. 11.







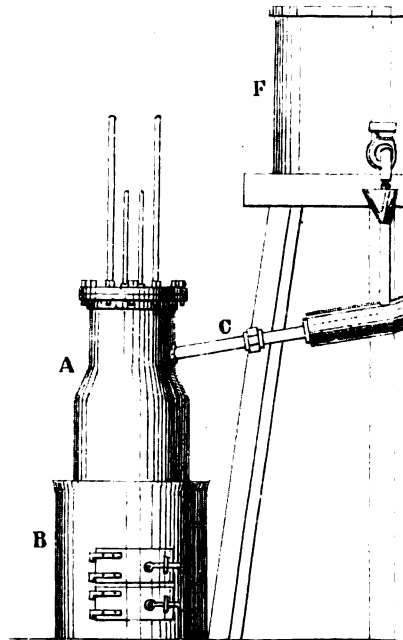
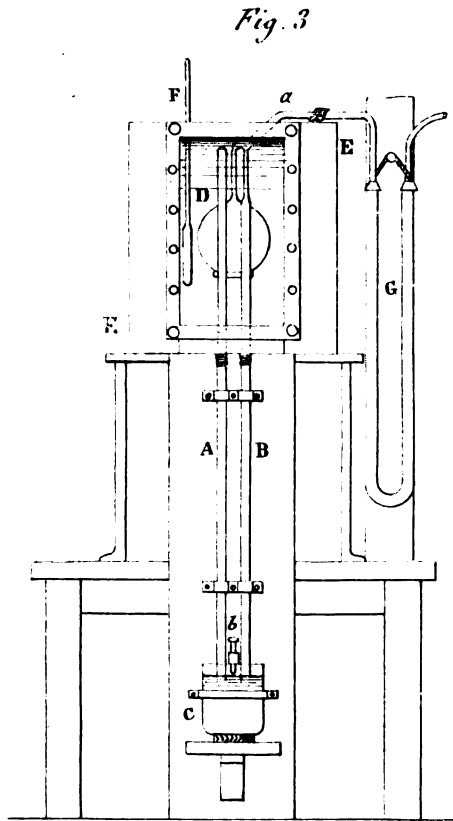
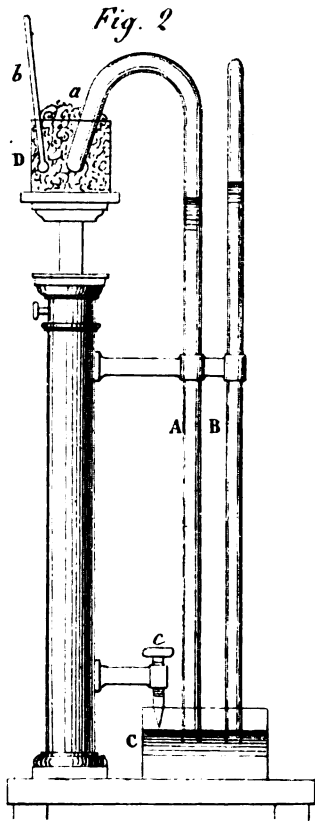

Fig. 1a

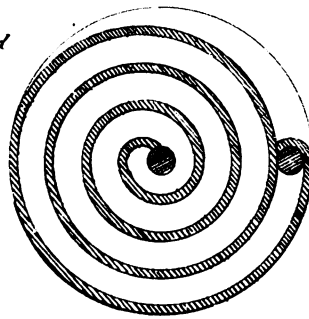

Fig. 1c

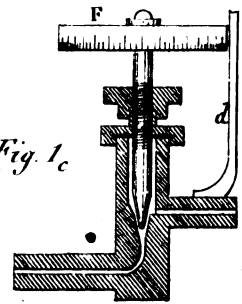

Fig. 1d

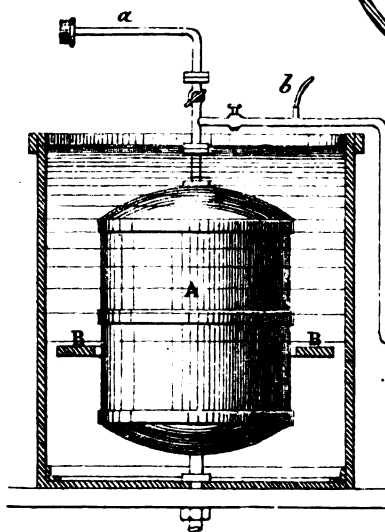

Fig. 1a

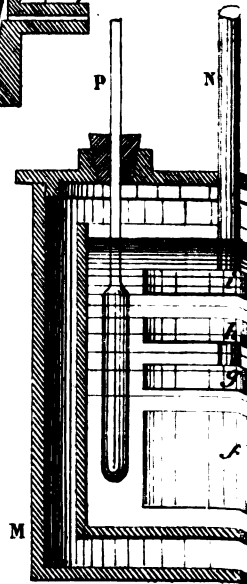
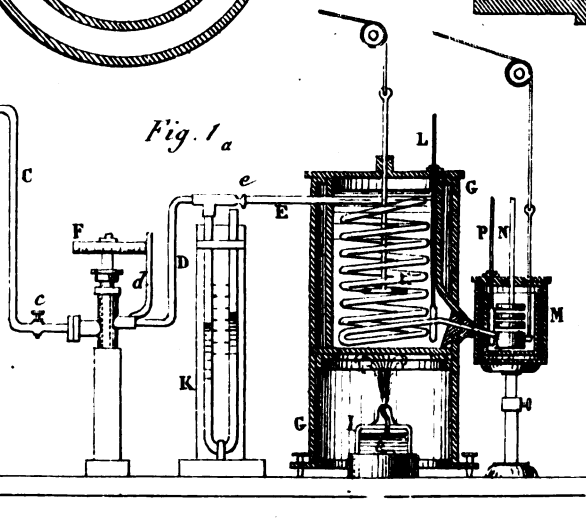

Fig. 4.

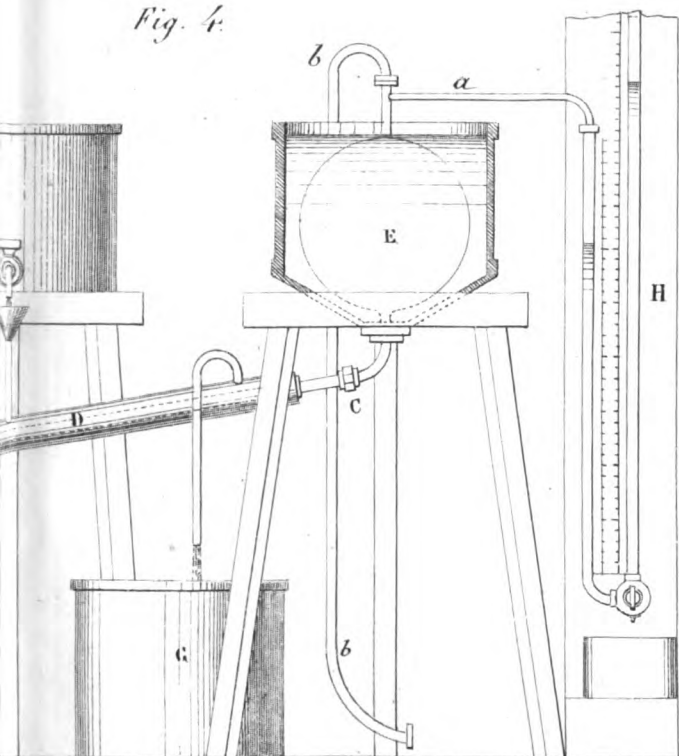

Fig. 7. Scala di 1/10

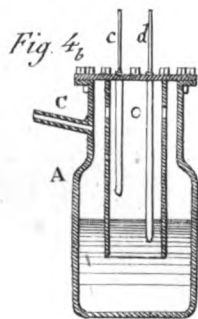
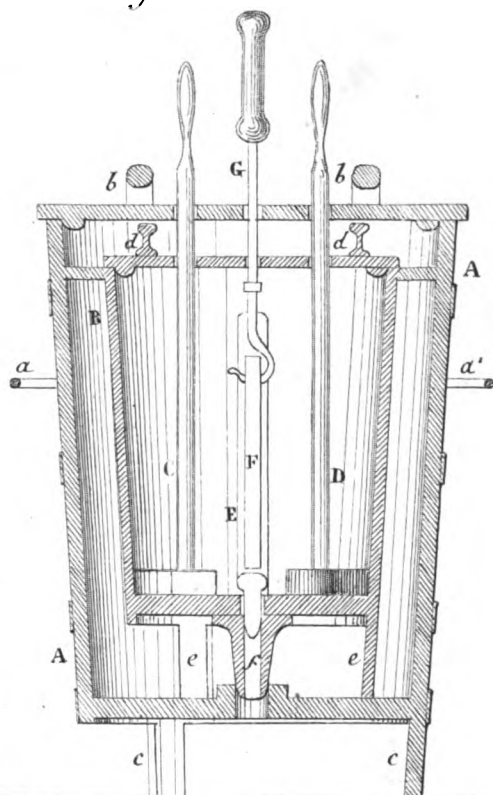

Fig. 5.

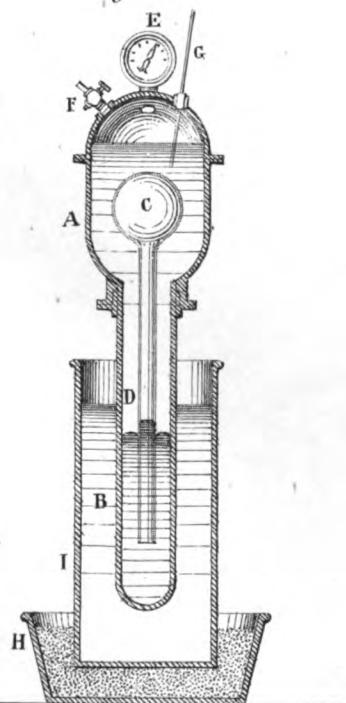
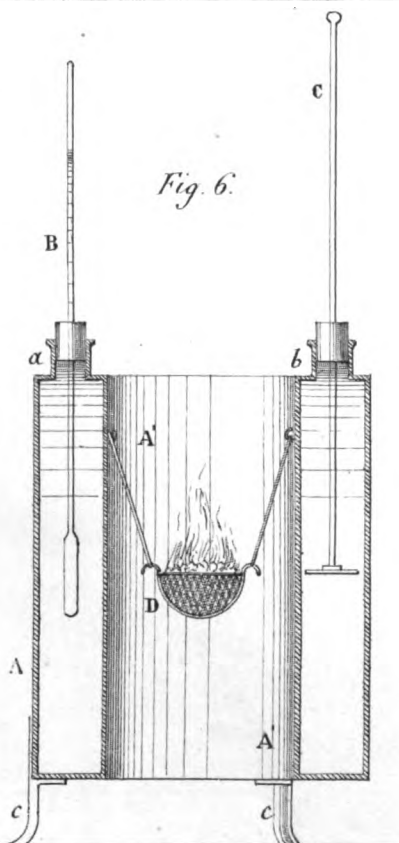
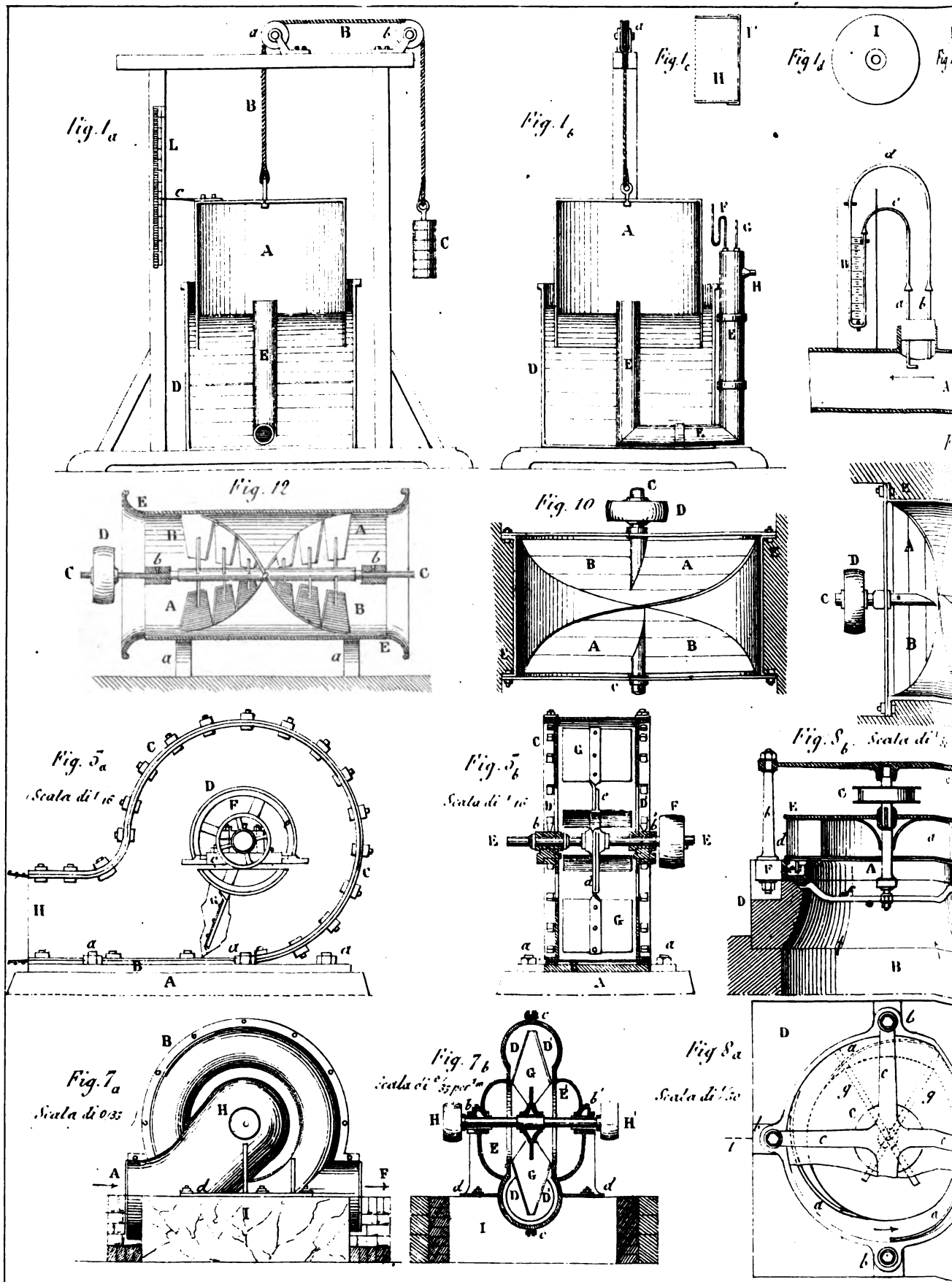
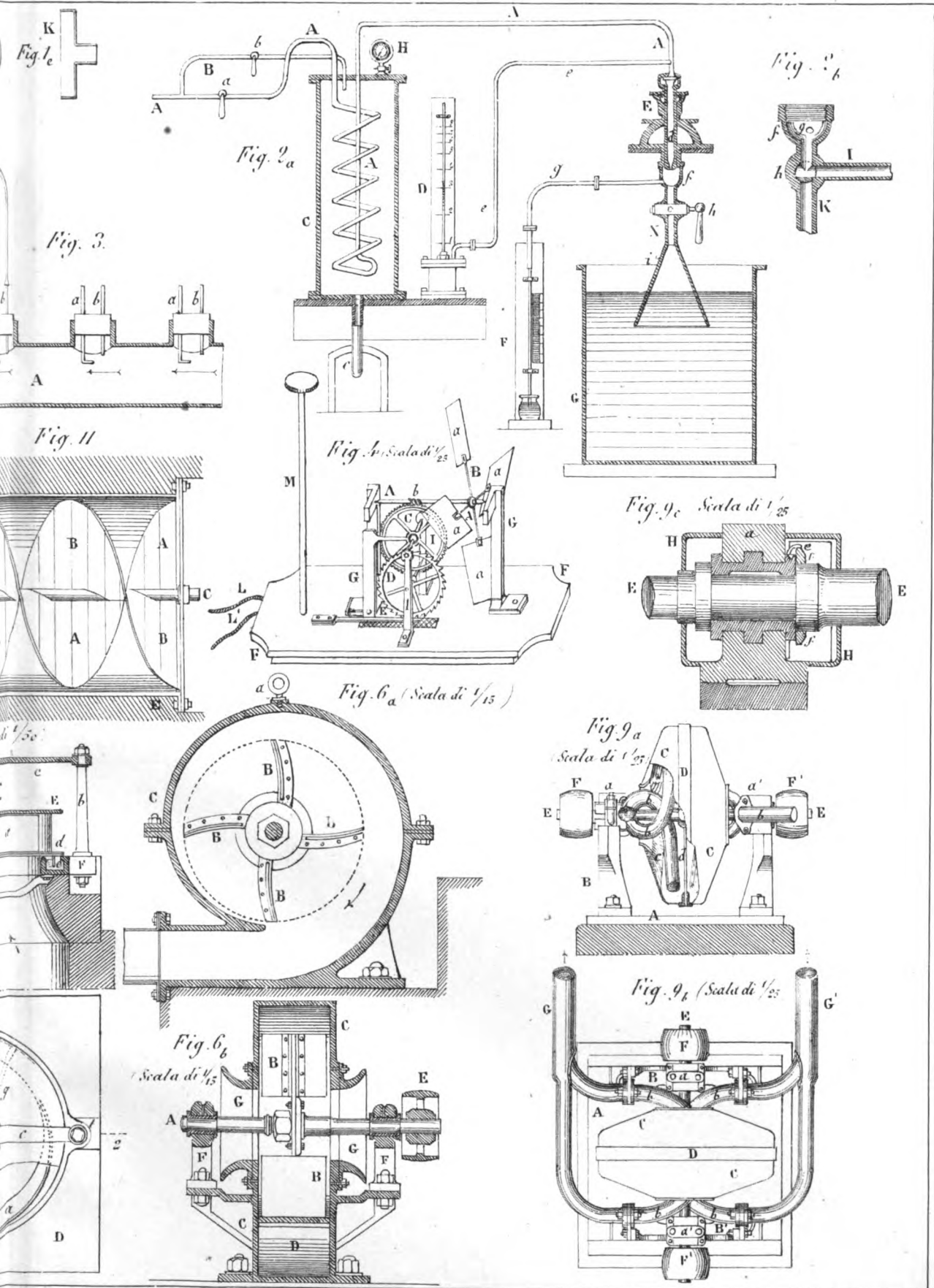

Fig. 6.







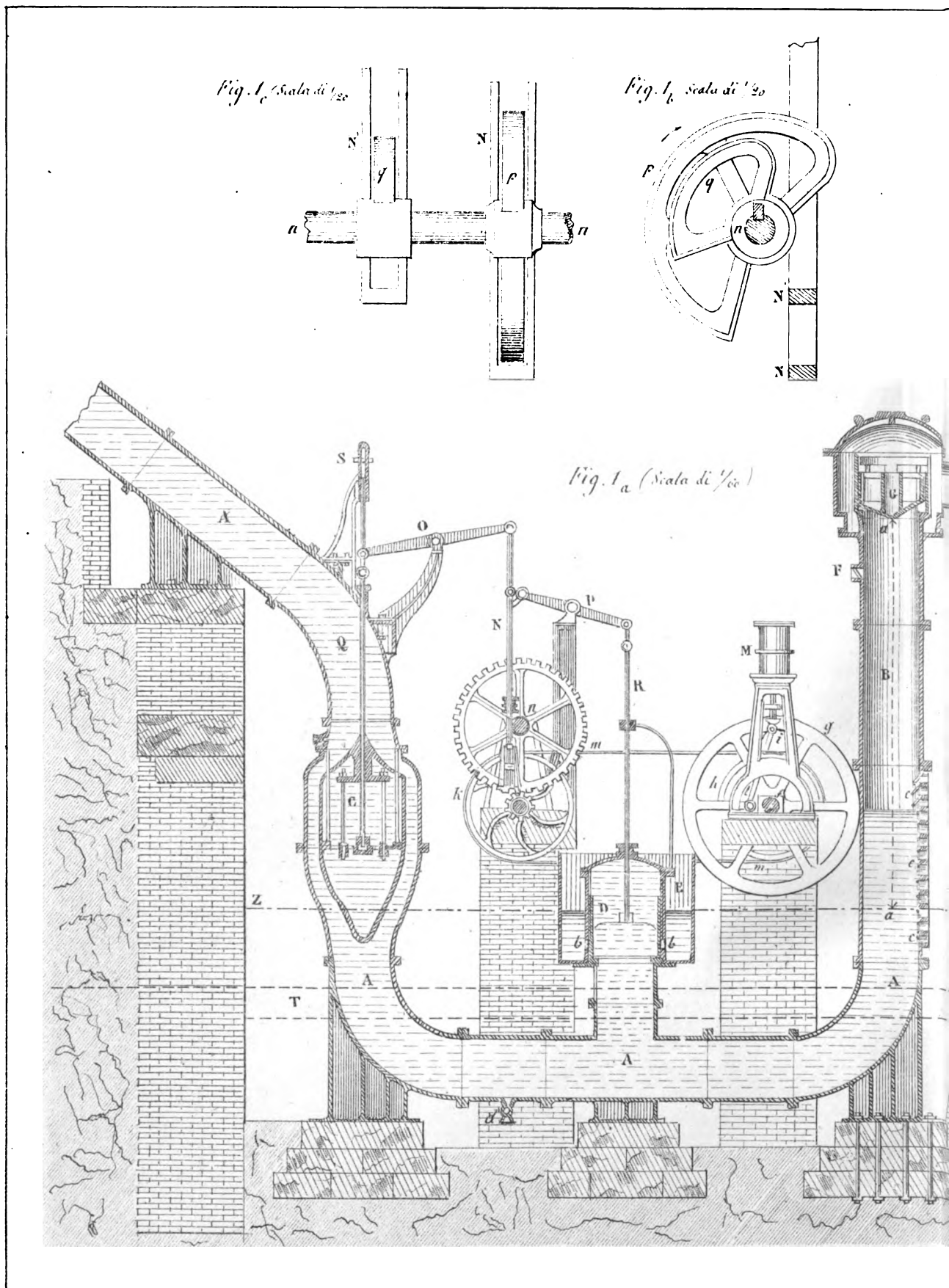
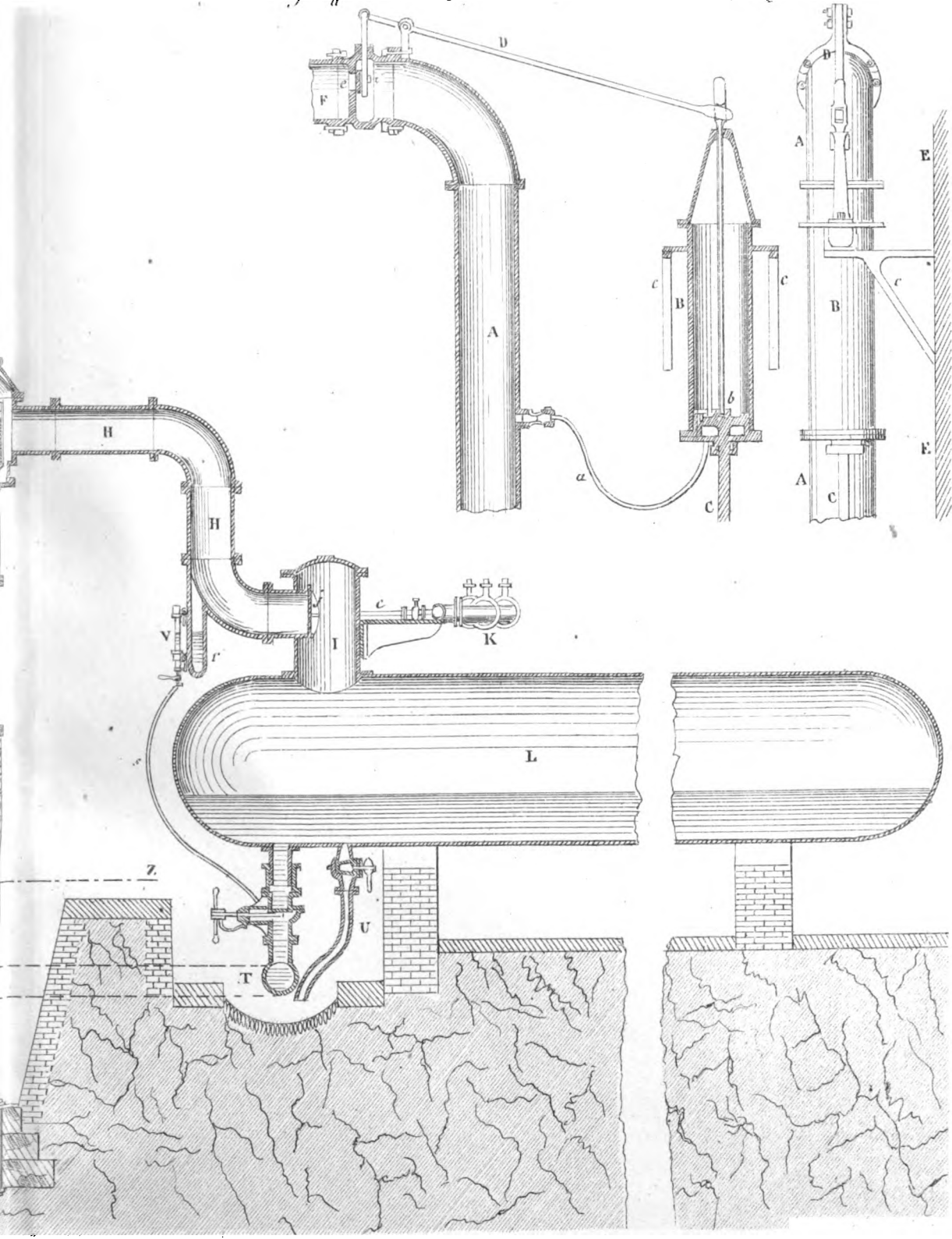
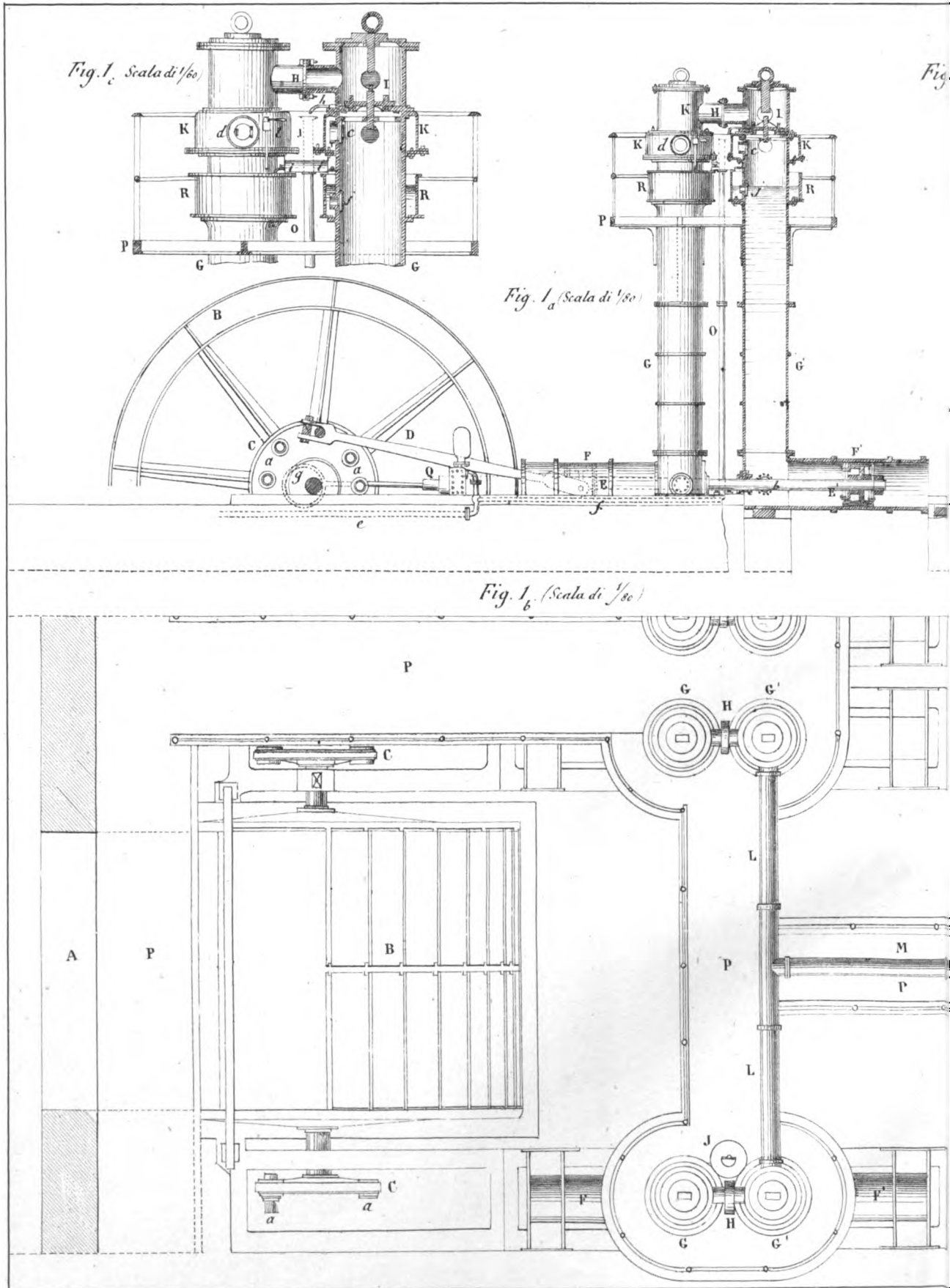
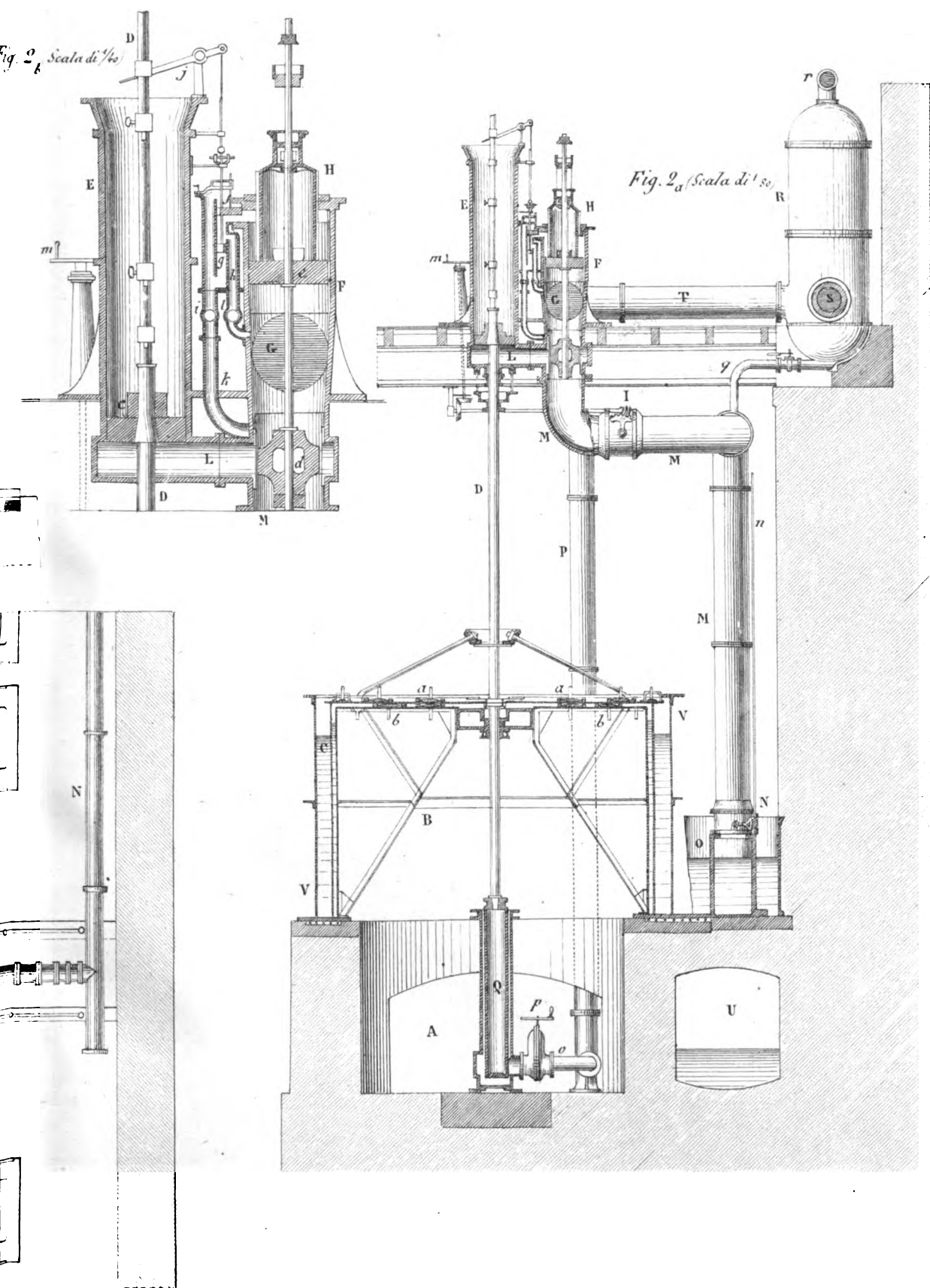

Fig. 2_a Scala di 1/25

Fig. 2_b Scala di 1/25







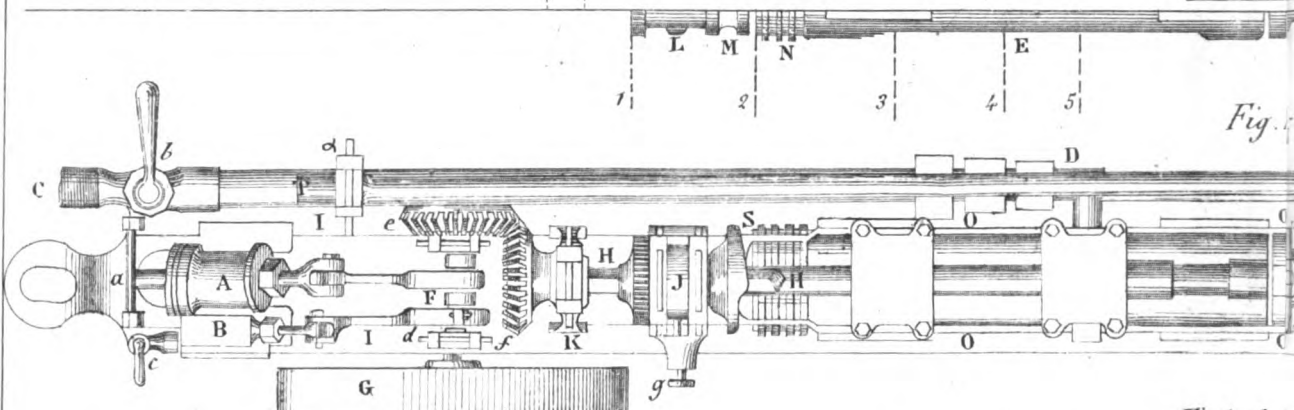
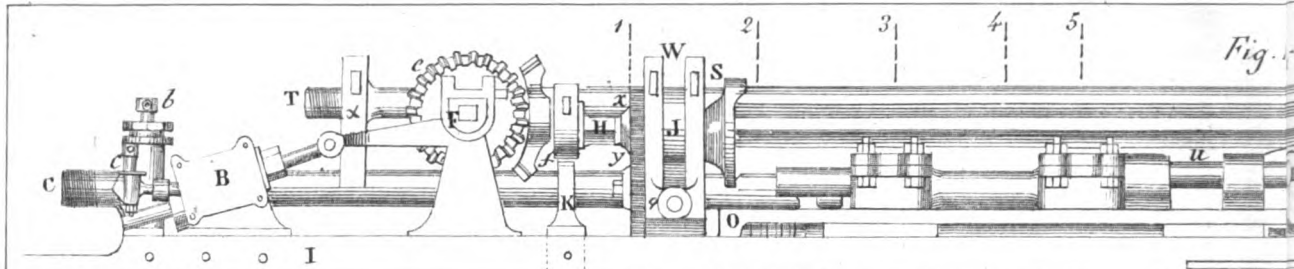

Fig. 1_c - Scala di 1/6

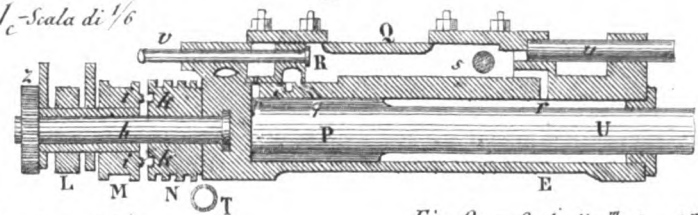

Fig. 1_d - Scala di 1/6

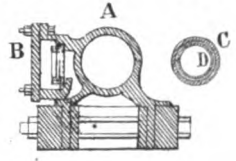

Fig. 1_f - Scala di 1/6

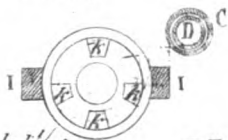

Fig. 2_g - Scala di 0,06 per 1.^m

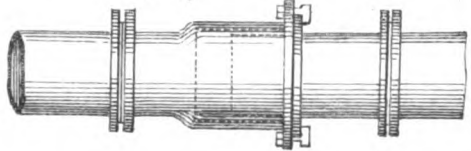

Fig. 1_g - Scala di 1/6

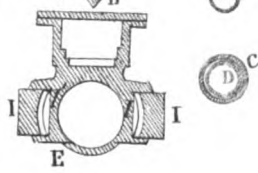

Fig. 2_c - Scala di 0,06 per 1.^m

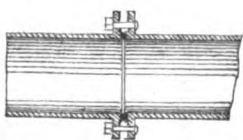

Fig. 2_a - Scala di 0,06 per 1.^m

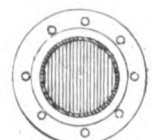

Fig. 1_i - Scala di 1/6

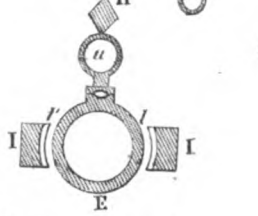

Fig. 2_e - Scala di 0,06 per 1.^m



Fig. 2_f - Scala di 0,25 per 1.^m

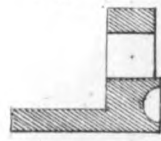

Fig. 1_g - Scala di 1/6

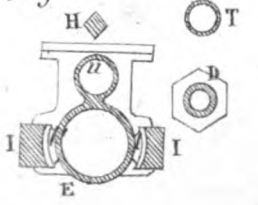

Fig. 2_i - Scala di 0,06 per 1.^m

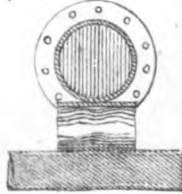
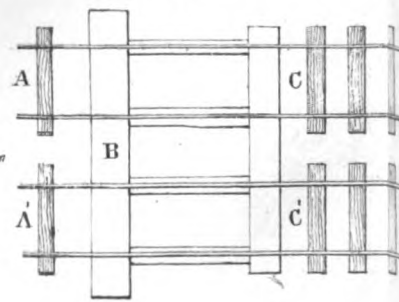
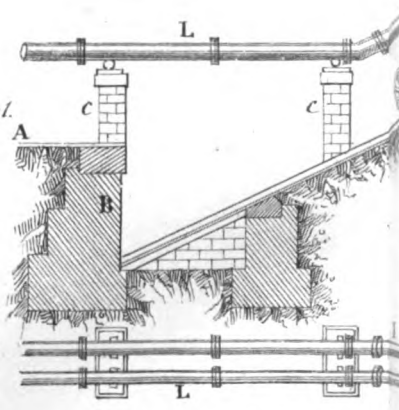
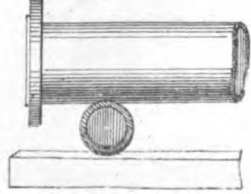

Fig. 2_h - Scala di 0,06 per 1.^m



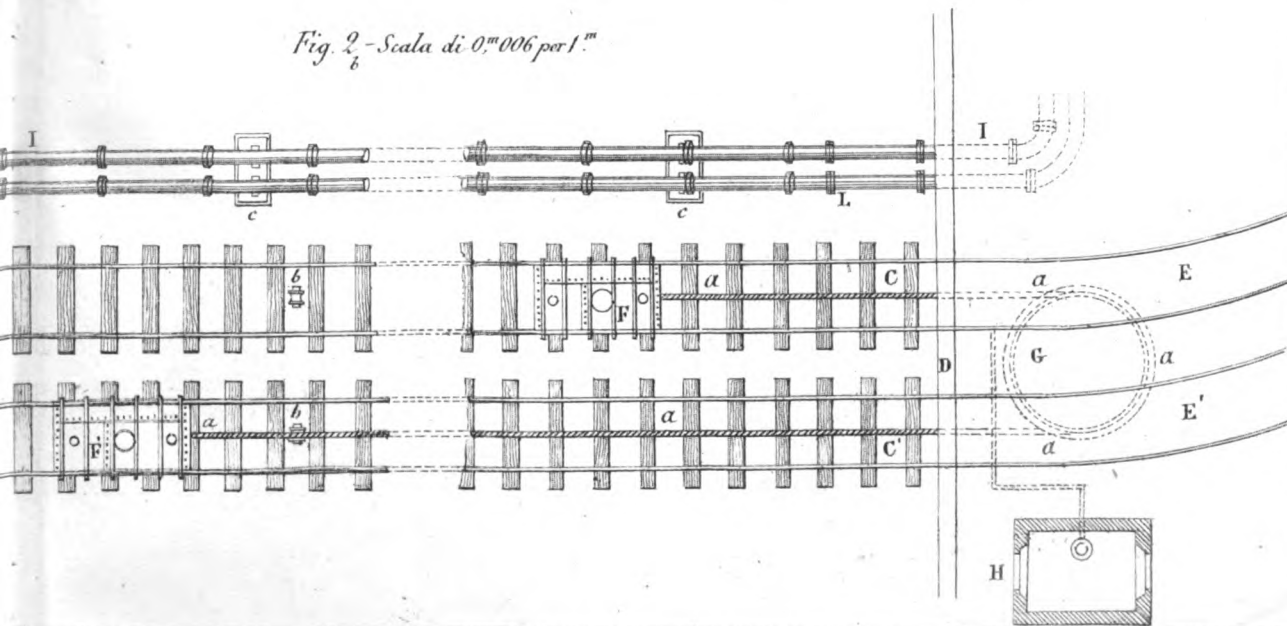
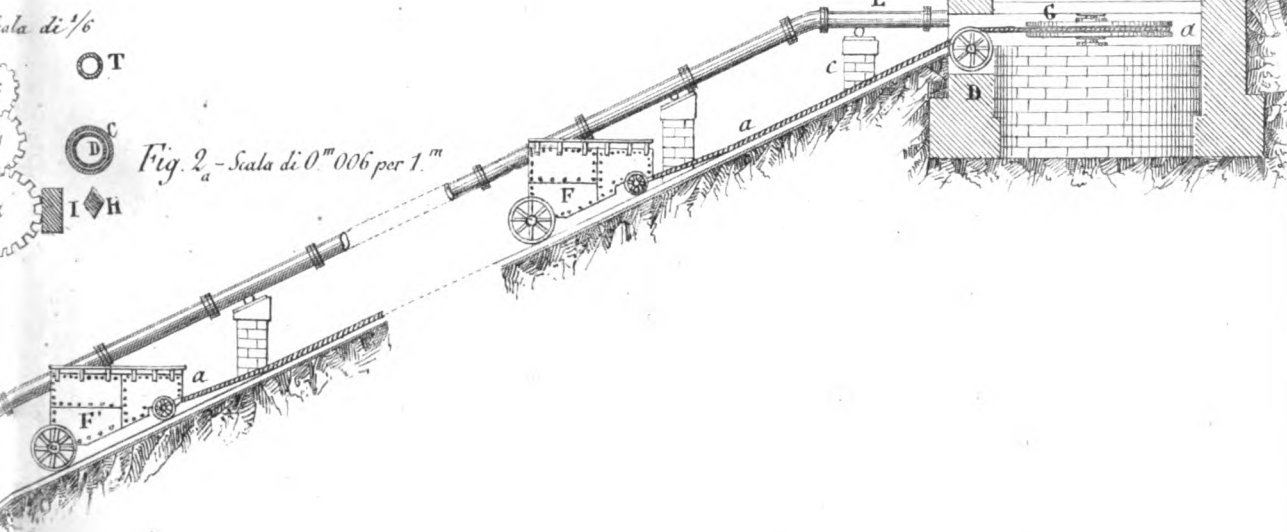
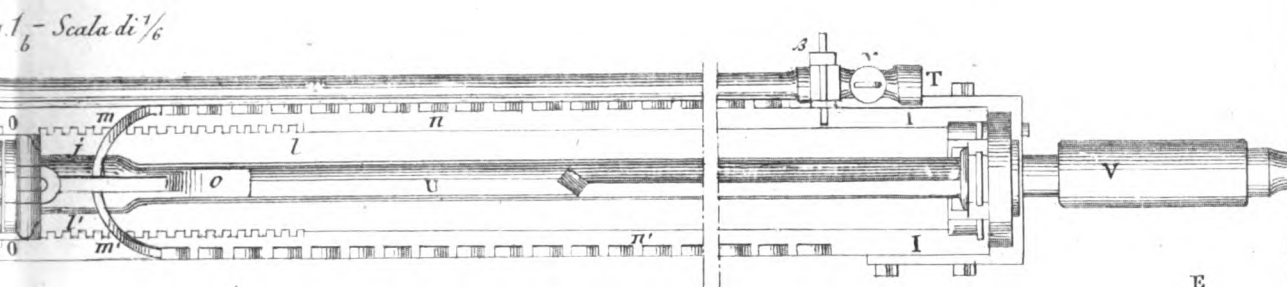
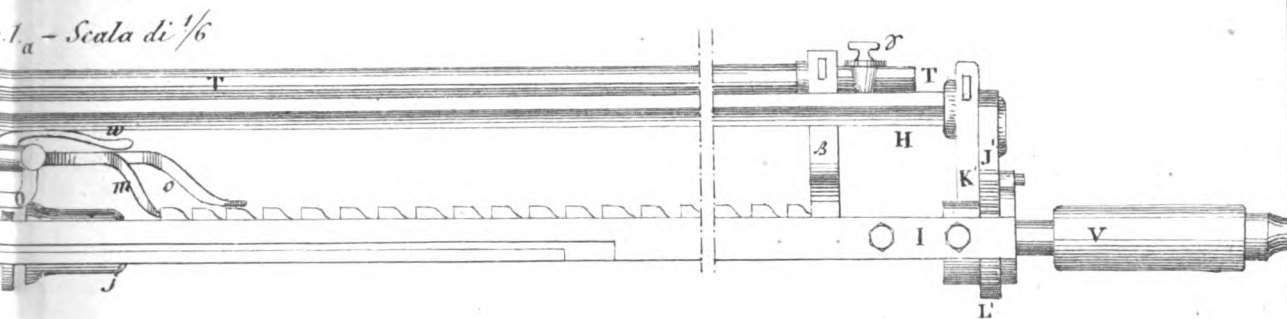
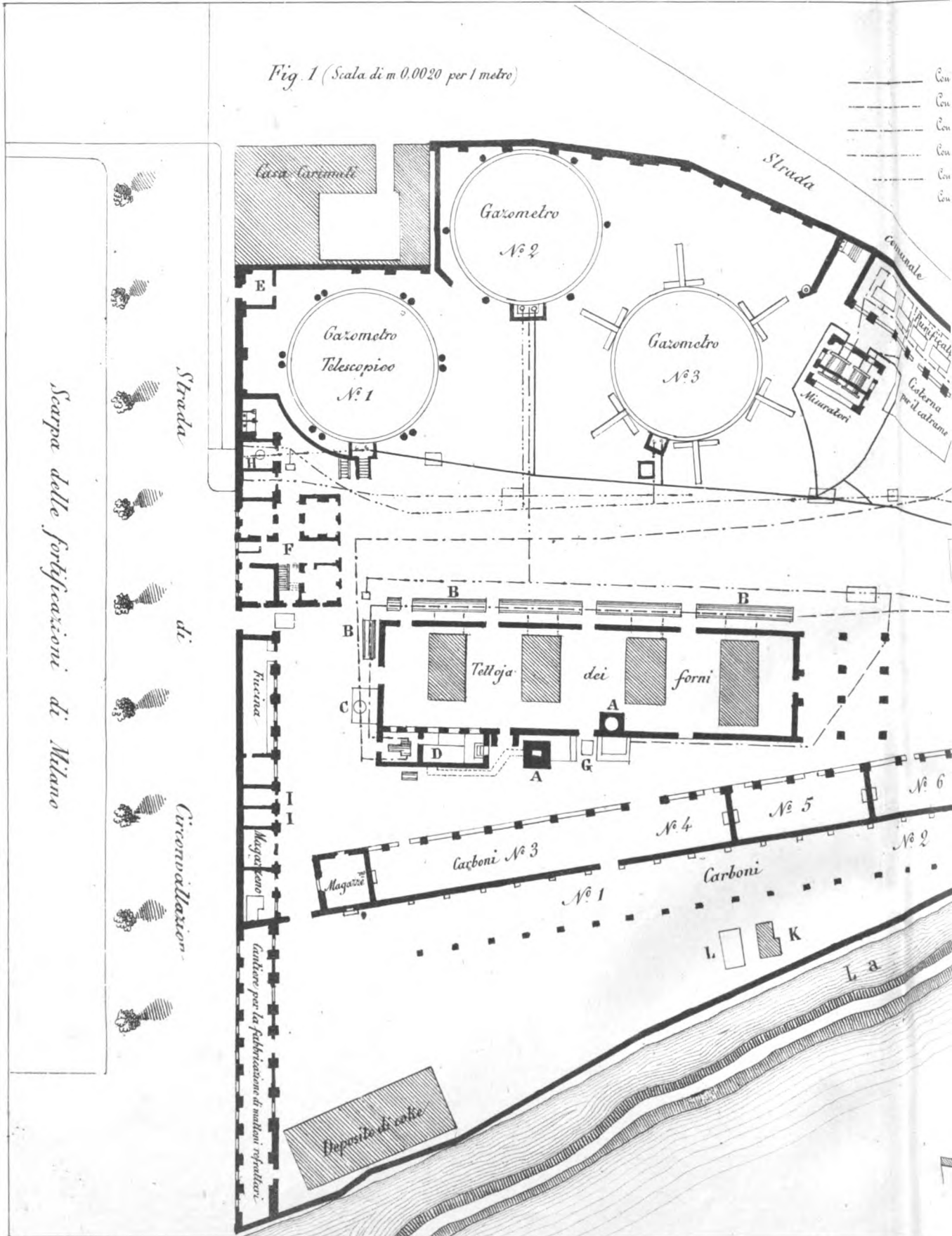

Fig. 1 (Scala di m 0,0020 per 1 metro)



Segni convenzionali

- Condotta di gaz degli apparecchi misuralori ai gazonetti
- - - - - Condotte di calcame
- · - · - Condotta di gaz delle storte al condensatore ed al estrattore
- · - · - Condotta di gaz dall'estrattore ai purificatori e misuralori
- · - · - Condotta di gaz a valle dei gazonetti
- - - - - Condotte d'acqua

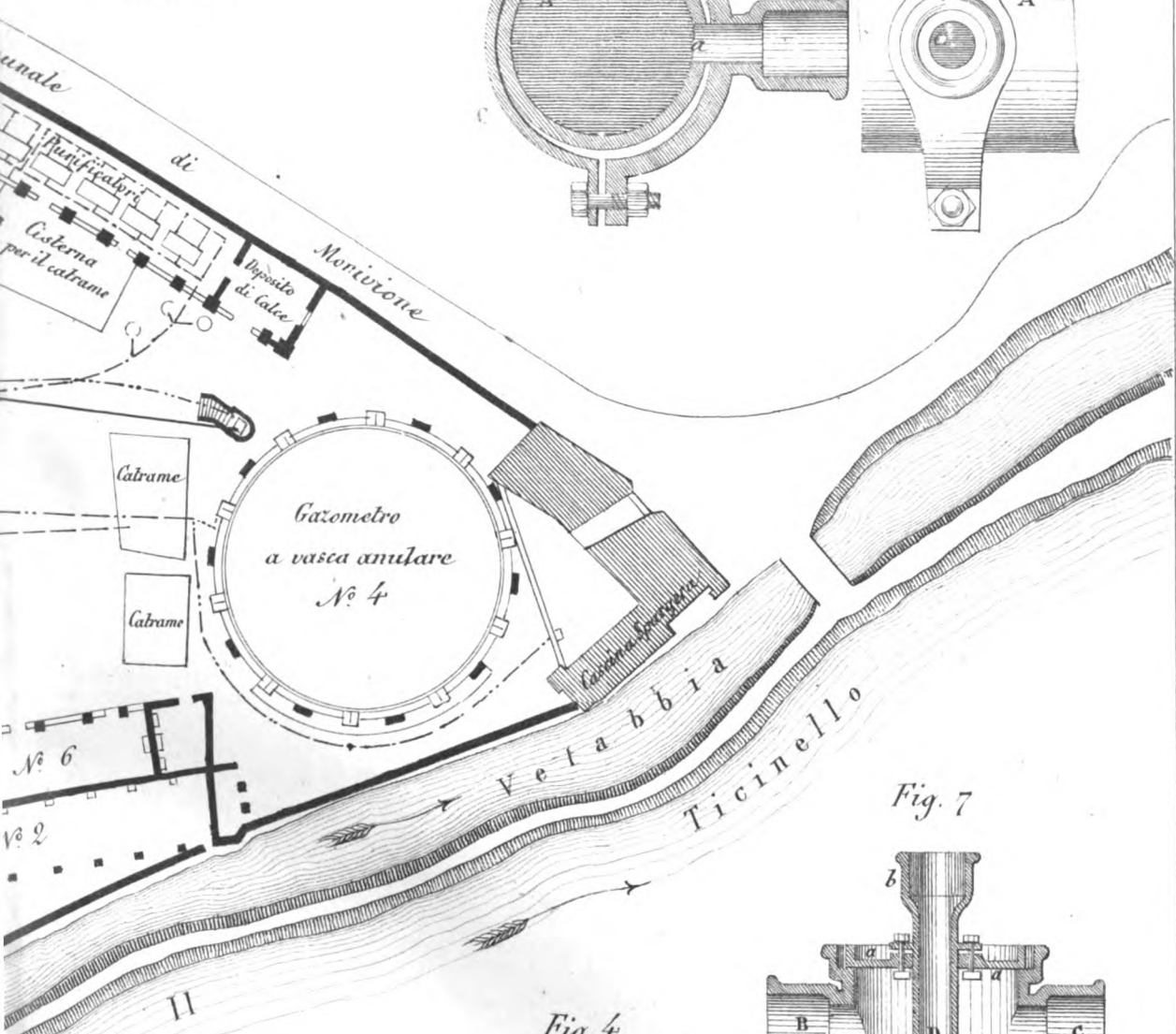

Fig. 6_a

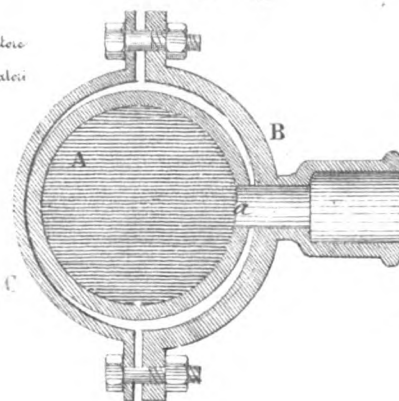

Fig. 6_b

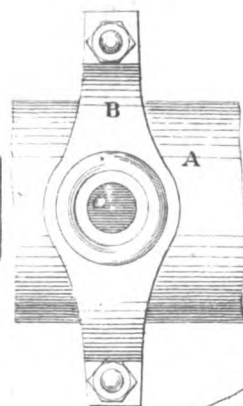

Fig. 7

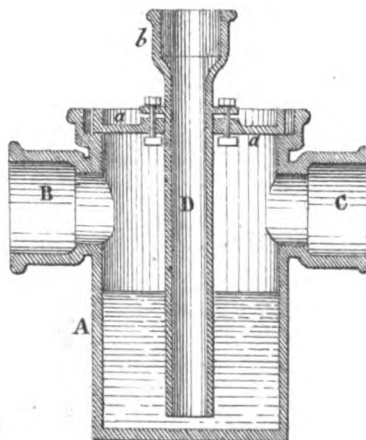

Fig. 4.



Fig. 5



Fig. 2.

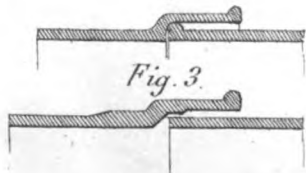
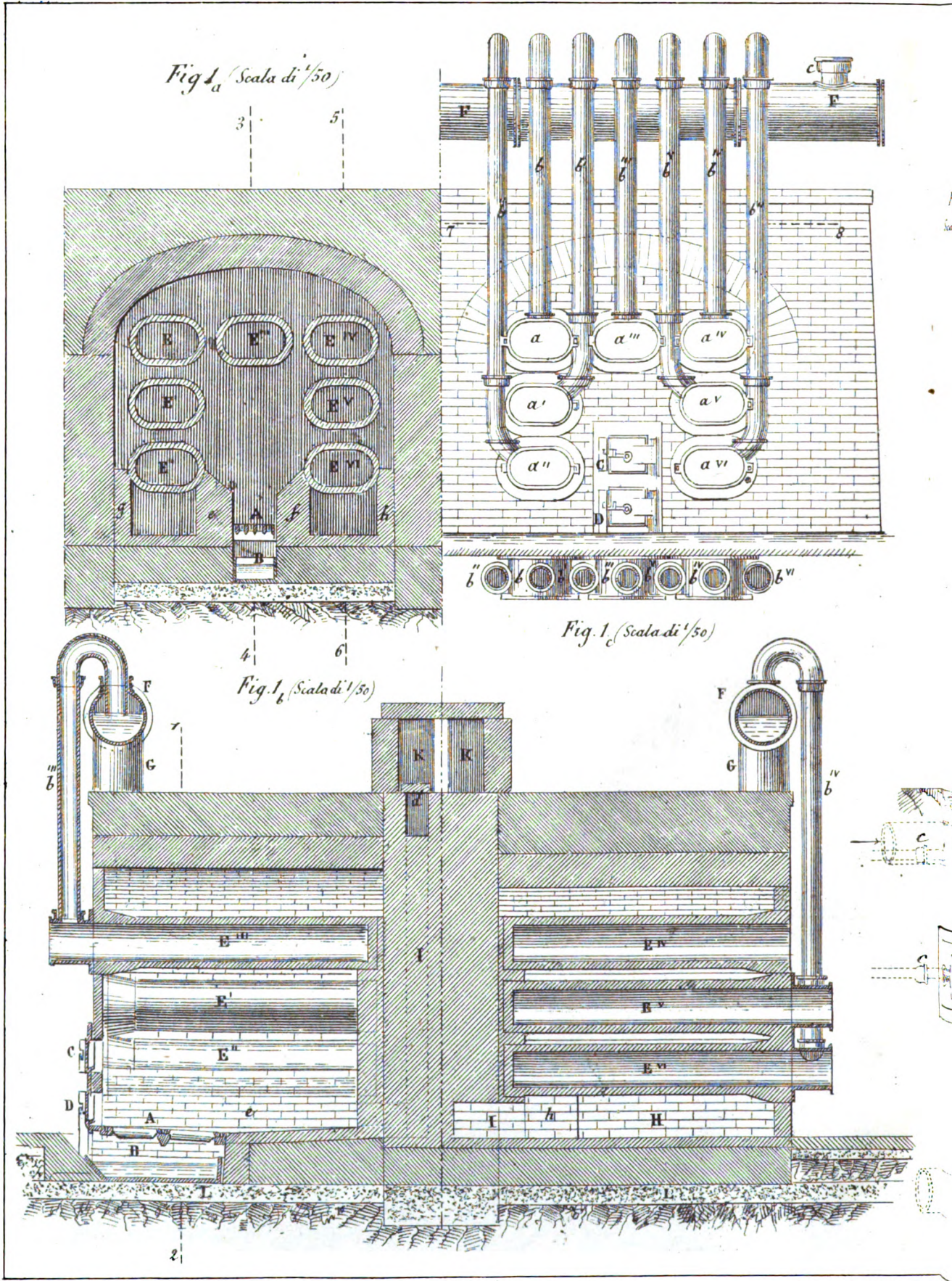
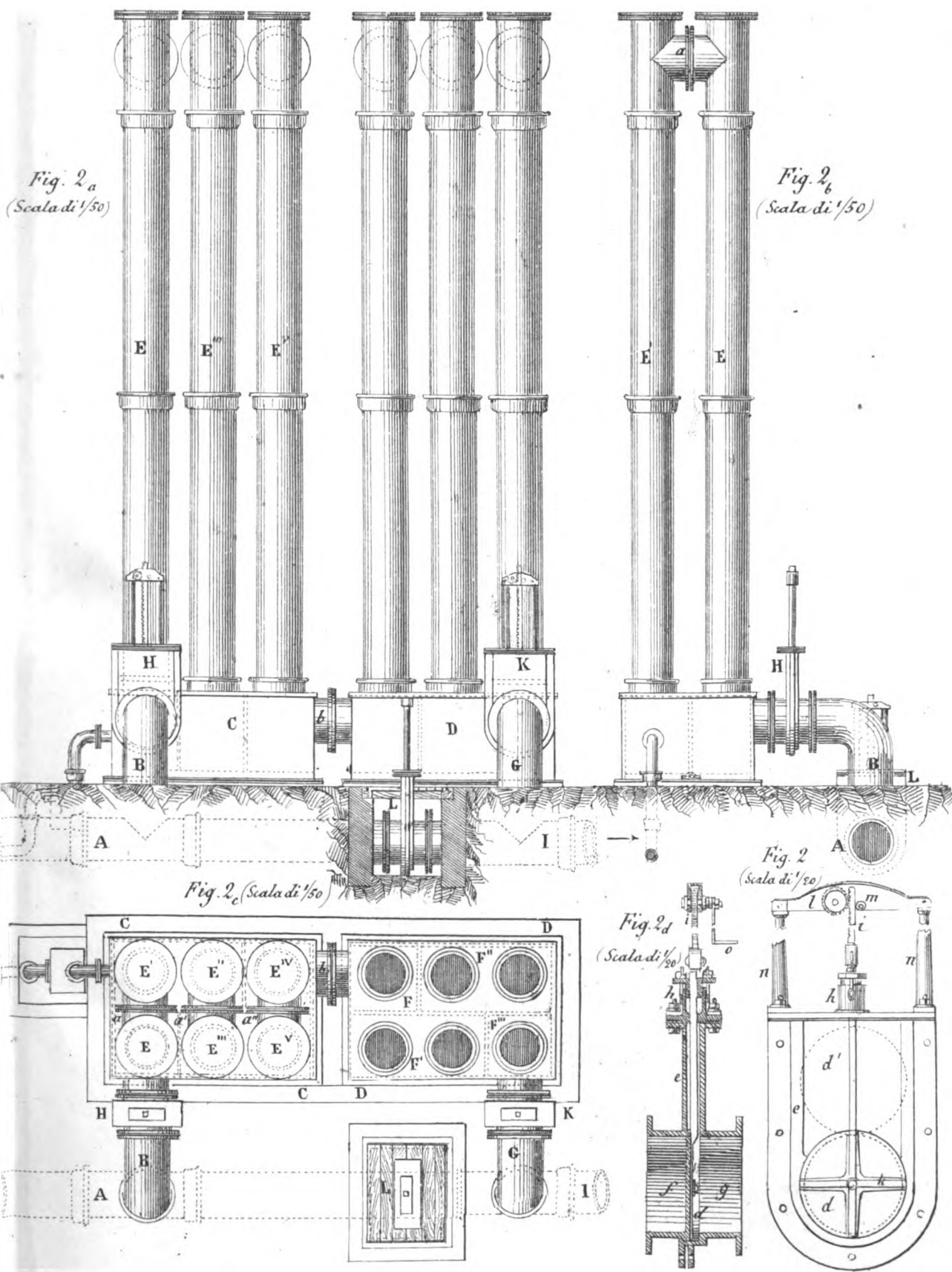
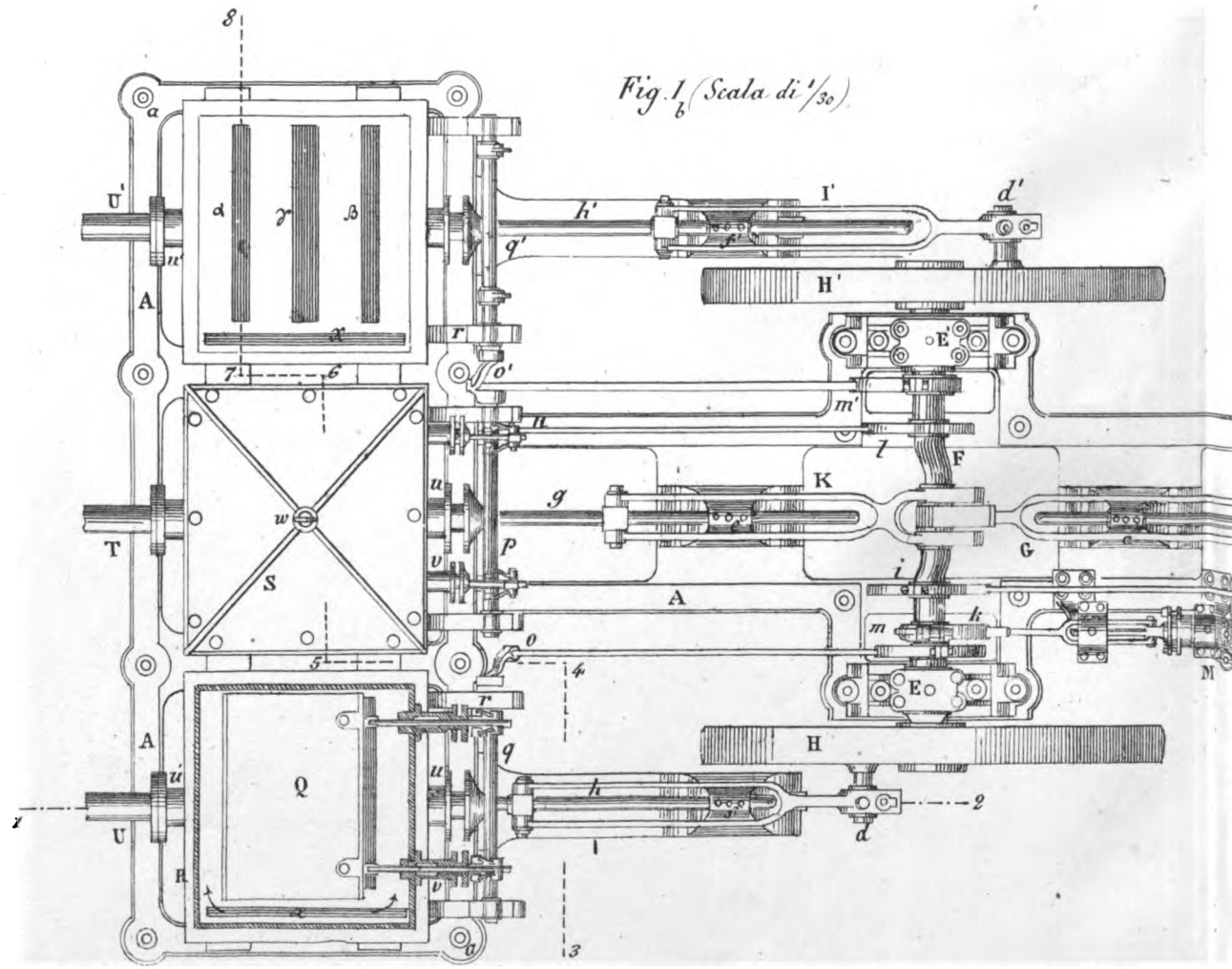
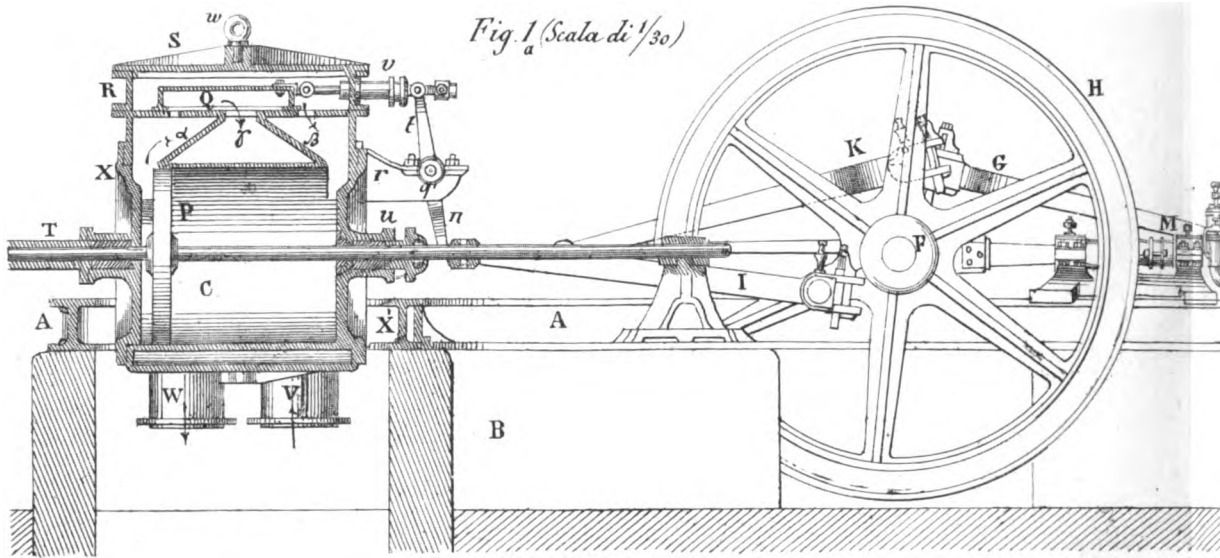

Fig. 3.









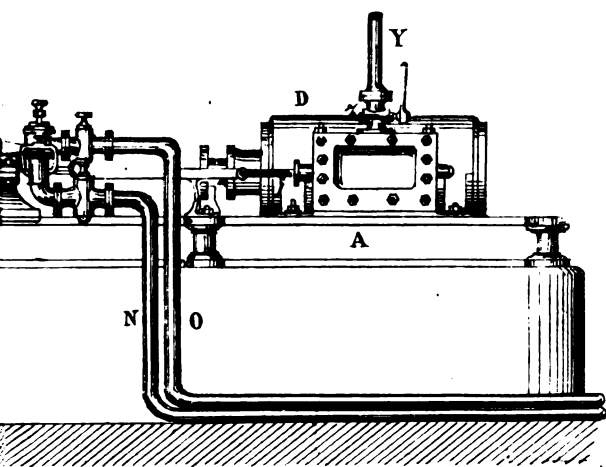

Fig. 1 (Scala di 1/30)

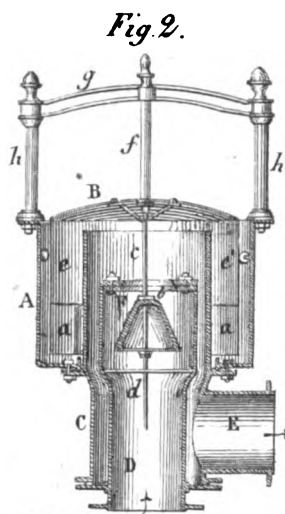

Fig. 2.

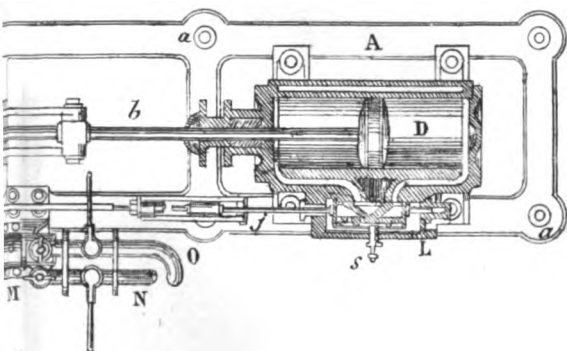
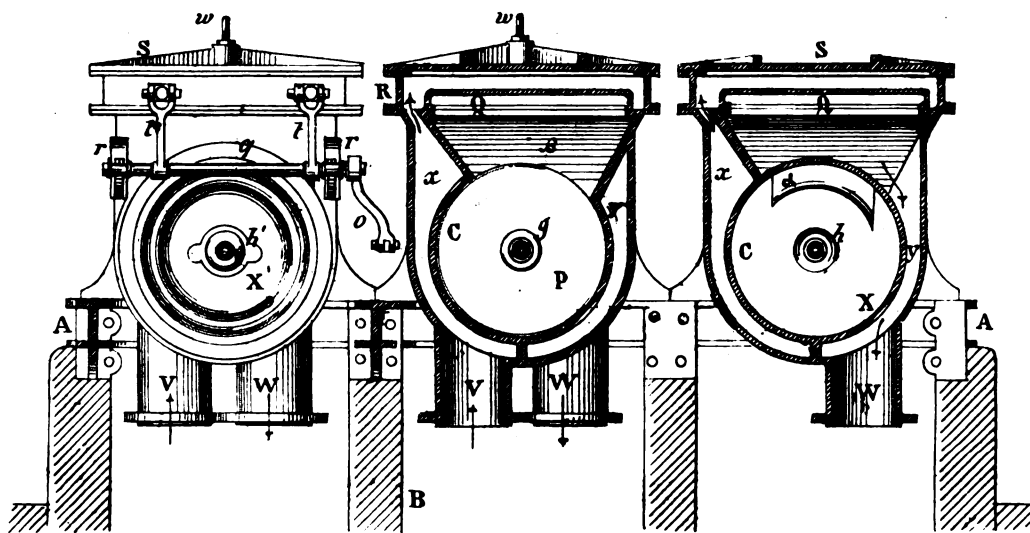
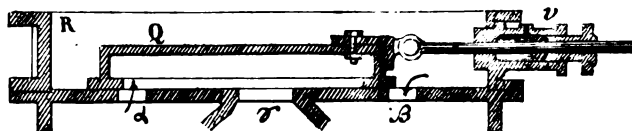

Fig. 1d (Scala di 1/15)



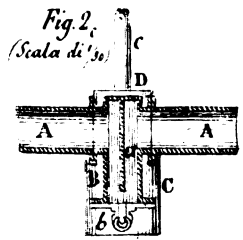
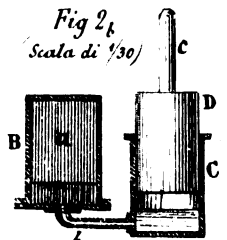
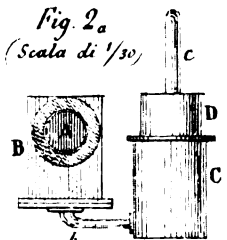
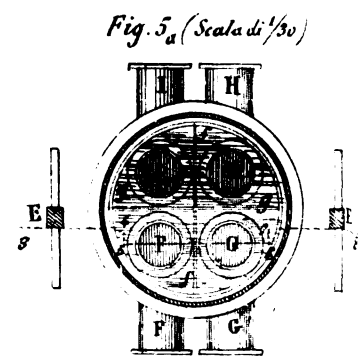
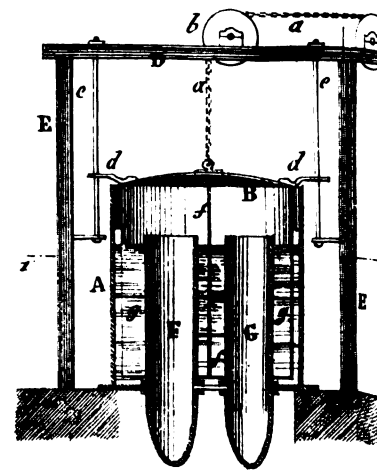
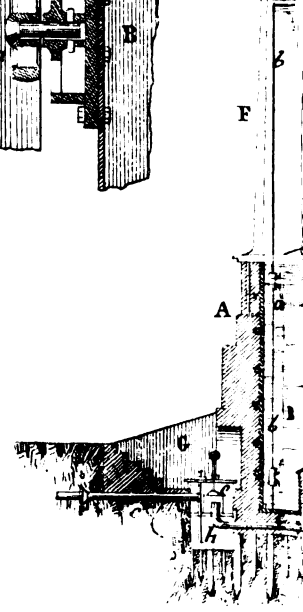
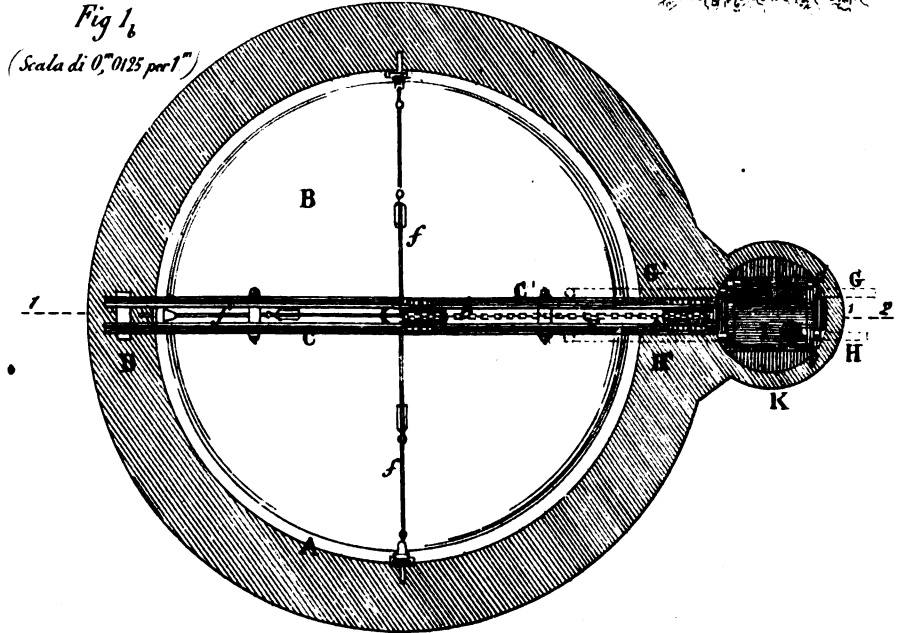
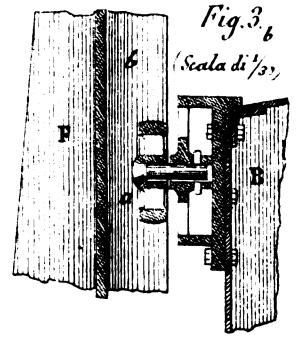
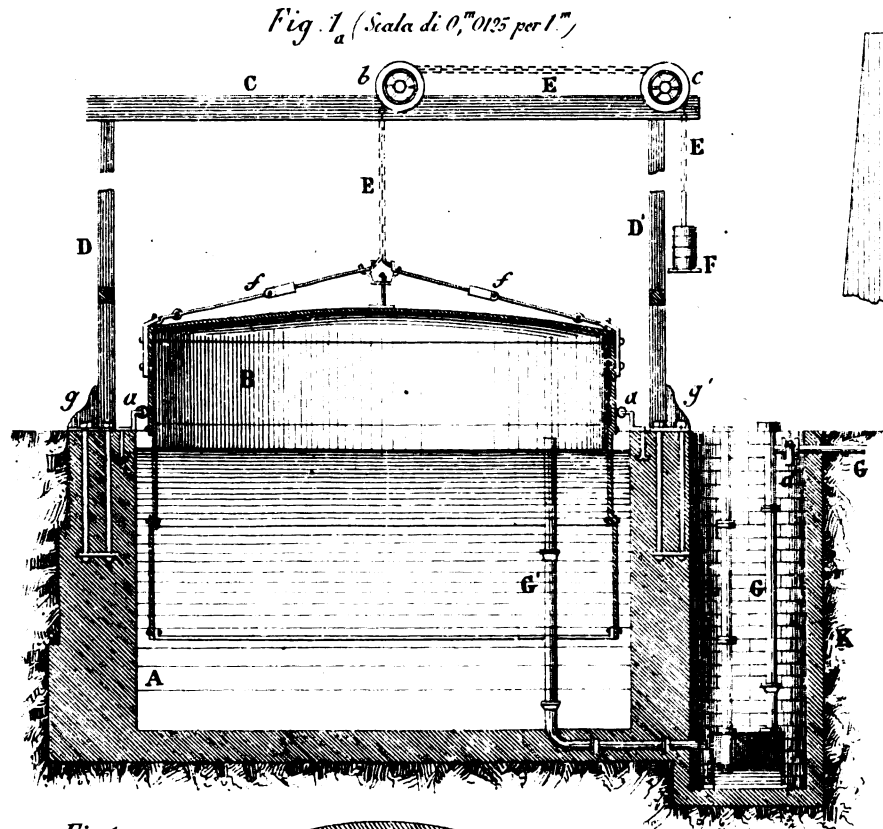

Fig. 3_a (Scala di 1/200)

Fig. 3_c
(Scala di 1/30)

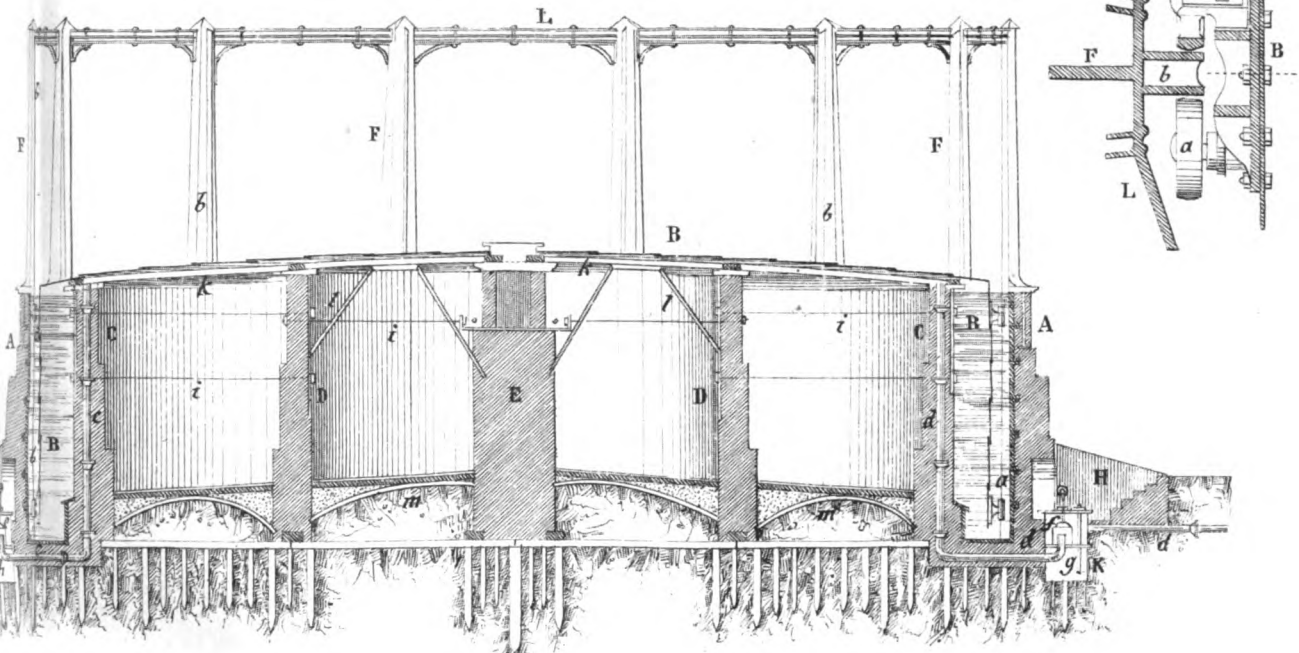
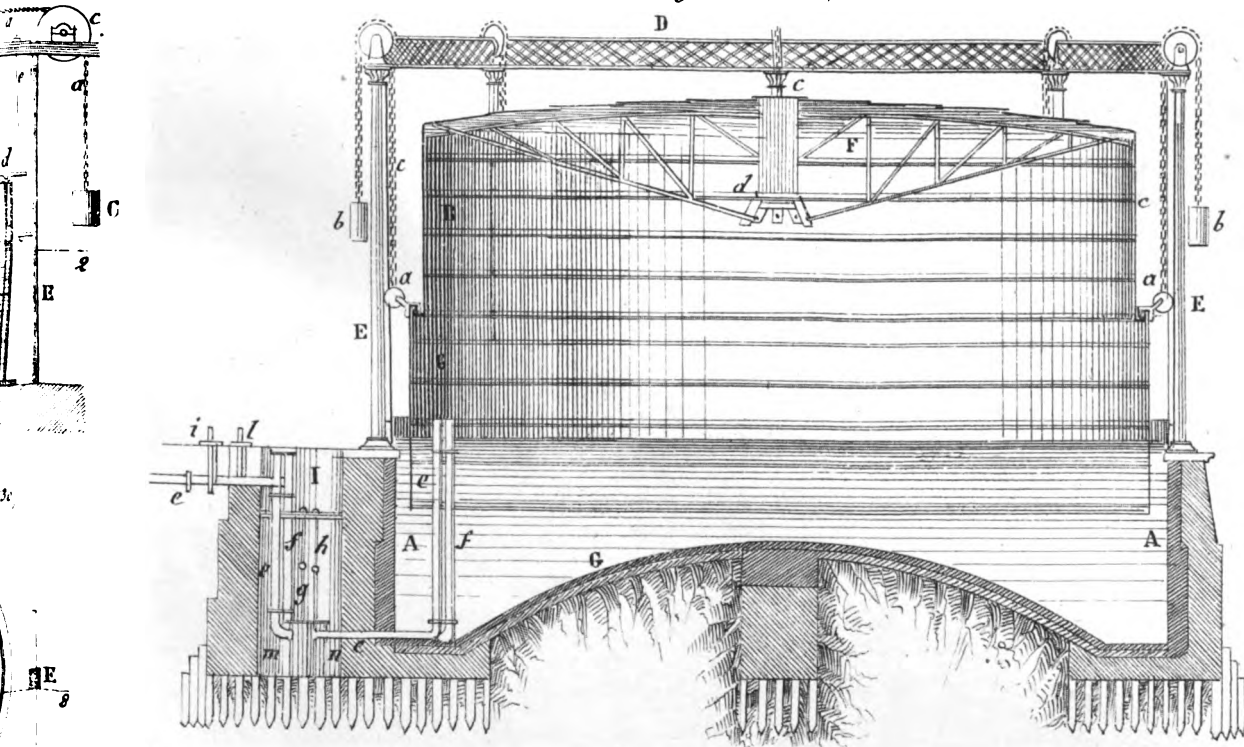

Fig. 4 (Scala di 1/200)



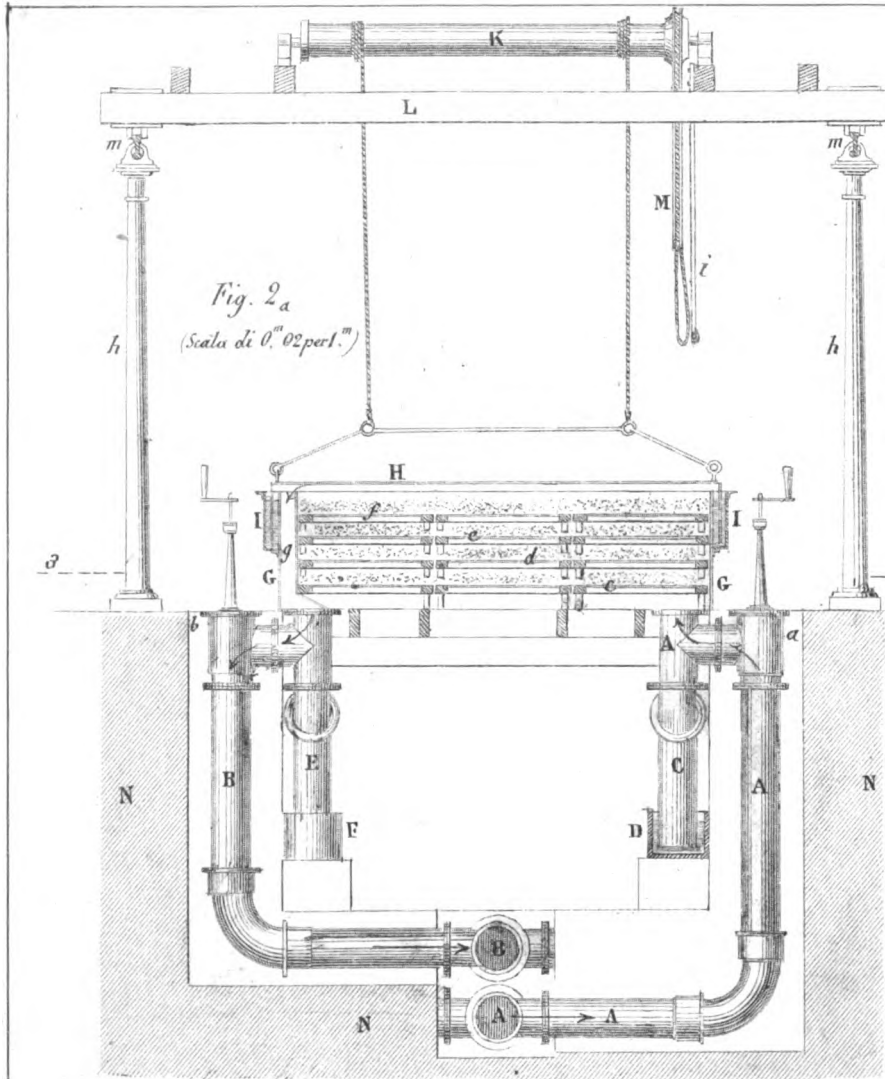

Fig. 2a
(Scala di 0.^m02 per 1.^m)

Fig. 4a
(Scala di 1/5)

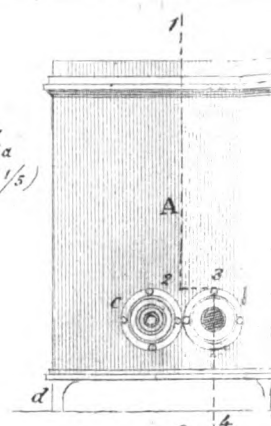

Fig. 3
(Scala di 0.^m004 per 1.^m)

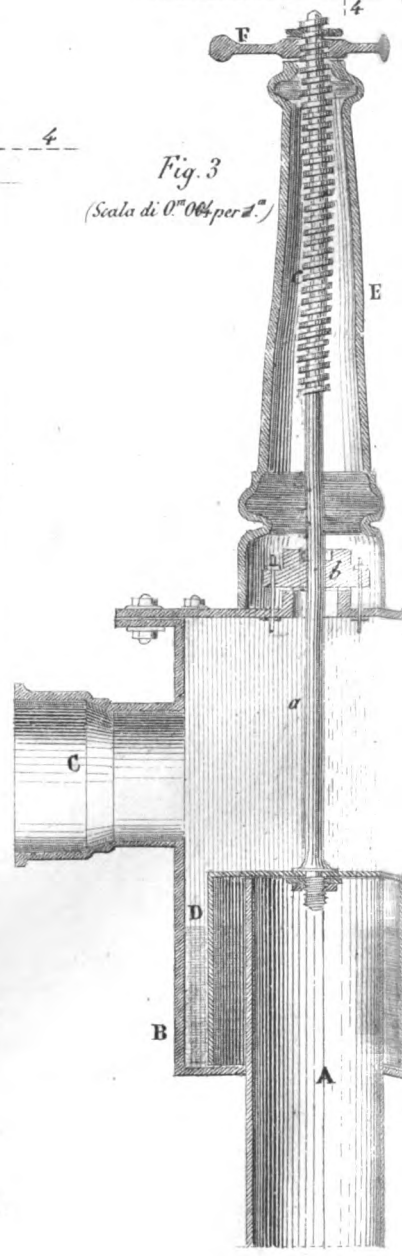
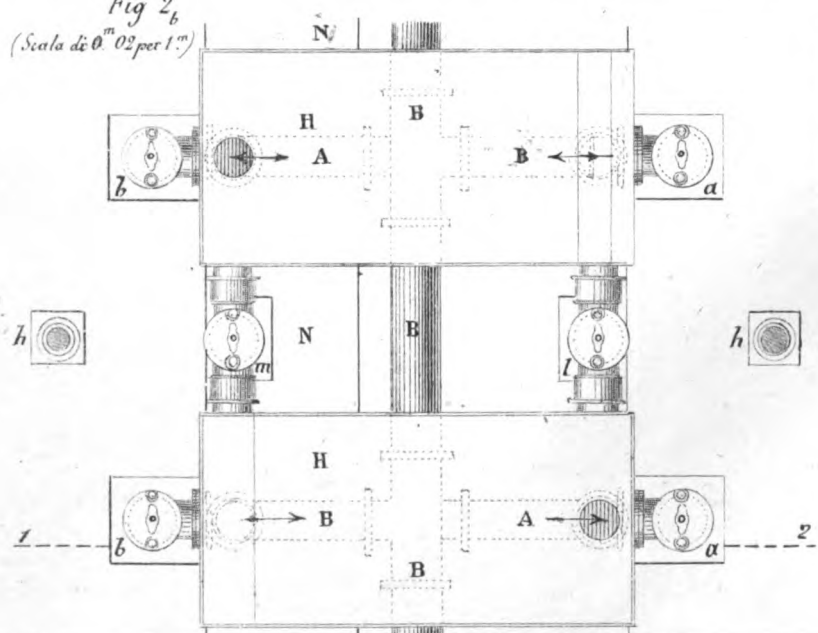
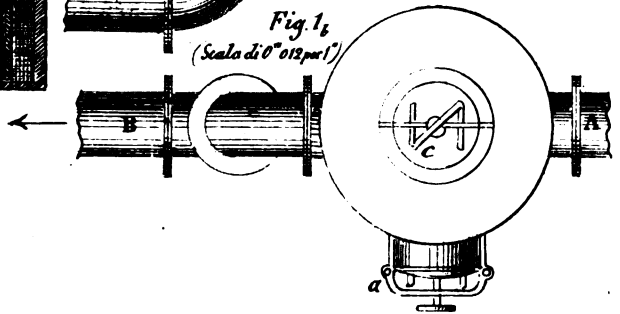
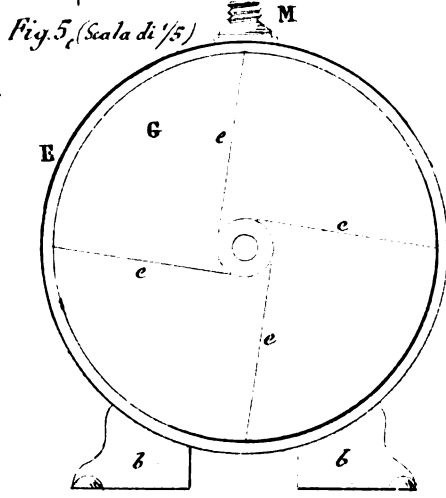
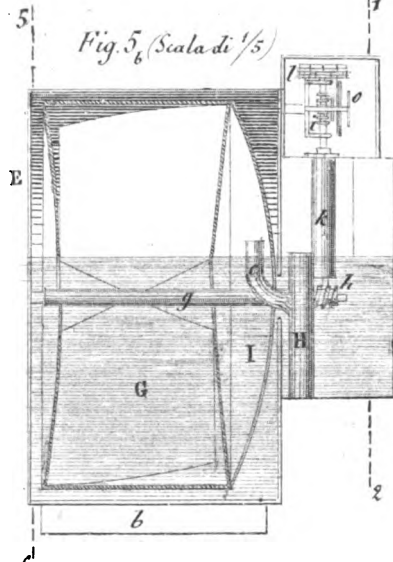
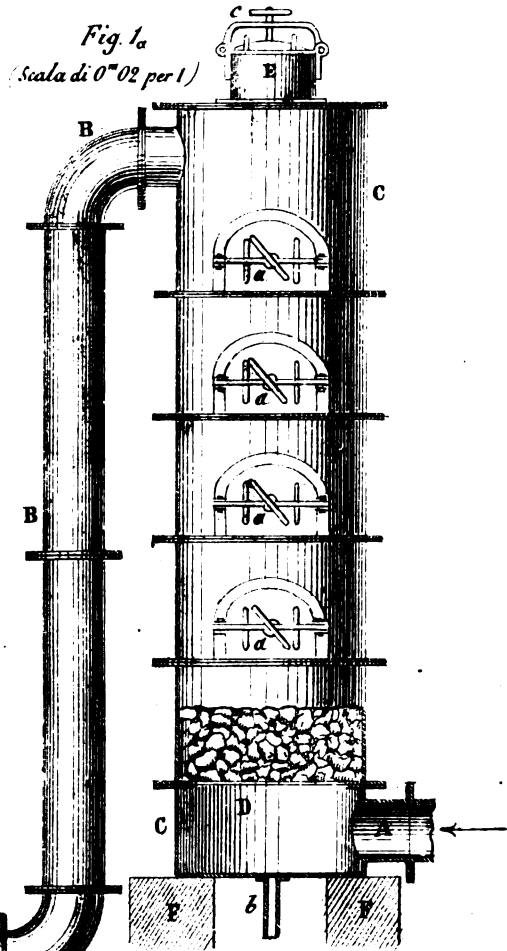
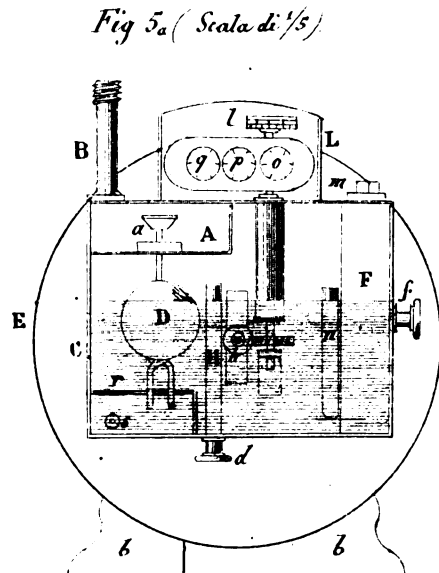
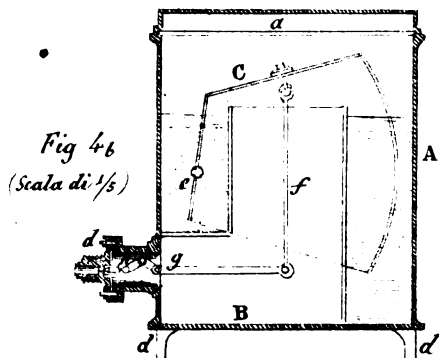

Fig. 2b
(Scala di 0.^m02 per 1.^m)



G. B. Maffrotti dis.

Torino Lit. P. Briola via S. Francesco



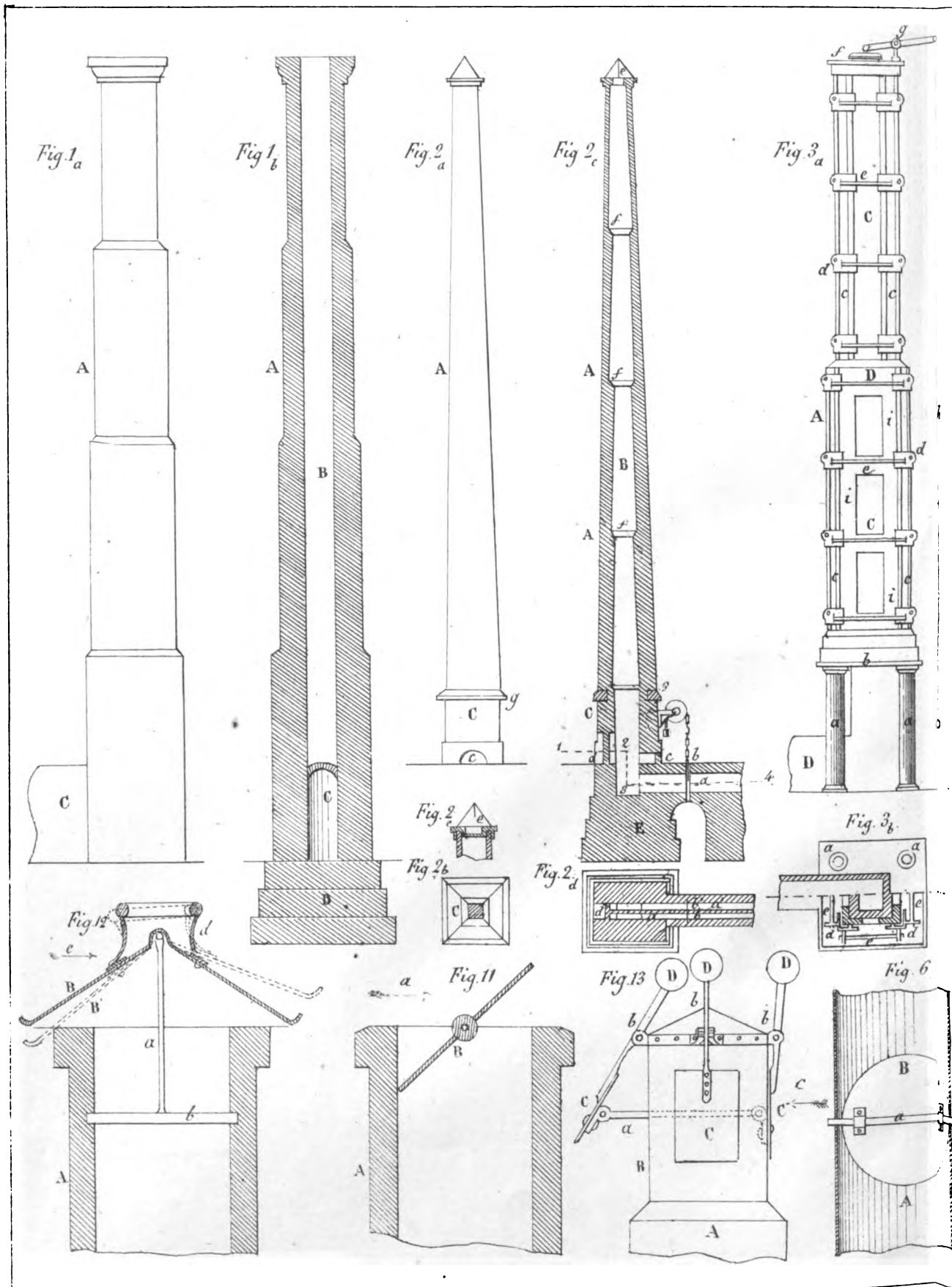

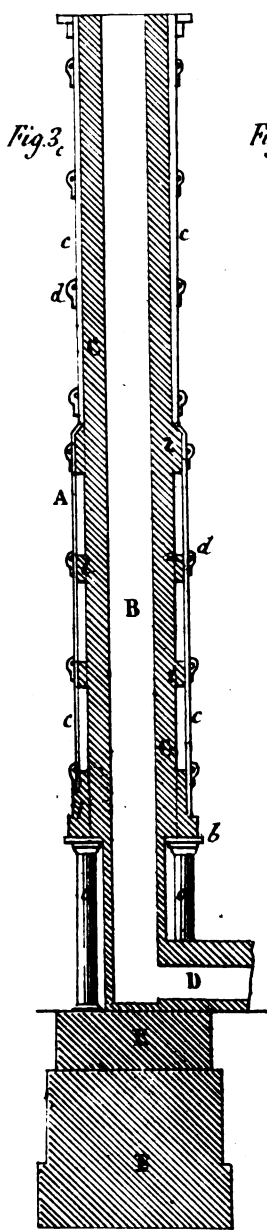

Fig. 3.

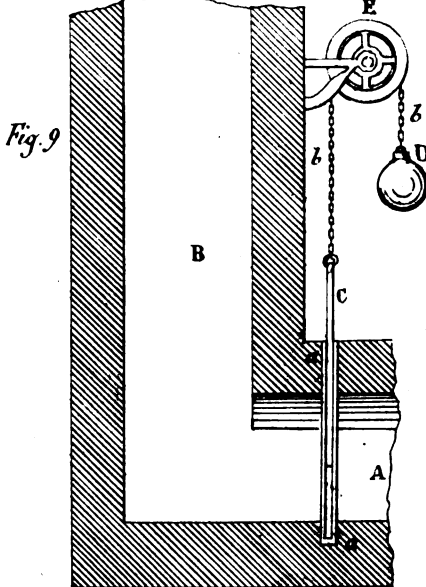

Fig. 9.

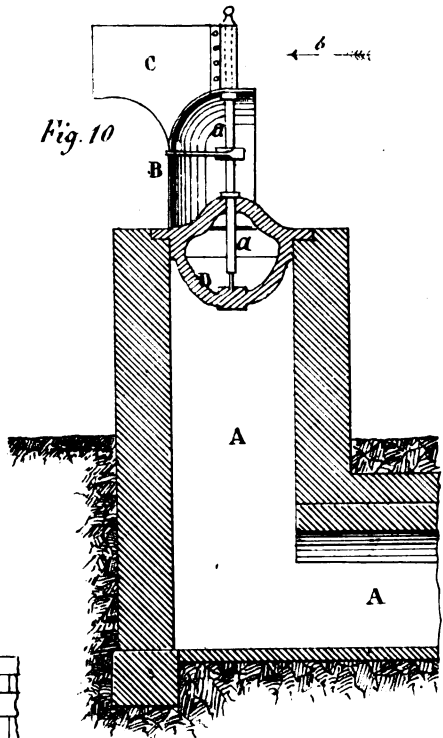

Fig. 10.

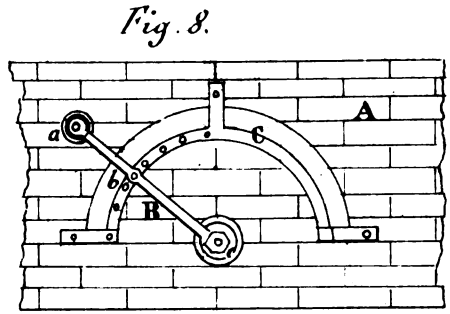

Fig. 8.

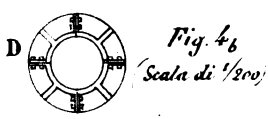

Fig. 4b
(Scala di 1/200)

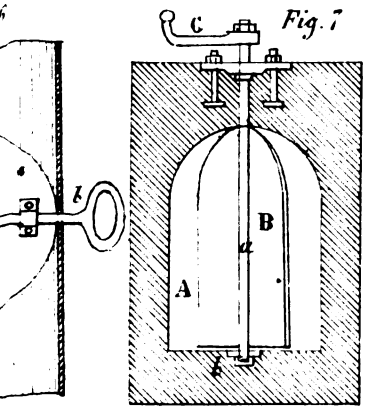

Fig. 7.

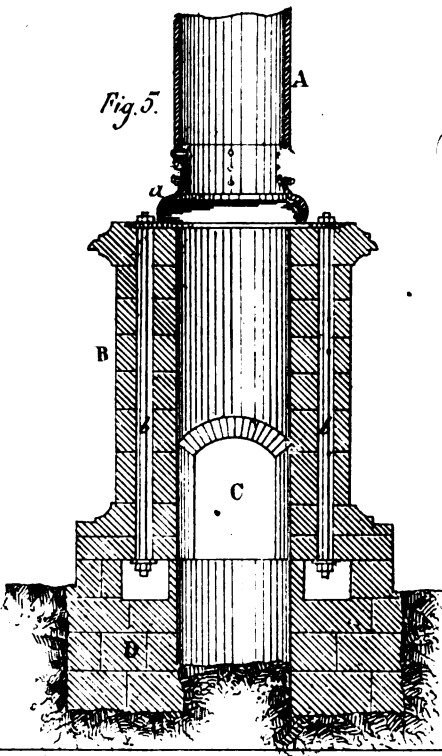

Fig. 5.

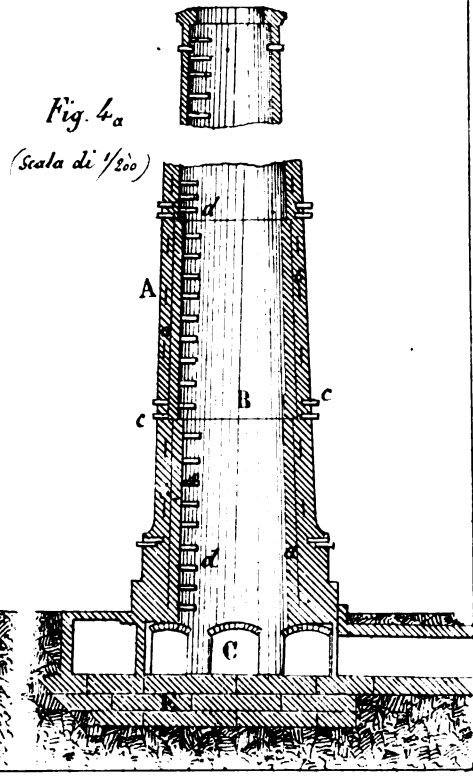
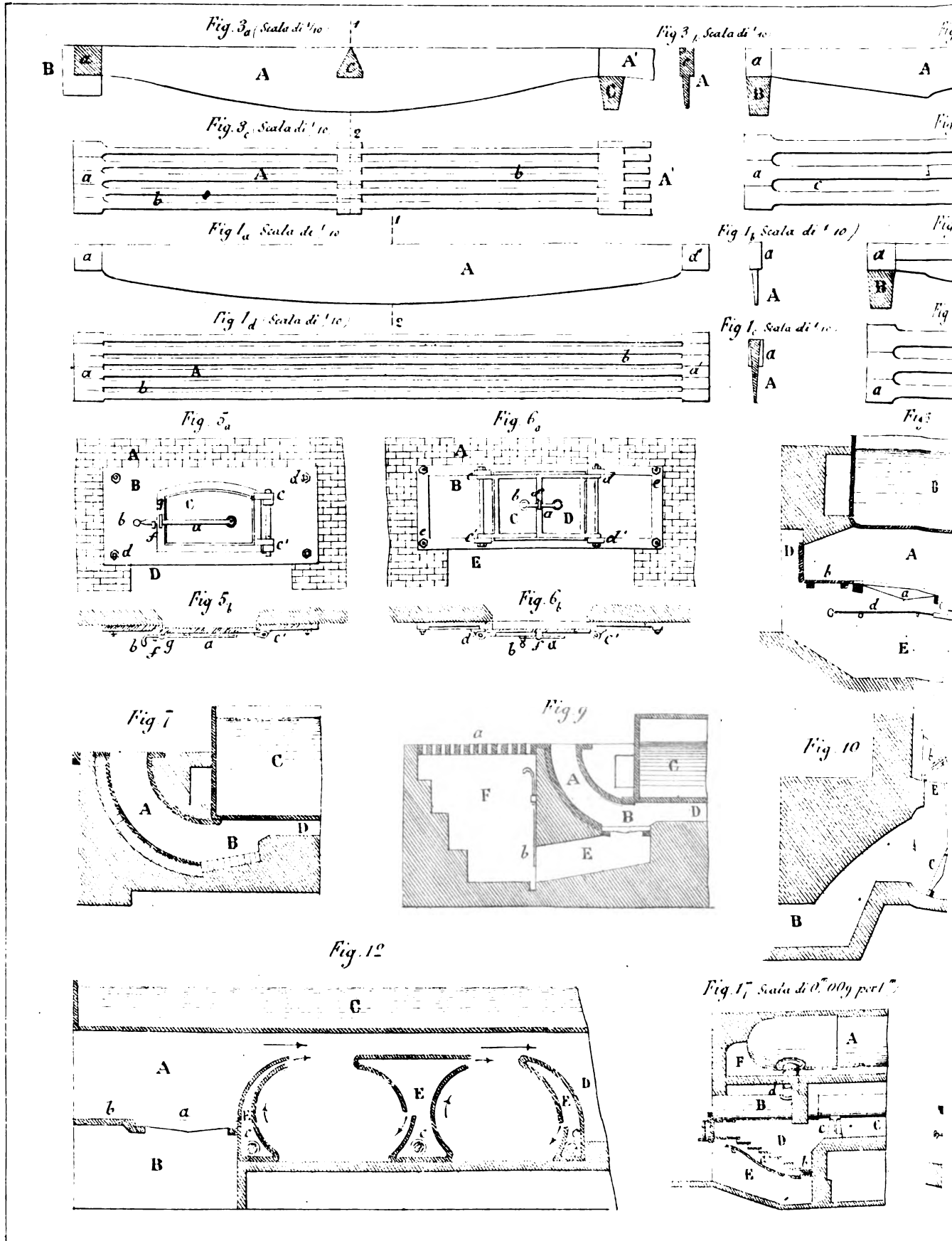

Fig. 4a
(Scala di 1/100)



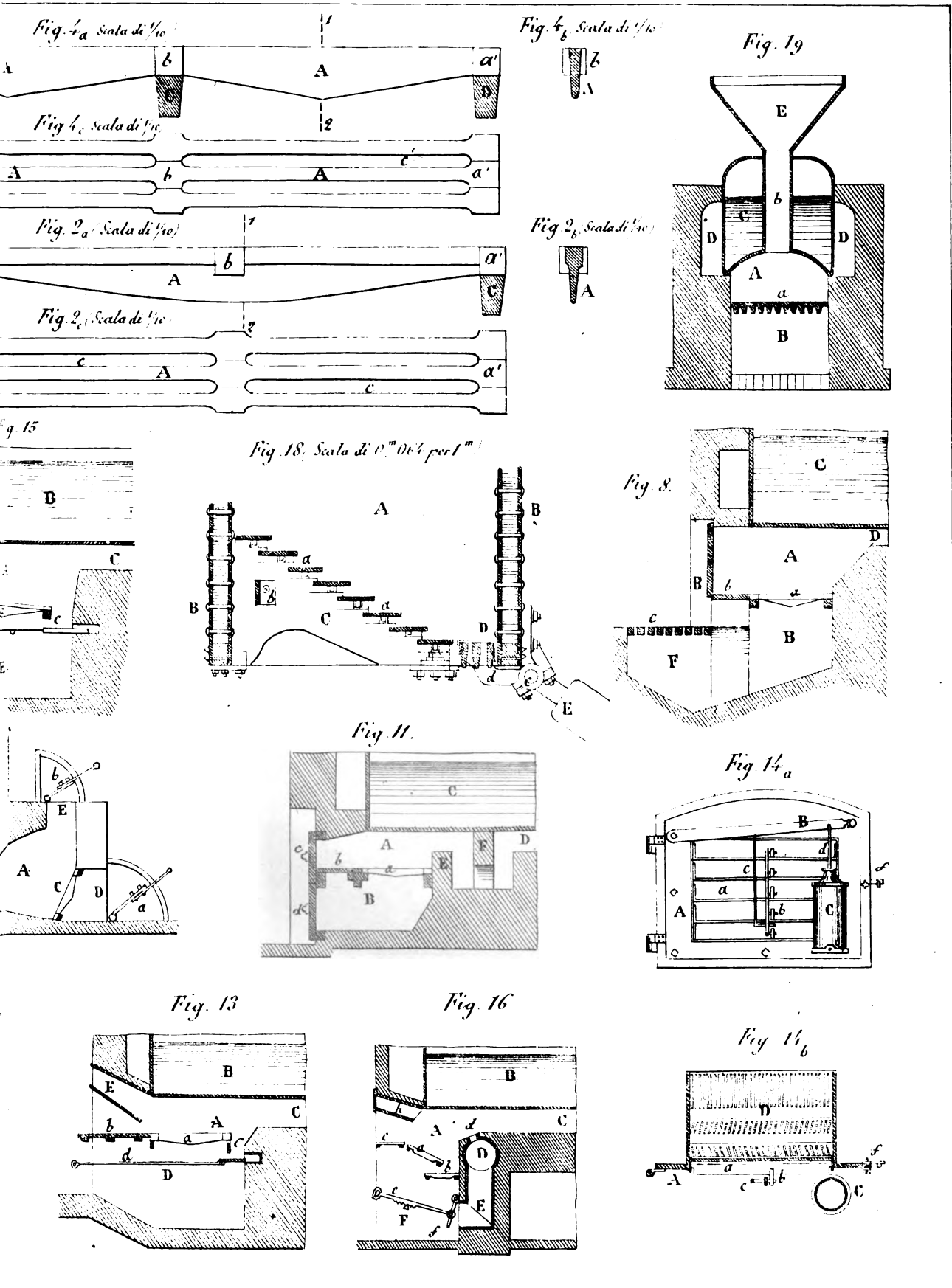

Fig. 6 (Scala di 1/24)

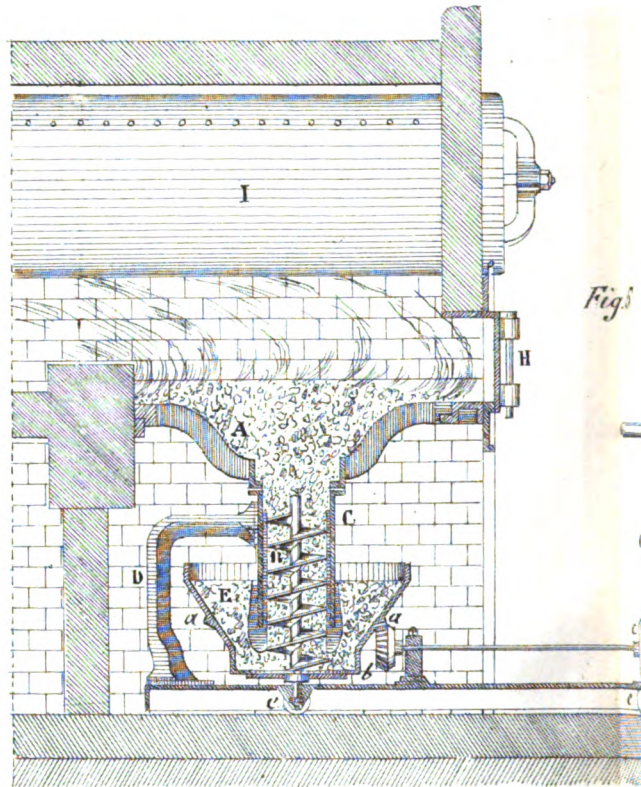
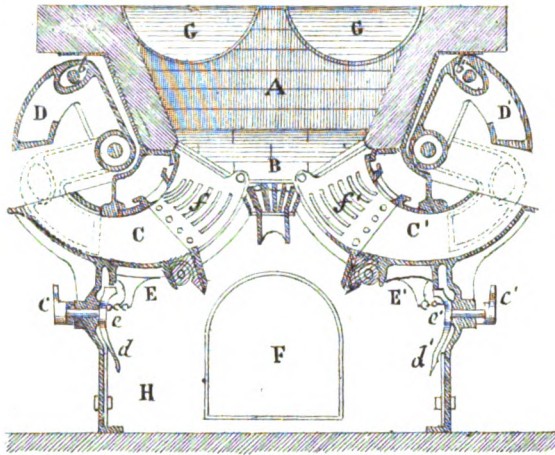

Fig. 3 (Scala di 0.035 per 1.00)

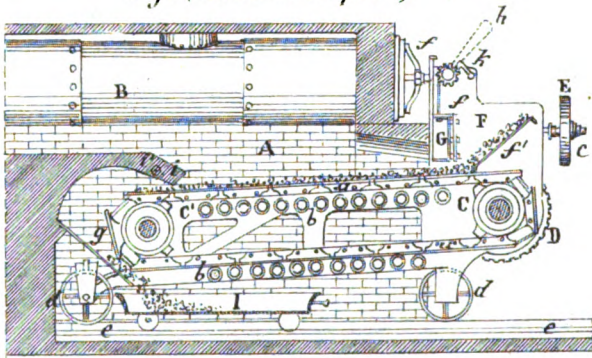

Fig. 2 (Scala di 0.105 per 1.00)

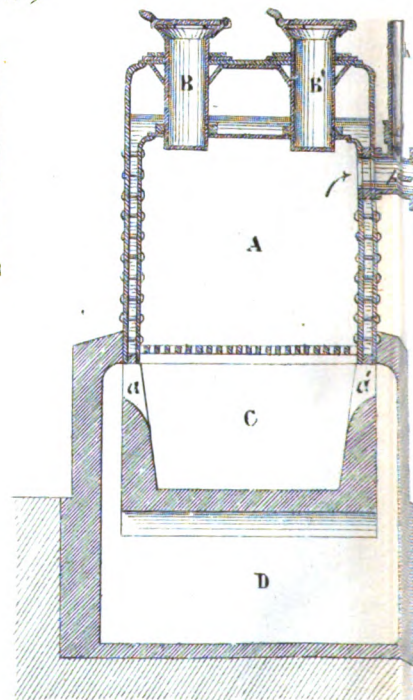
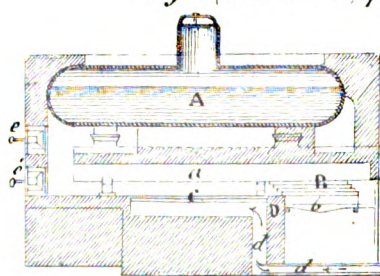
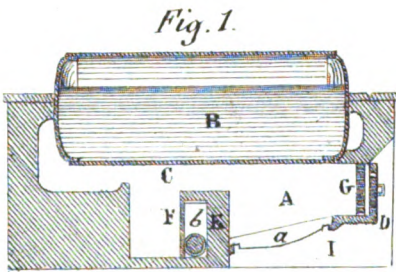

Fig. 7

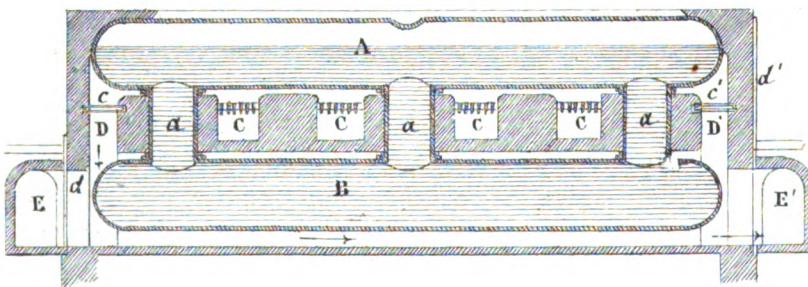

Fig. 4. (Scala di 1/30)

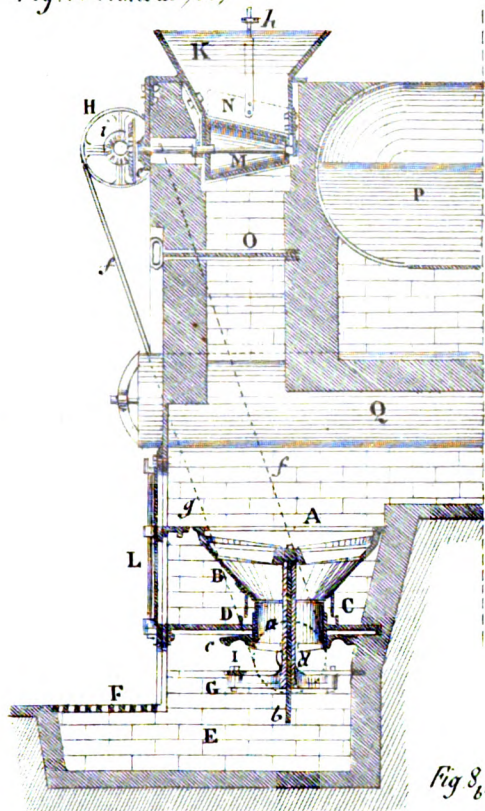

Fig. 9. (Scala di 1/25)

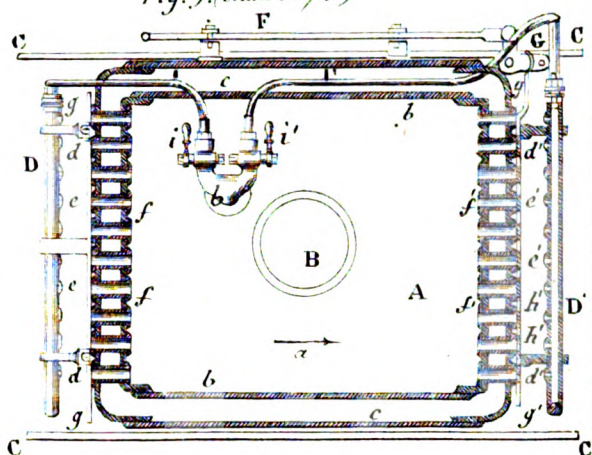

Fig. 8_a (Scala di 0^m 018 per l.^m)

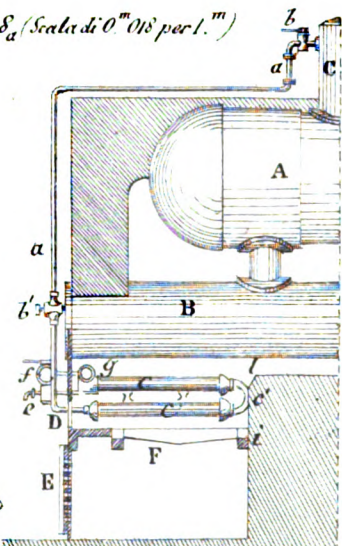

Fig. 8_b (Scala di 0^m 018 per l.^m)

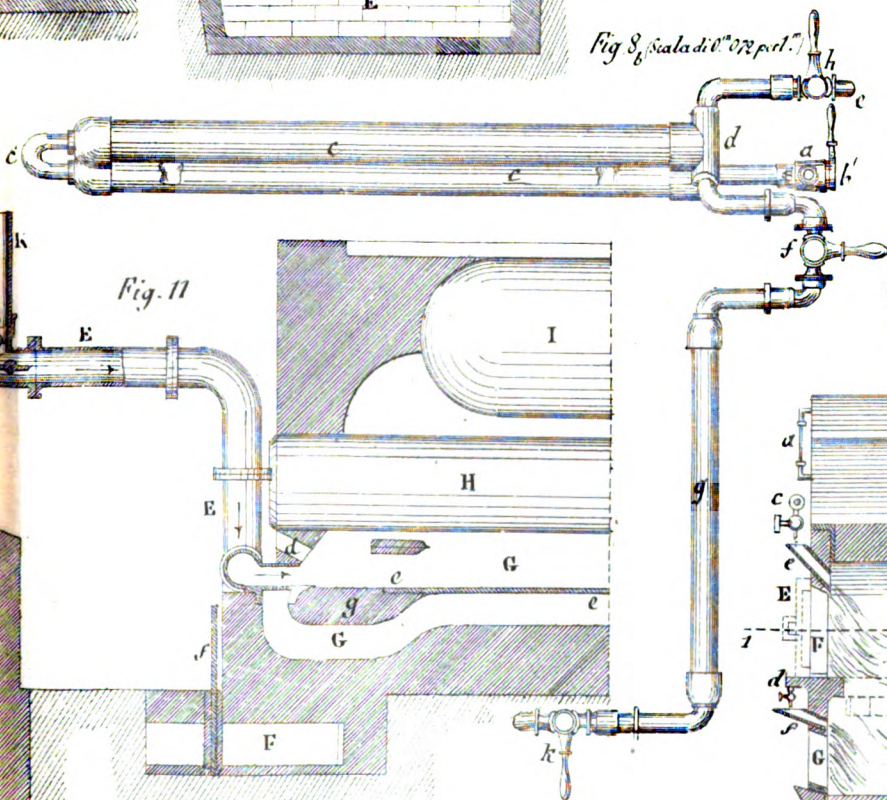

Fig. 10_a (Scala di 1/25)

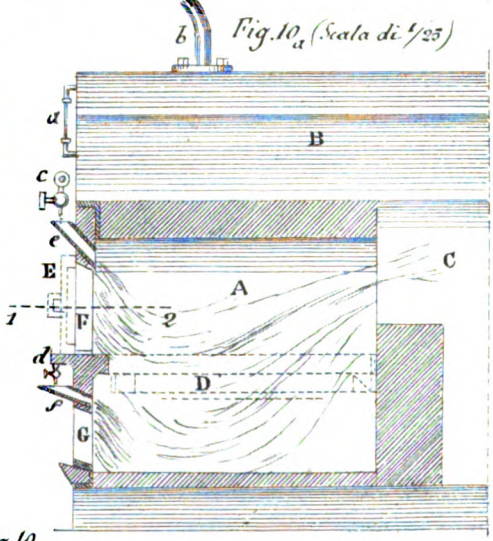

Fig. 10_b (Scala di 0^m 018 per l.^m)



Fig. 11

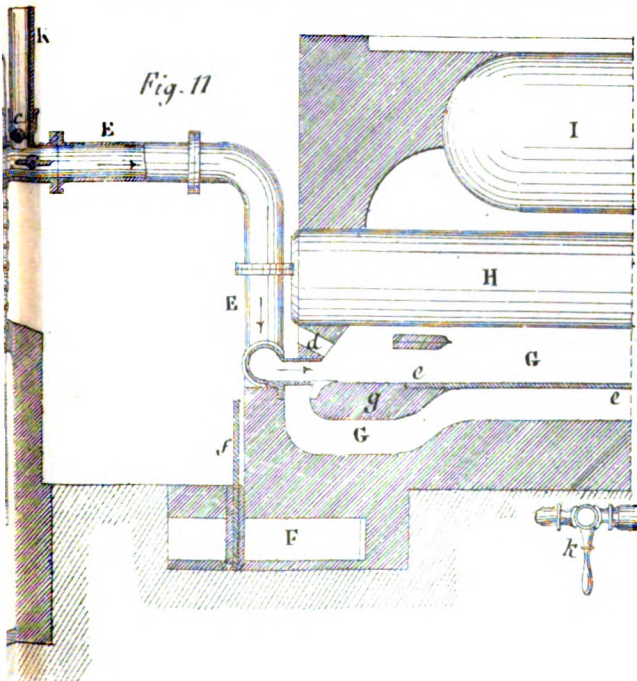

Fig. 11_b (Scala di 0" 015 per 1")

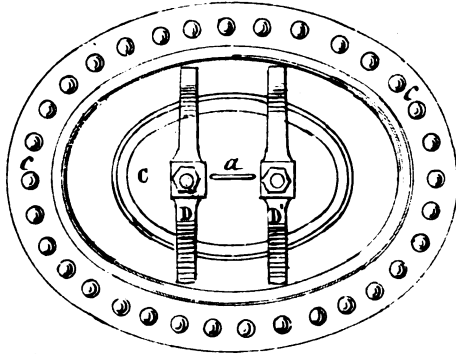

Fig. 12_b (Scala di 0" 015 per 1")

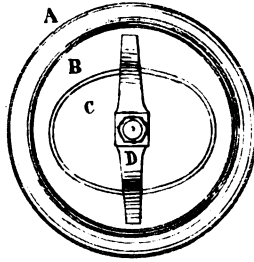

Fig. 13 (Scala di 0" 015 per 1")

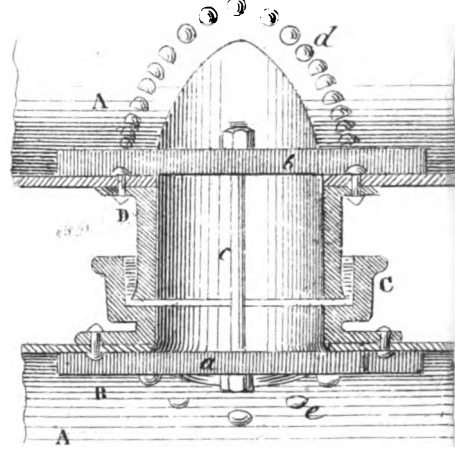

Fig. 11_a

(Scala di 0" 015 per 1")

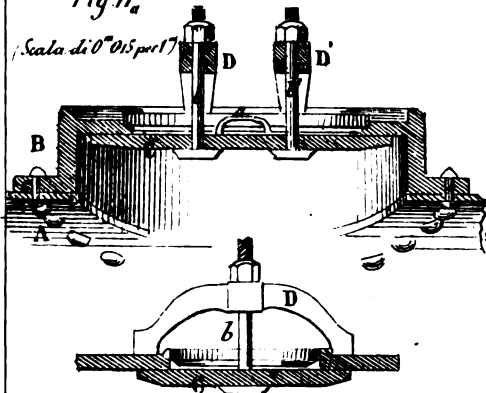

Fig. 12_a (Scala di 0" 015 per 1")

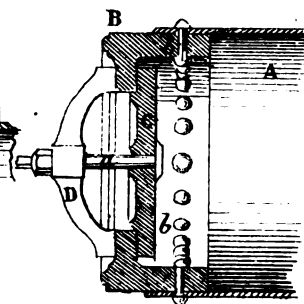

Fig. 13_a (Scala di 0" 015 per 1")

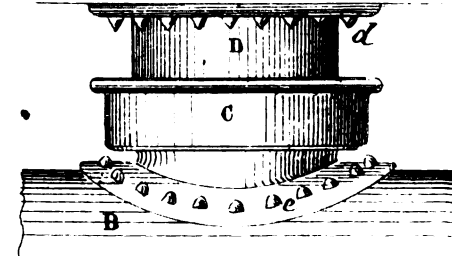

Fig. 8 (Scala di 1/4)

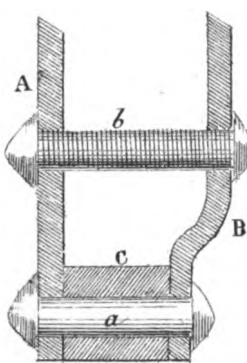

Fig. 5_b (Scala di 1/4)

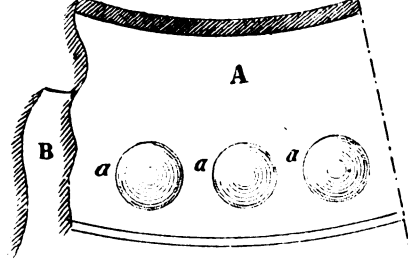

Fig. 7_b (Scala di 1/4)

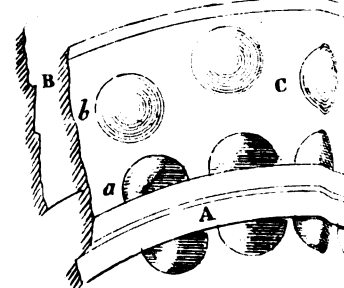

Fig. 5_a (Scala di 1/4)

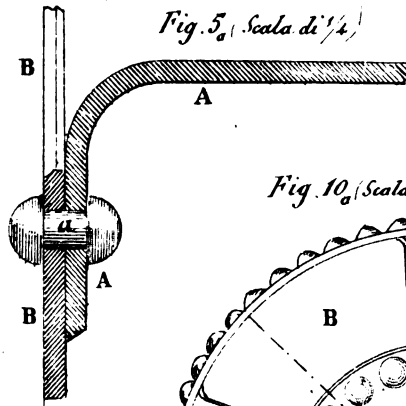

Fig. 3 (Scala di 1/4)



Fig. 9 (Scala di 1/4)

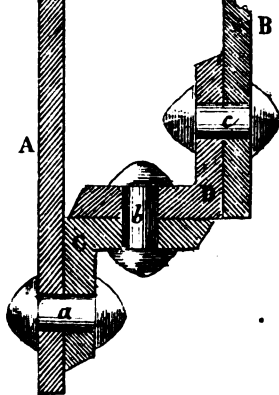

Fig. 10_a (Scala di 1/10)

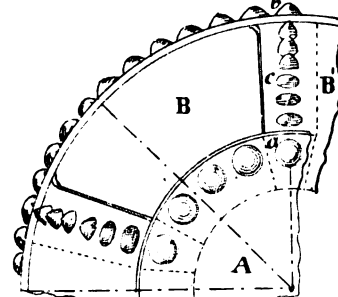

Fig. 10_b (Scala di 1/10)

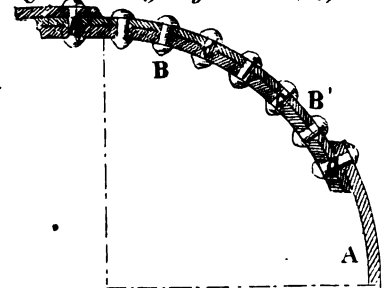

Fig. 1 (Scala di 1/4)

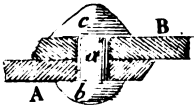

Fig. 2 (Scala di 1/4)



Fig. 4 (Scala di 1/4)

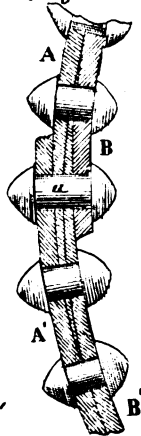

Fig. 4a (Scala di 1/4)

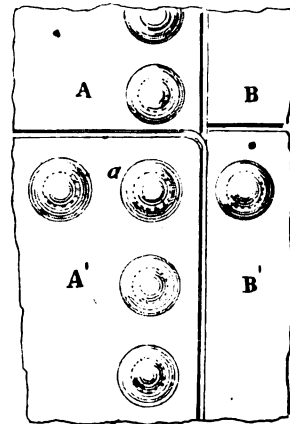

Fig. 14

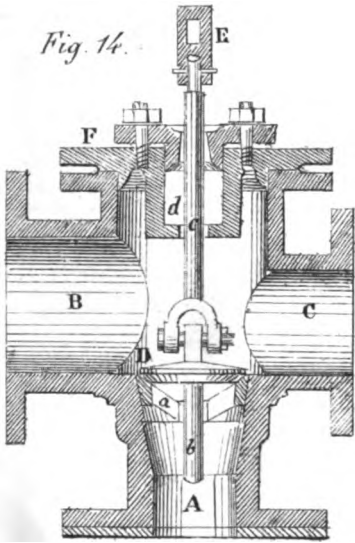

Fig. 15

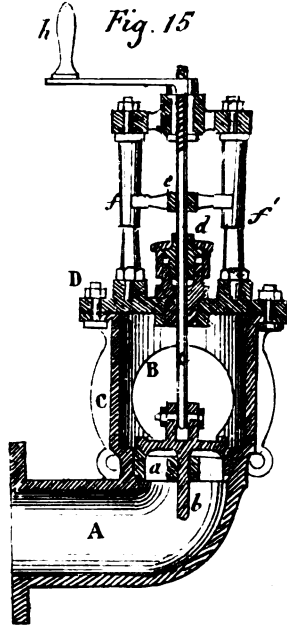
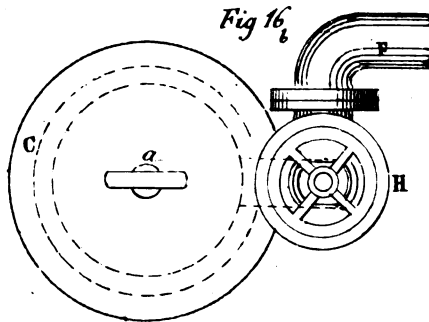

Fig. 16



Scala di 1/4

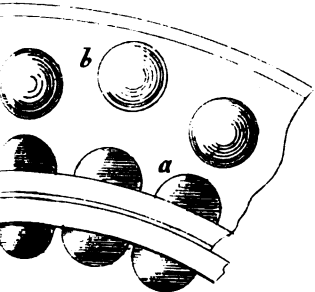

Fig. 6 (Scala di 1/4)

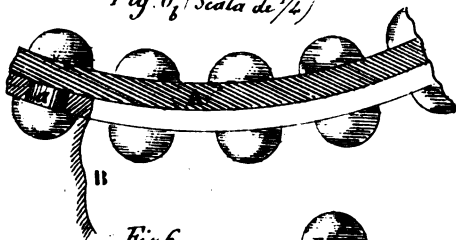

Fig. 6a (Scala di 1/4)

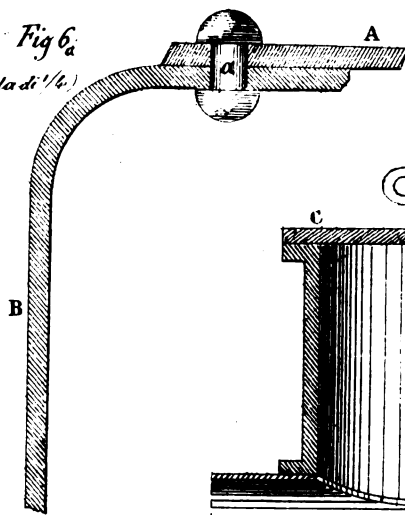

Fig. 16a

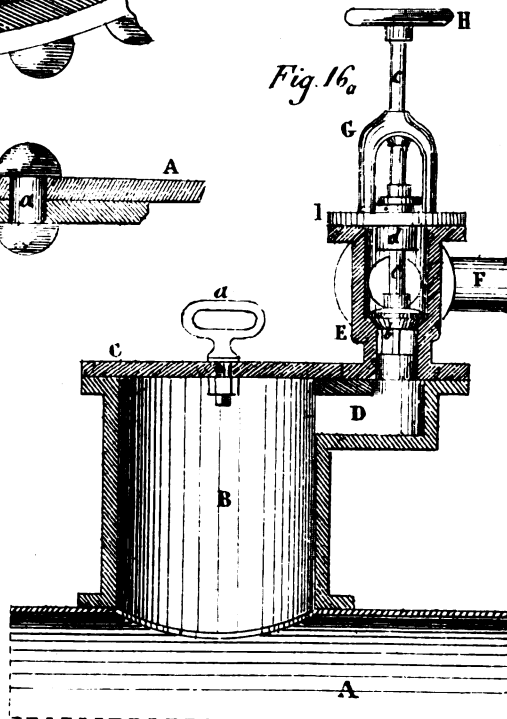
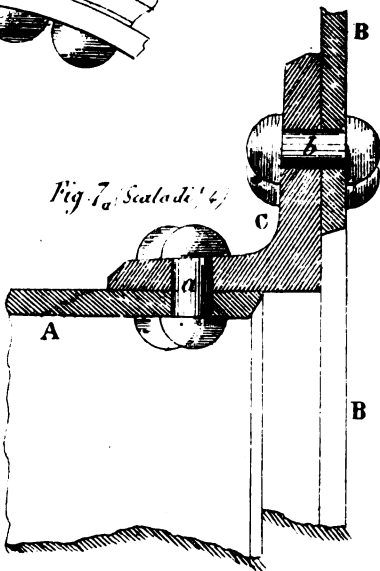
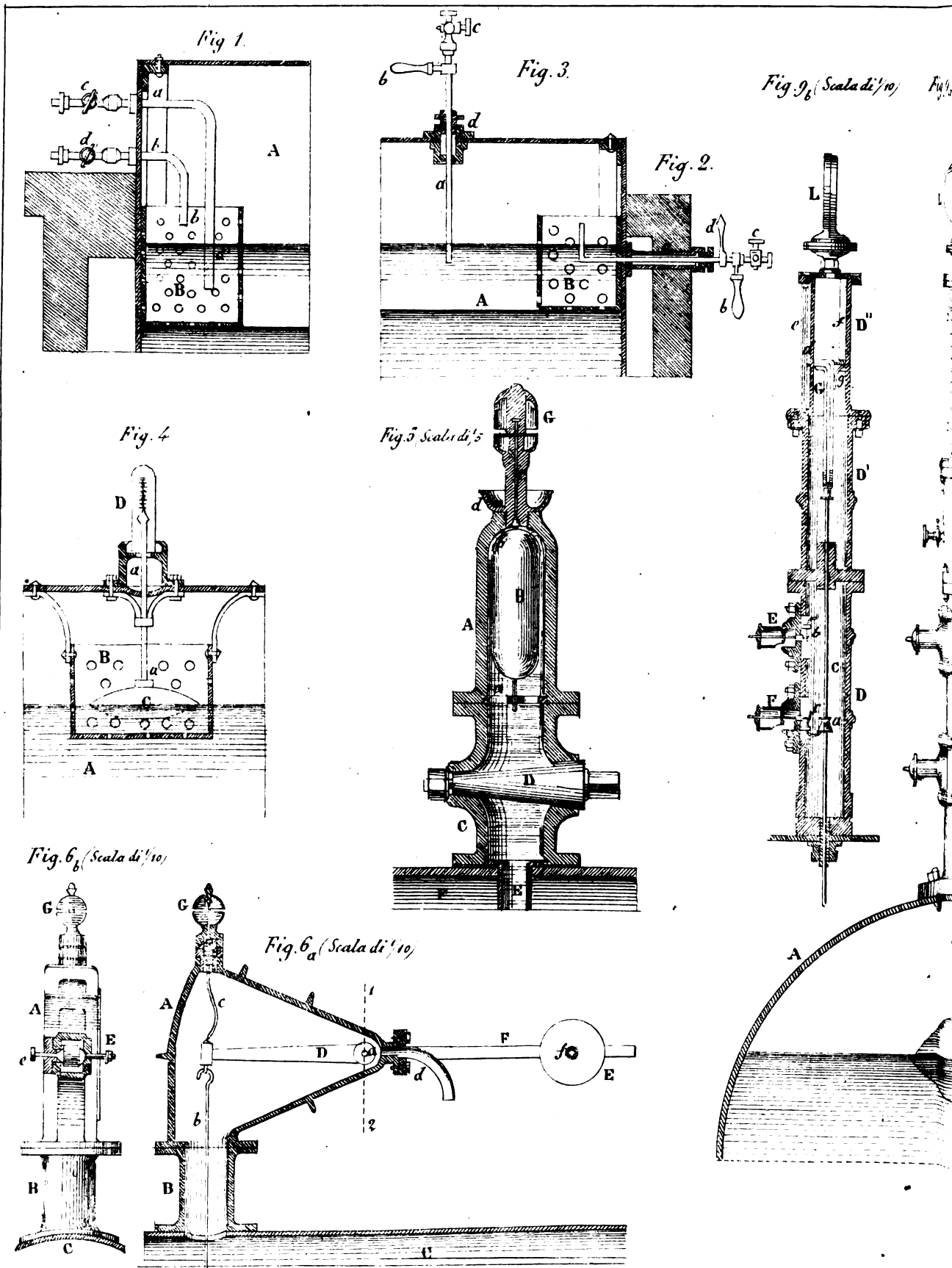

Fig. 7a (Scala di 1/4)





Bagnoli Cesare dis

Torino Lit. P. Briola Vie.

Fig. 9_a (Scala di 1/10)

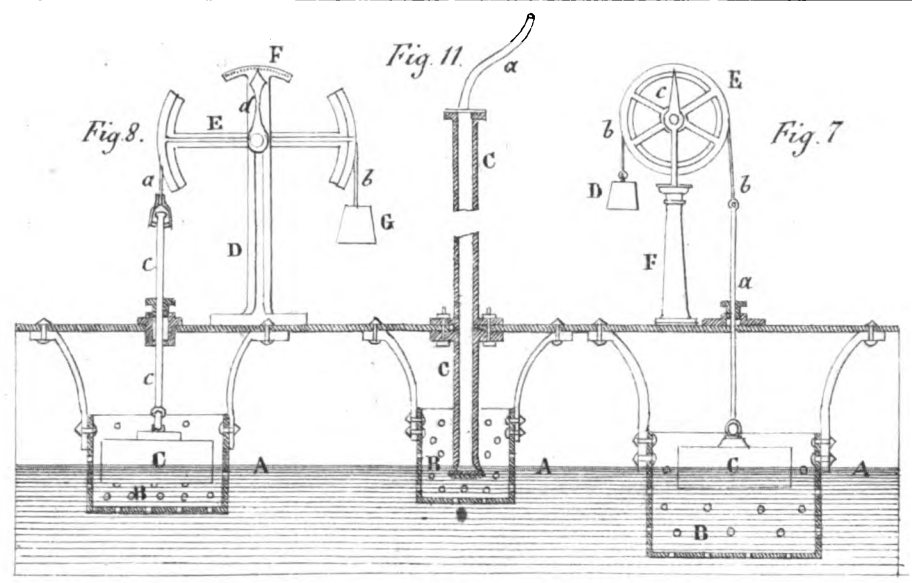
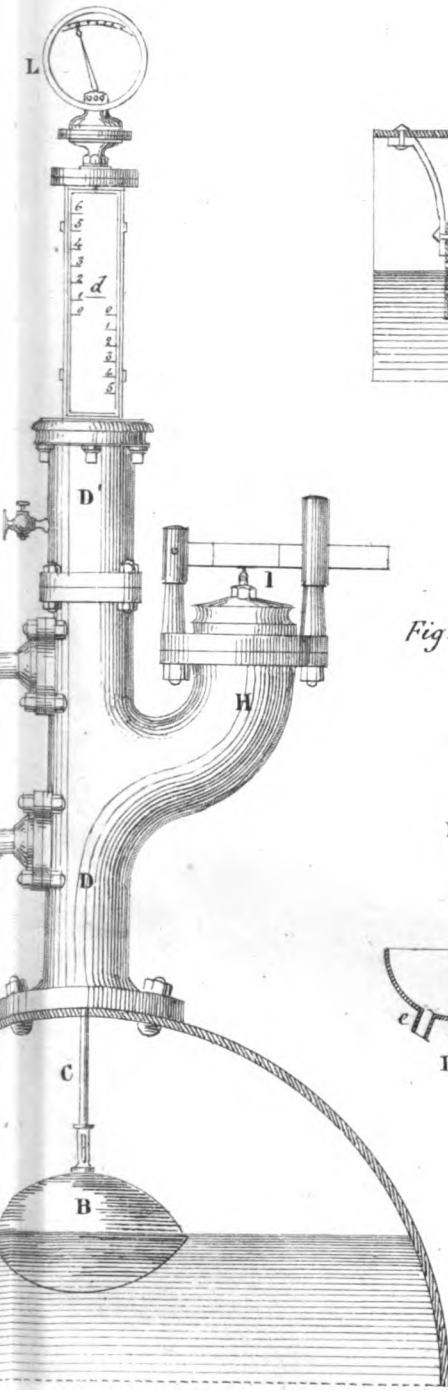

Fig. 10_a (Scala di 1/5). Fig. 10_b (Scala di 1/5)

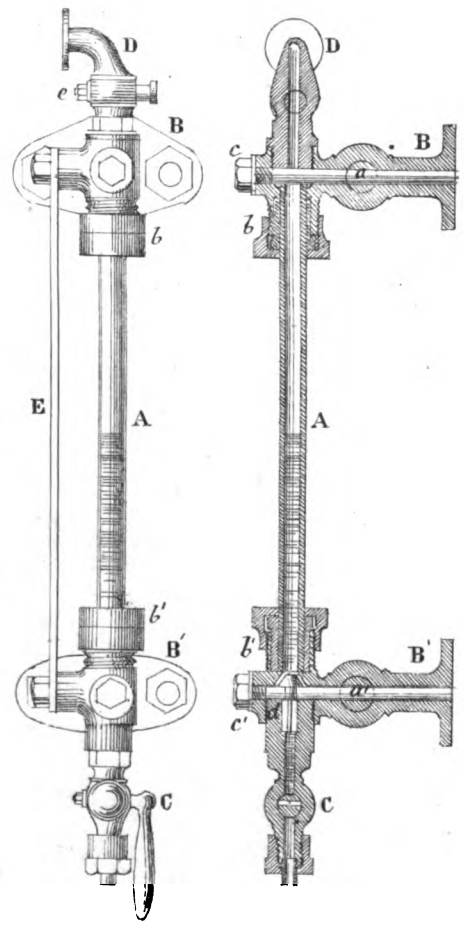
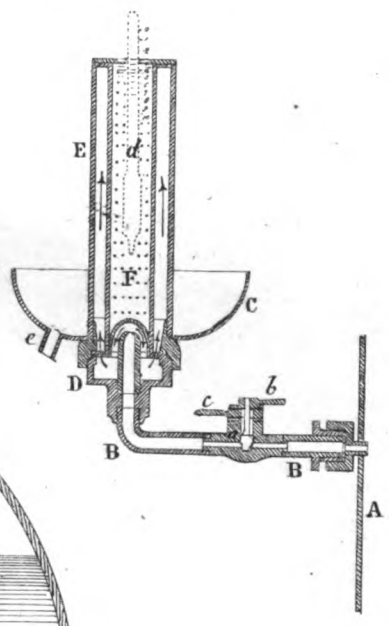
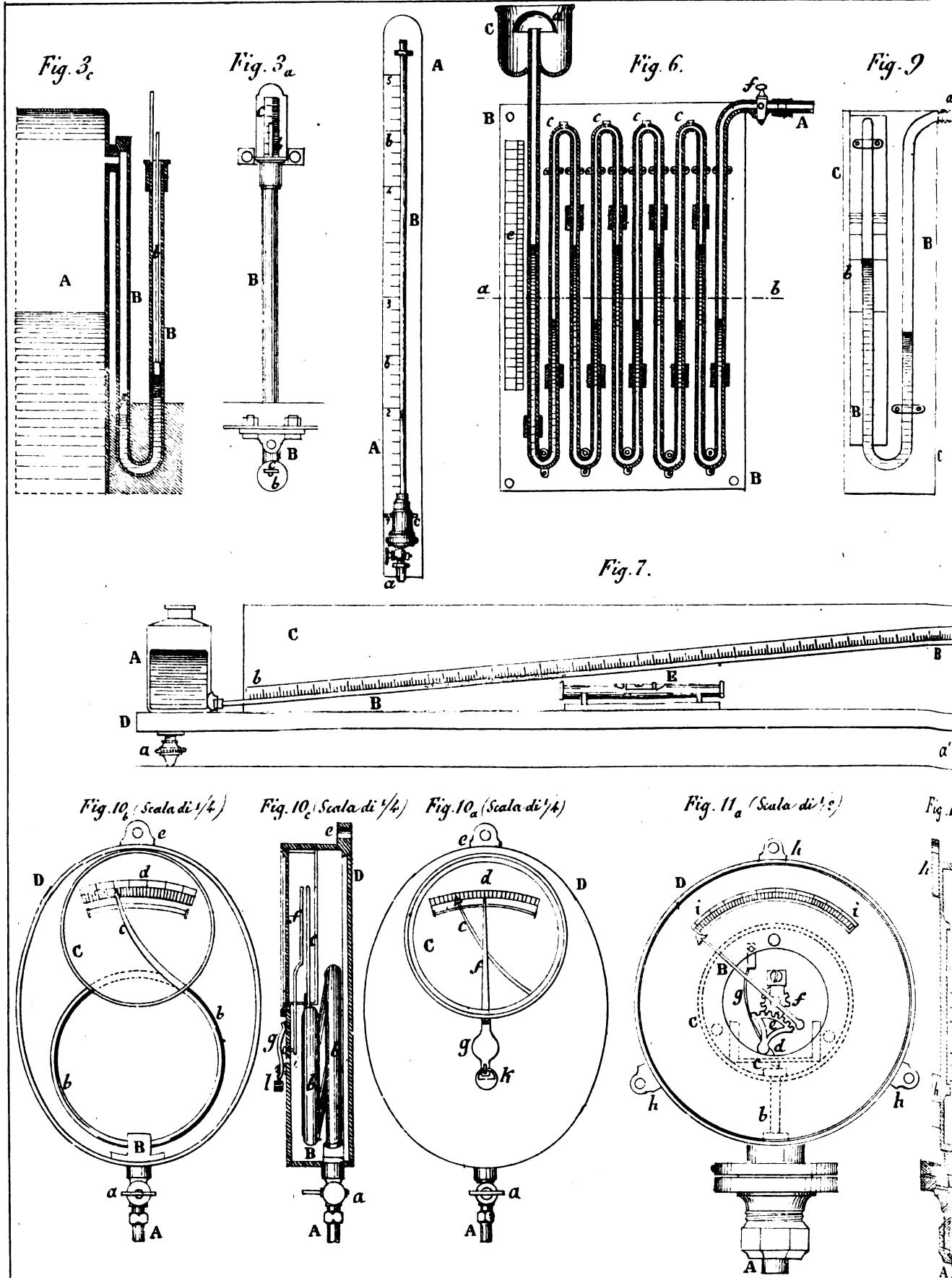
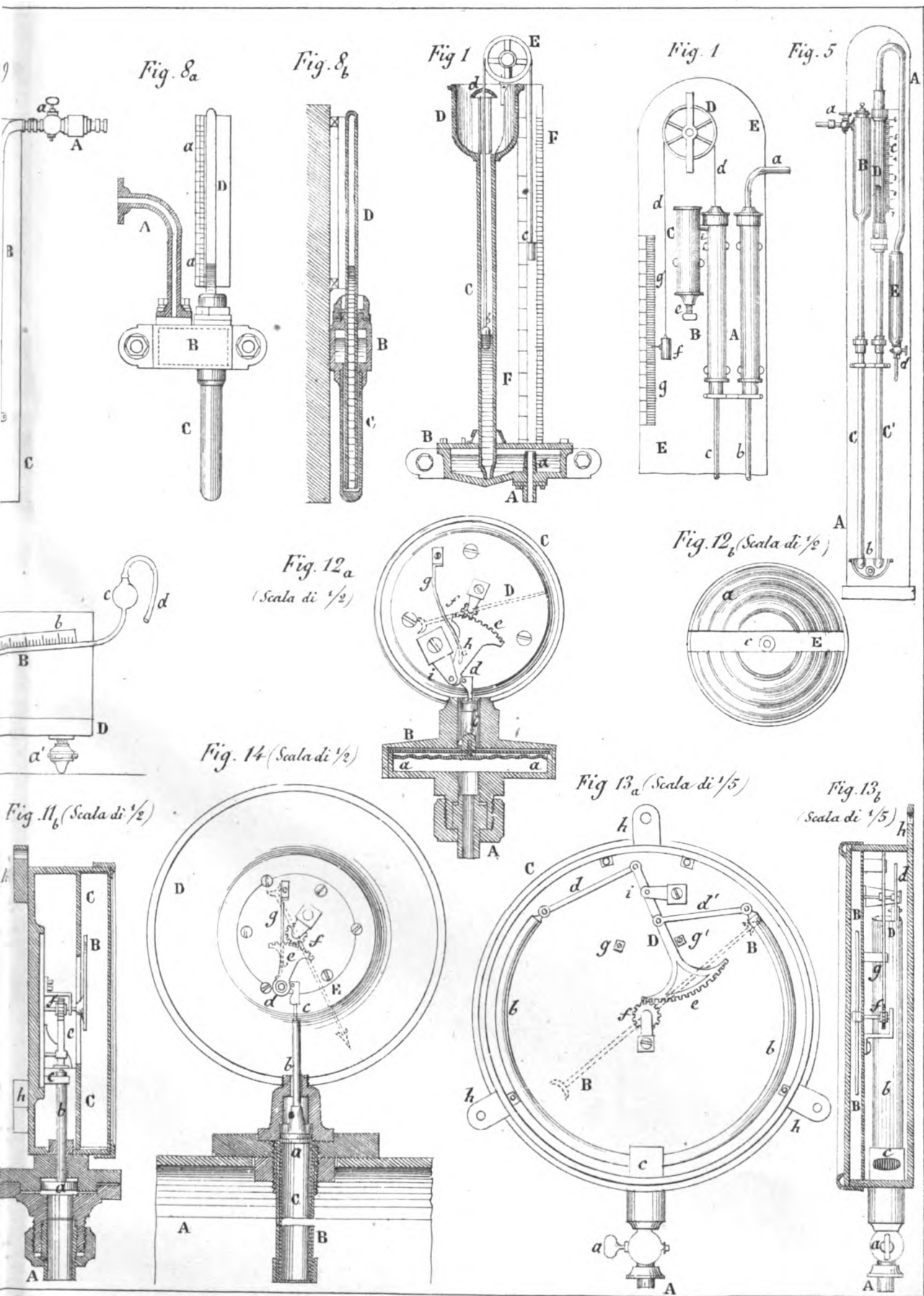
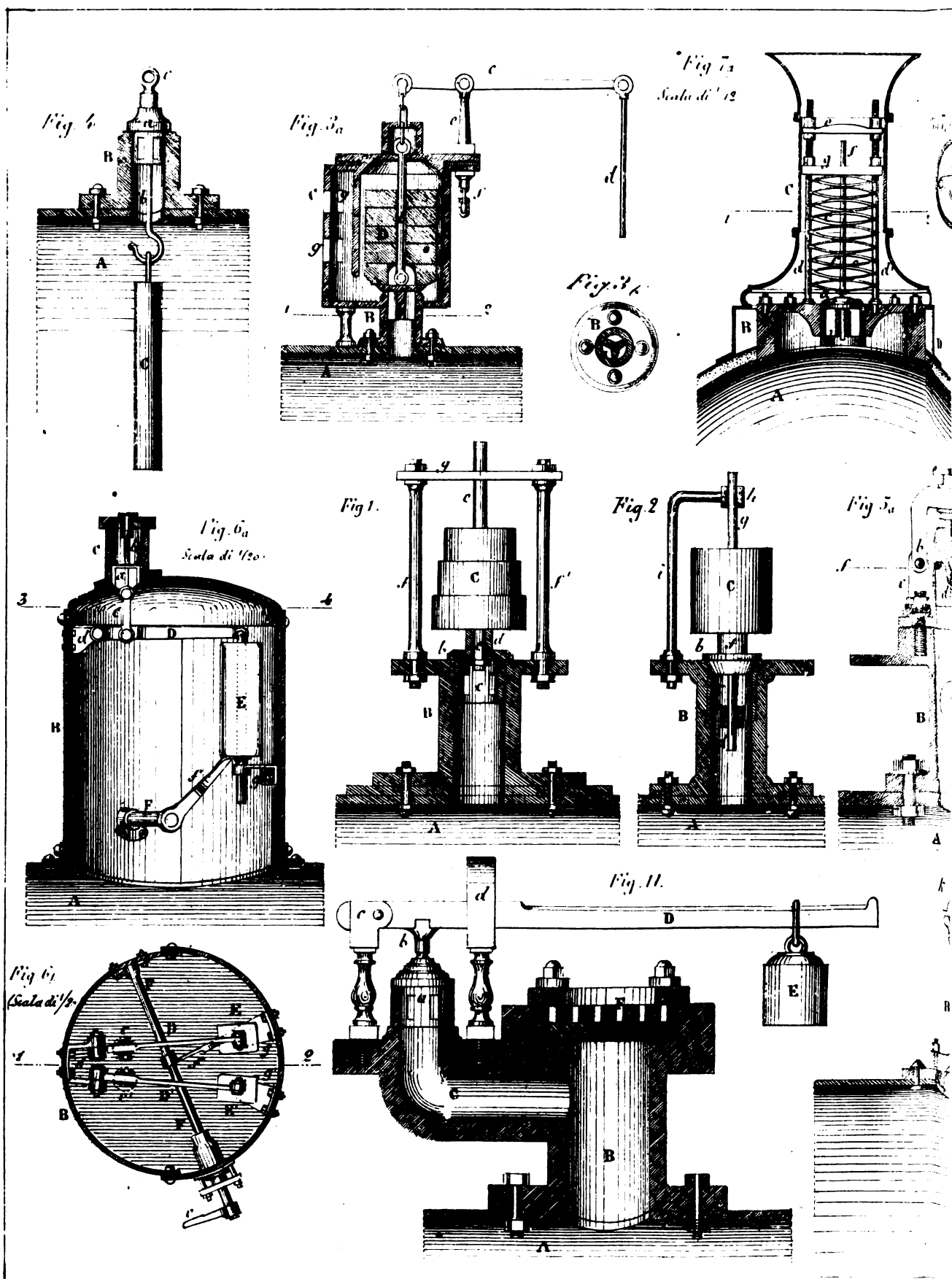

Fig. 12 (Scala di 1/6)









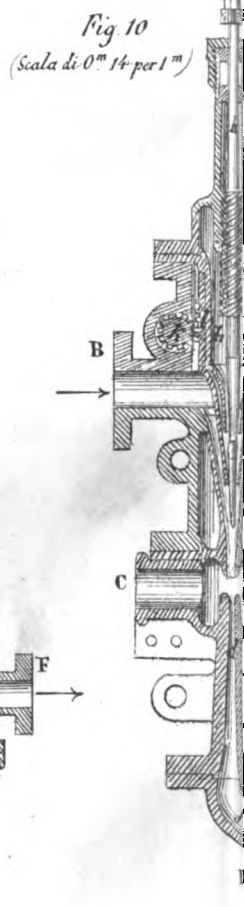
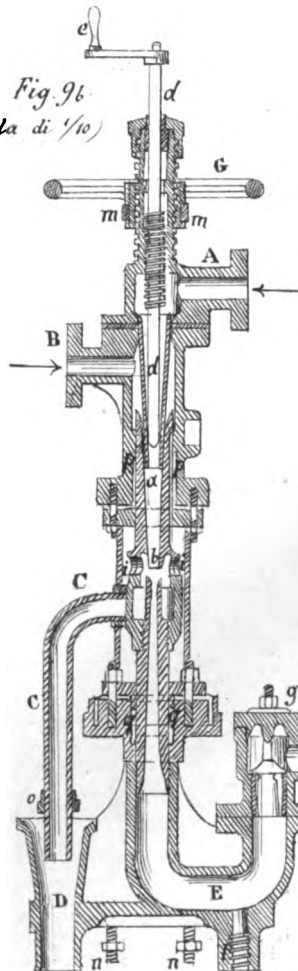
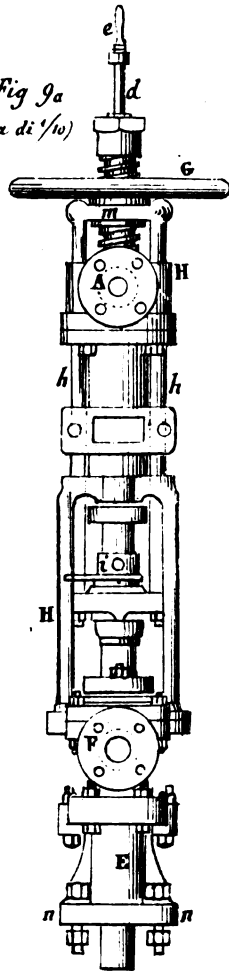
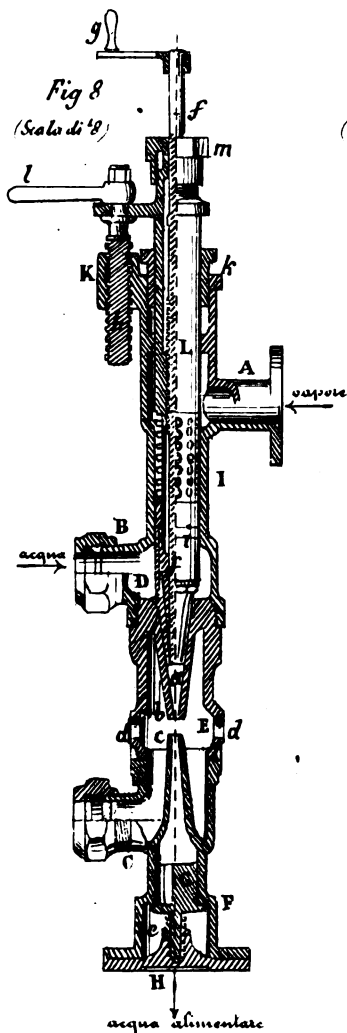
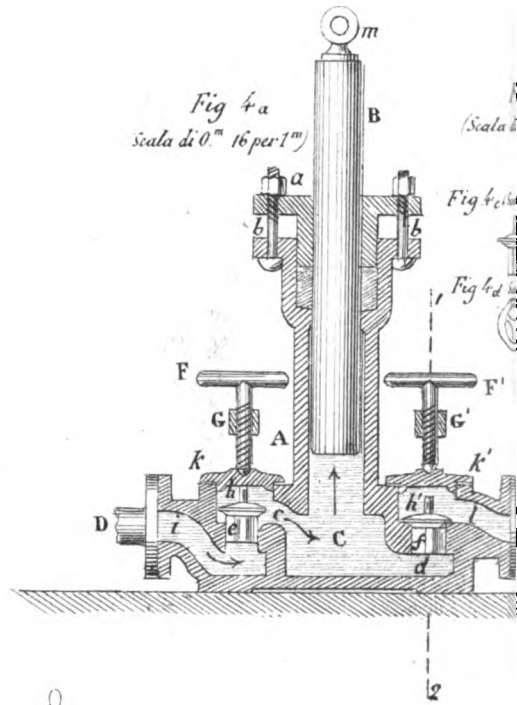
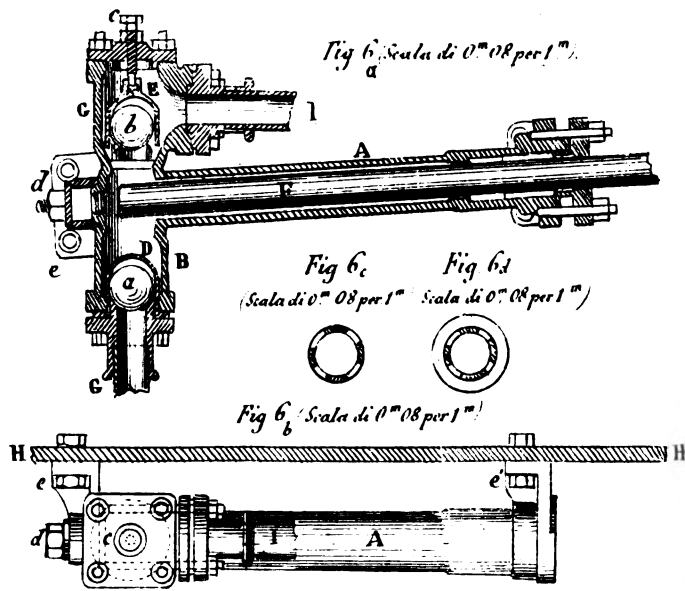

Adolfo Bertola dis.

Torino Lit. P. Briola via S. F.

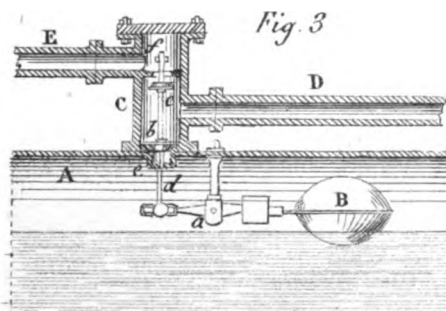
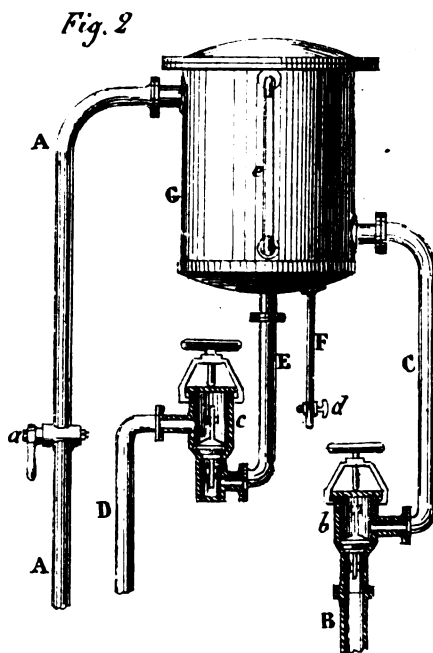
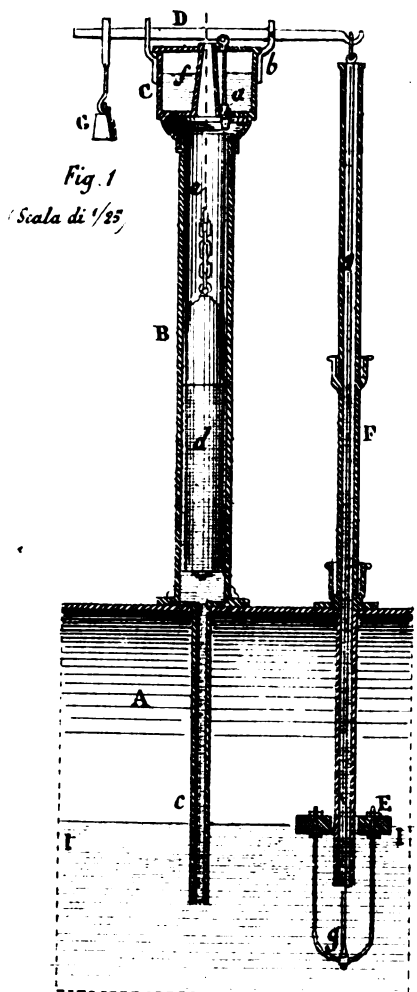
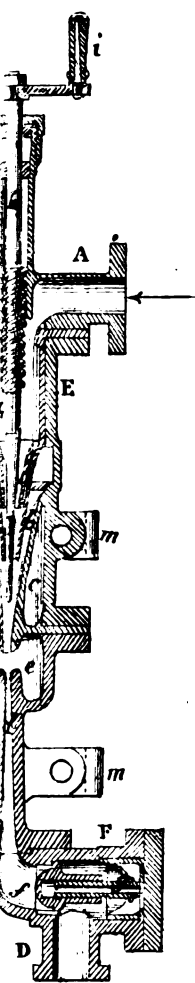
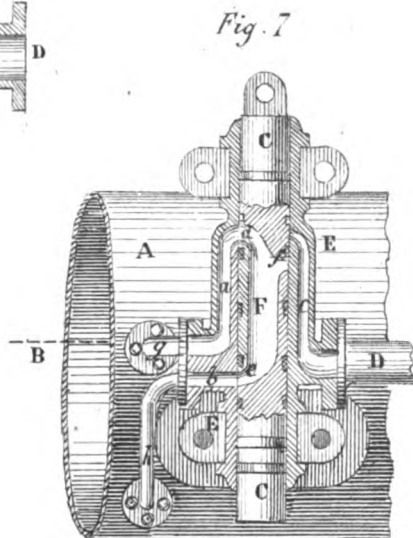
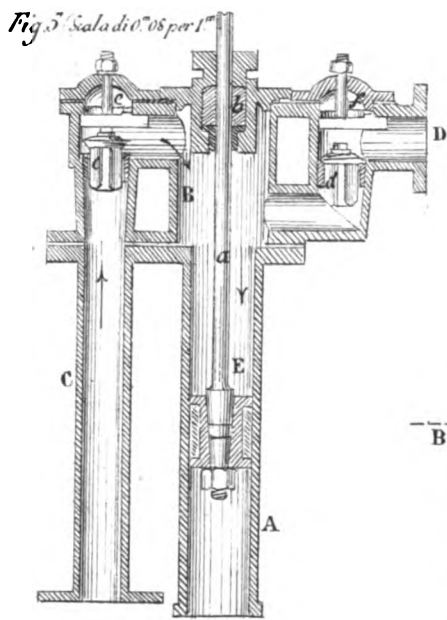
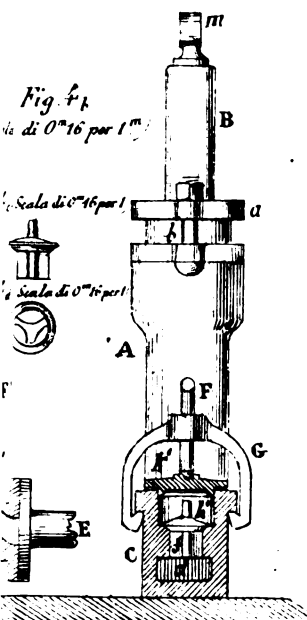

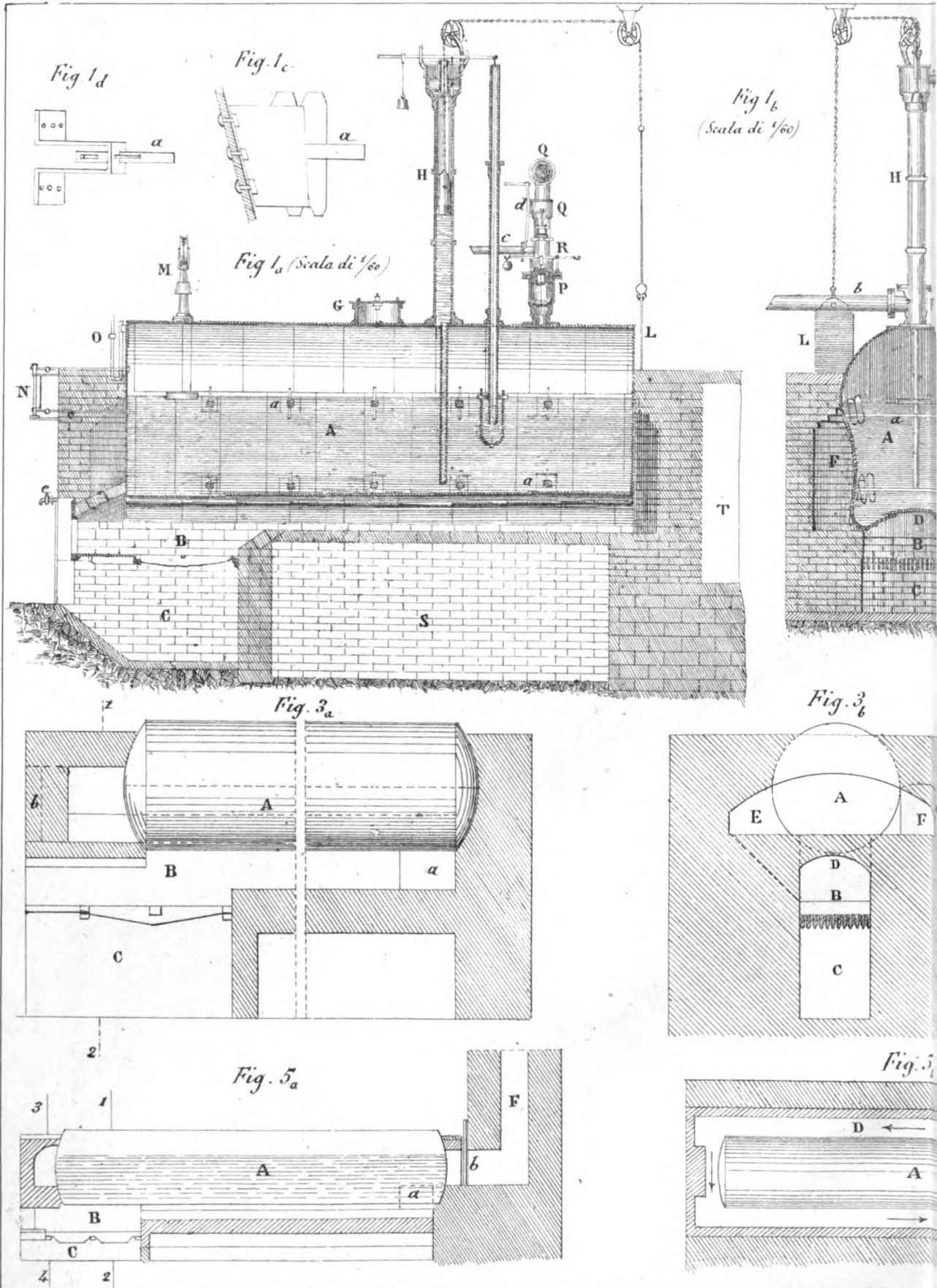

Ercole Visconti Prasca dis

Lit. P. F. Biondi via S. Francesco

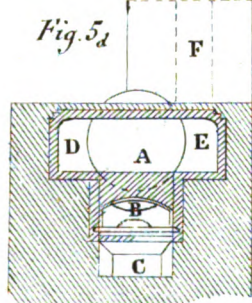
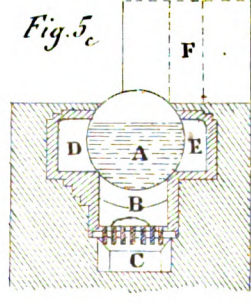
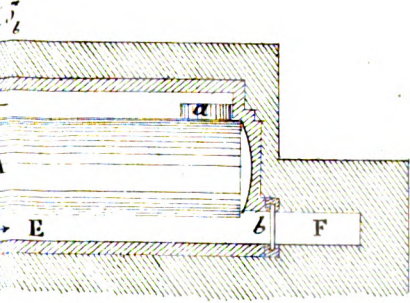
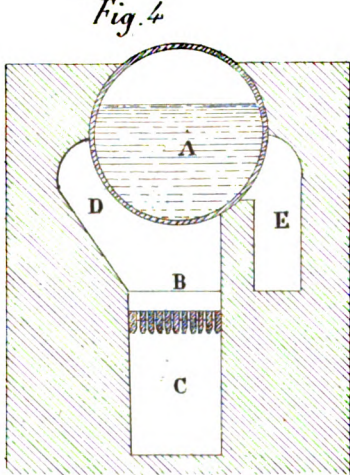
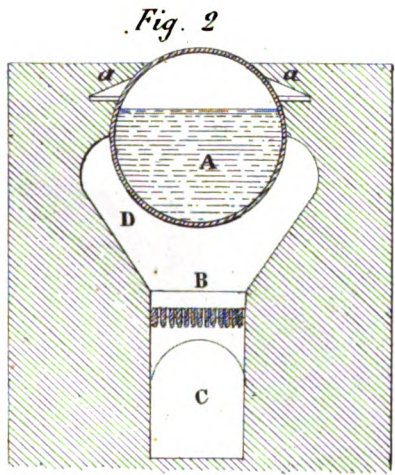
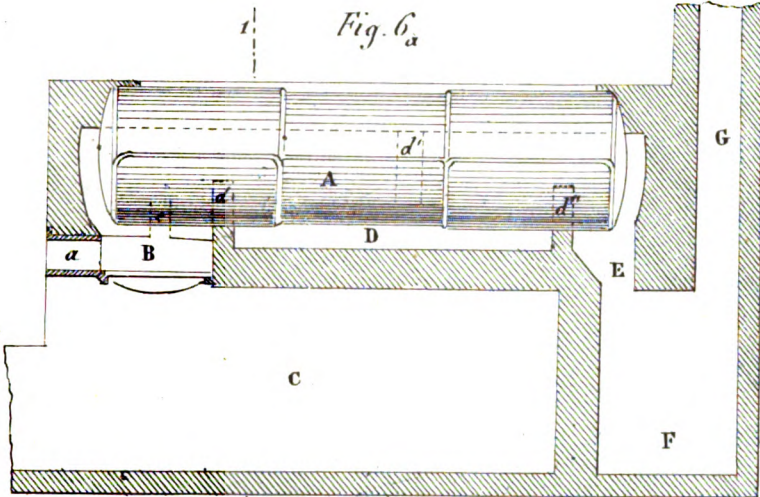
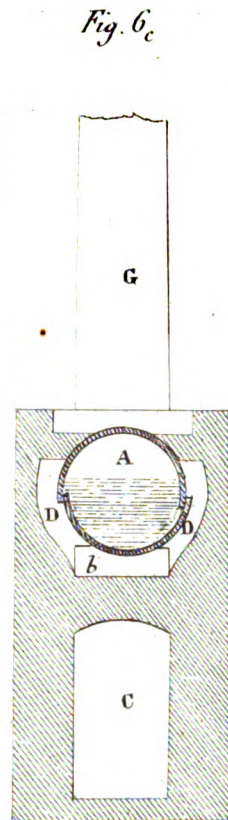
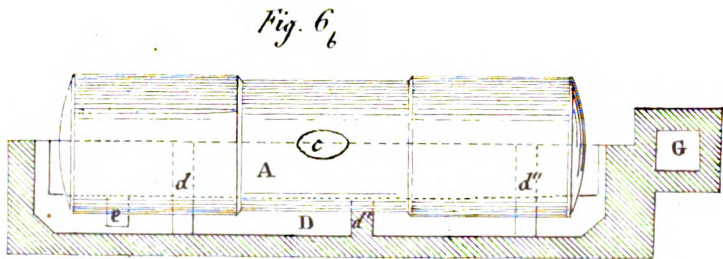
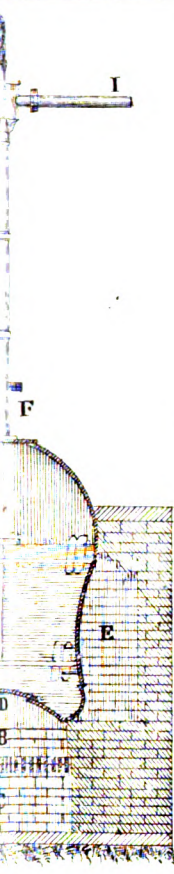

Fig. 2_b (Scala di 0^m.015 per l^m.)

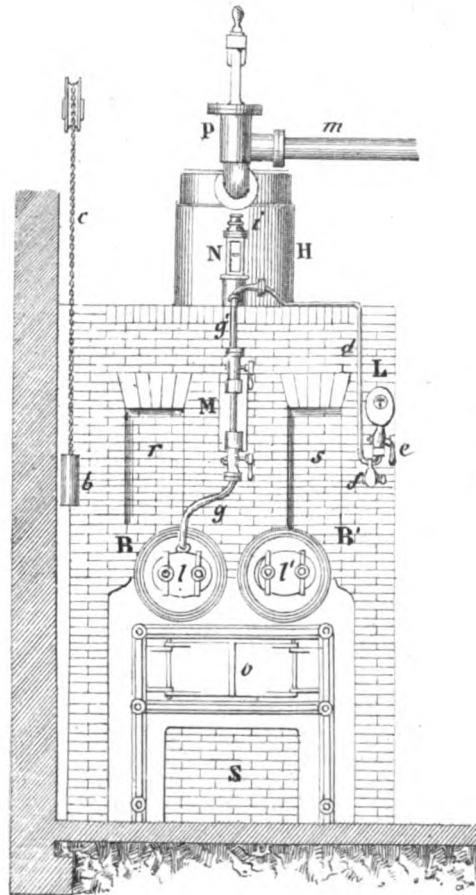

Fig. 2_a (Scala di 0^m.015 per l^m.)

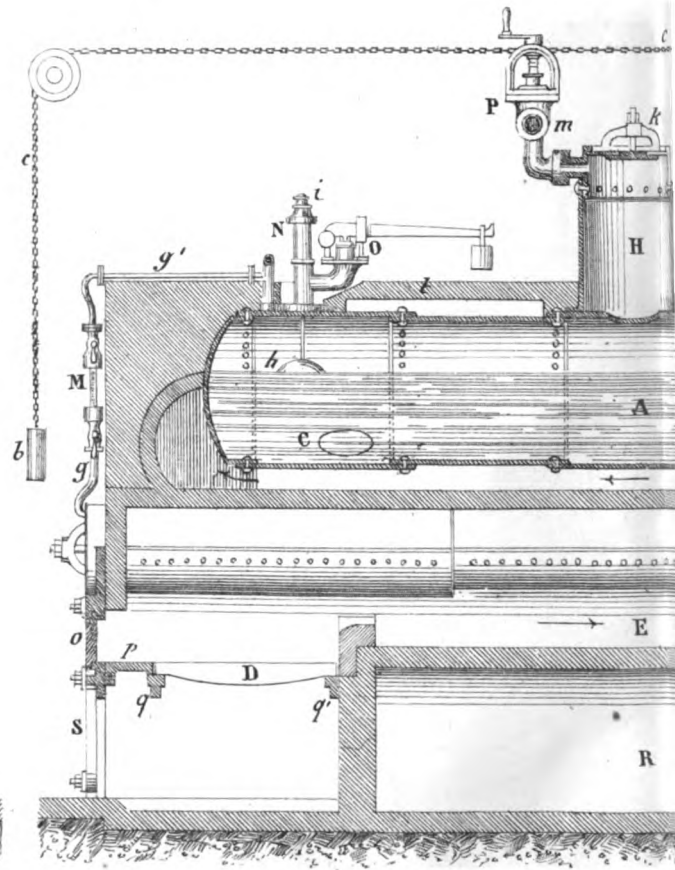

Fig. 1_a (Scala di 1/50.)

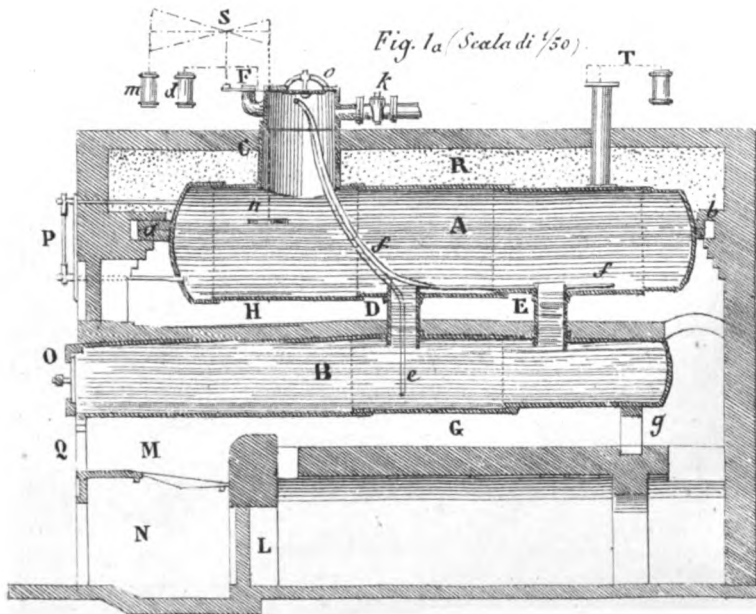
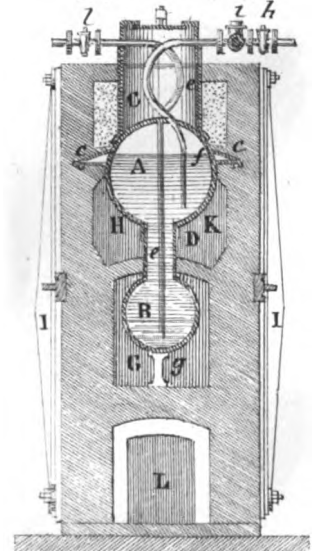

Fig. 1_b (Scala di 1/50.)



1^m.

Fig. 2_c (Scala di 0^m015 per 1^m).

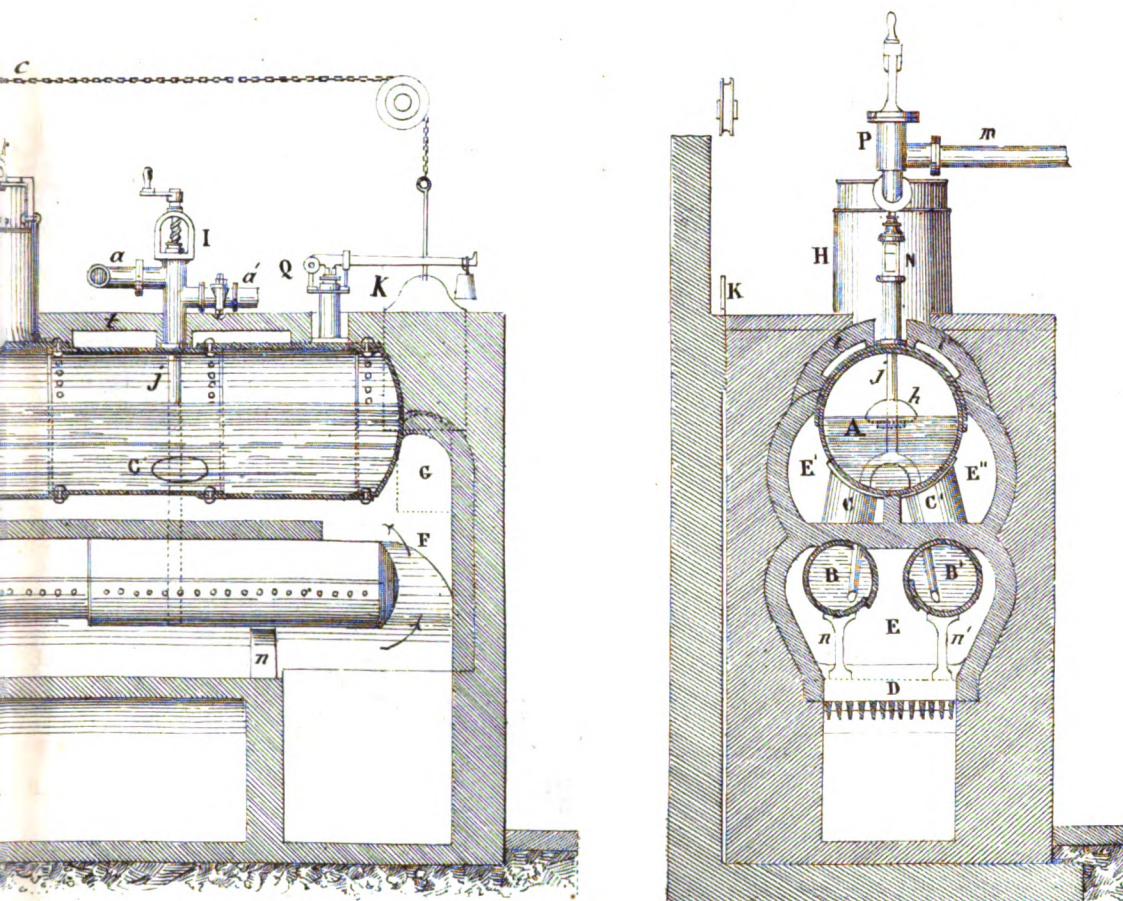

Fig. 3_a.

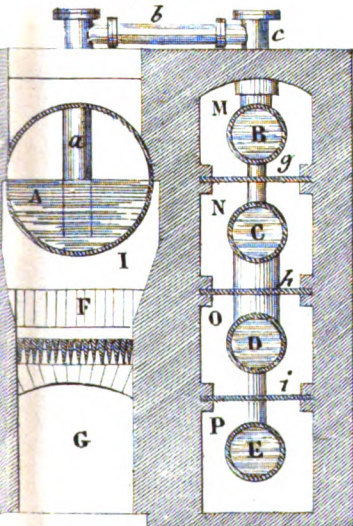
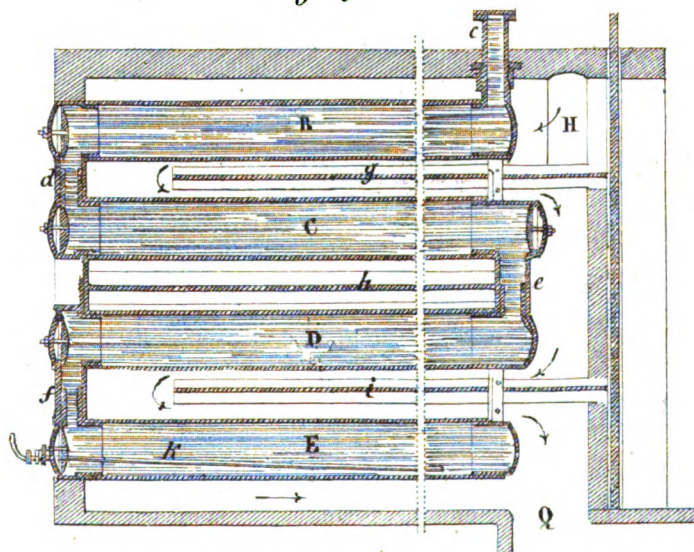
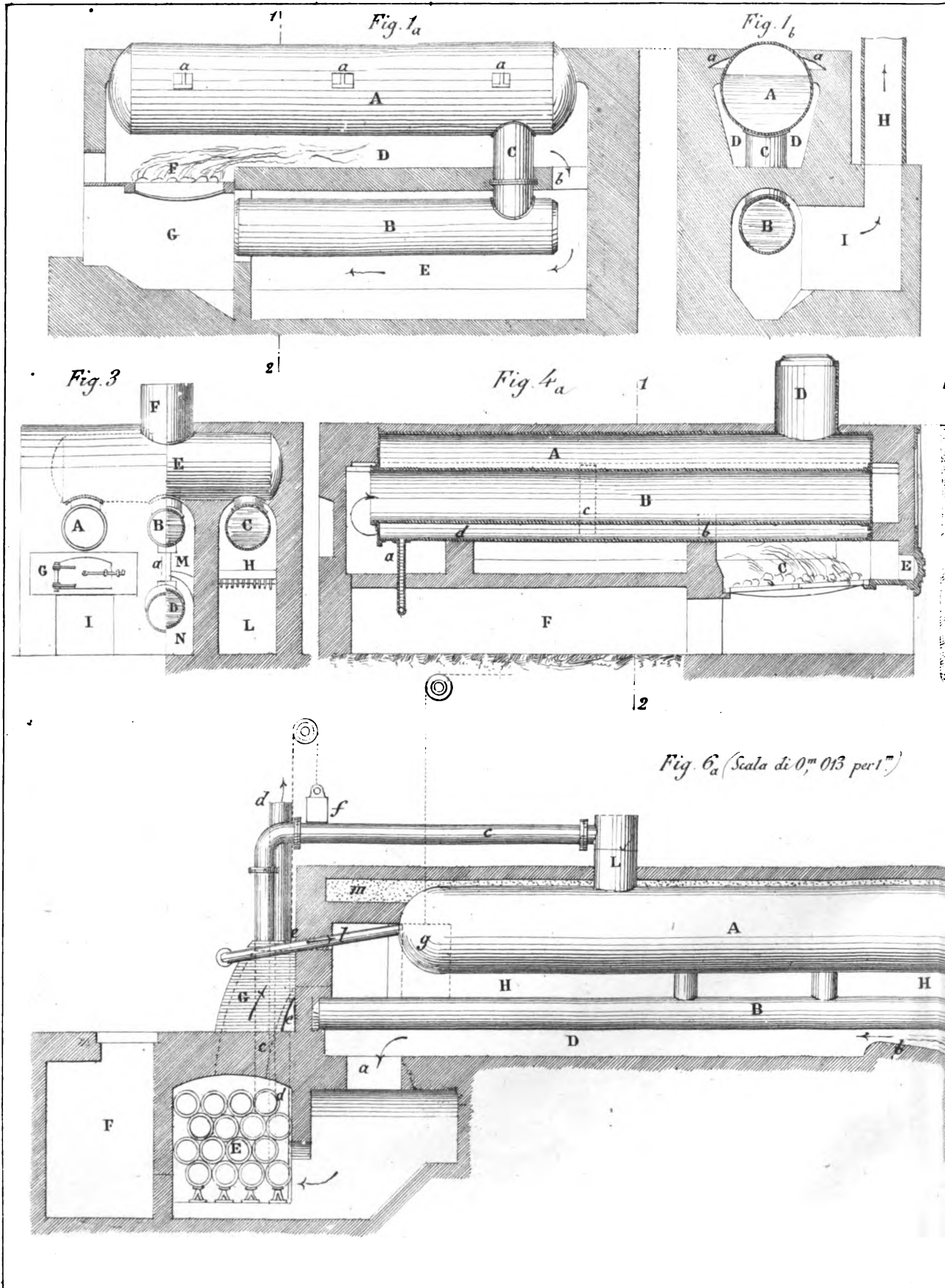

Fig. 3_b.





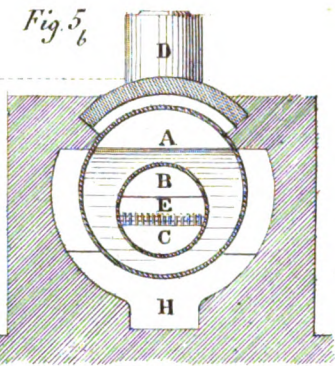
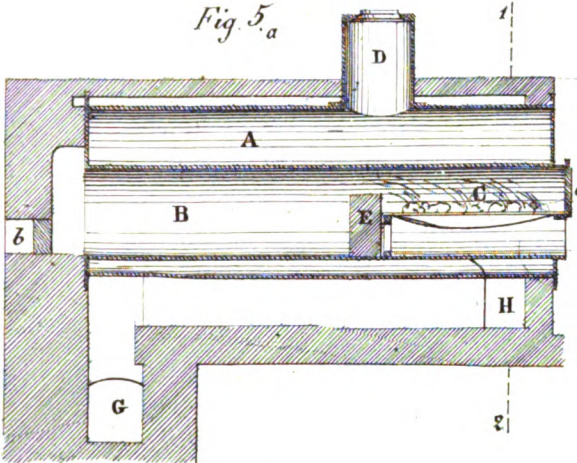
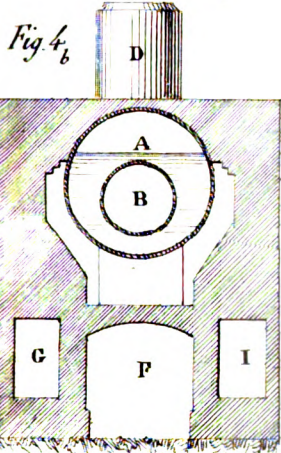
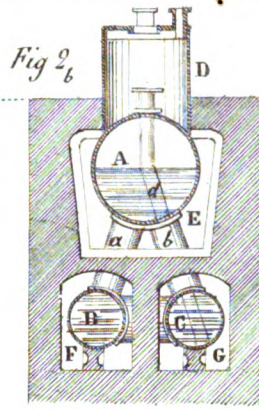
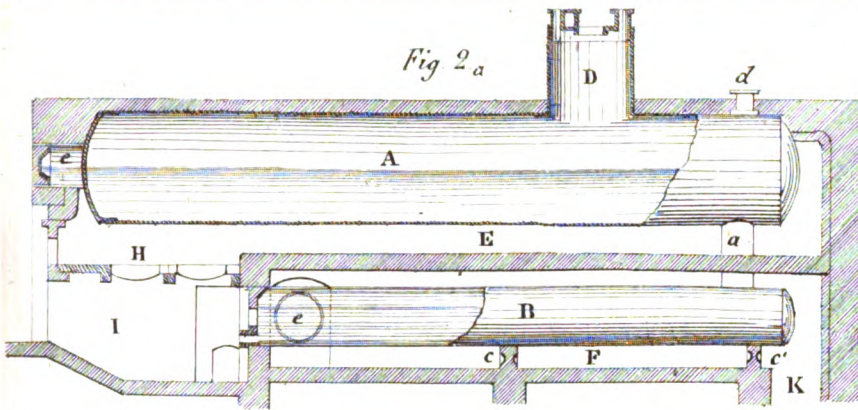
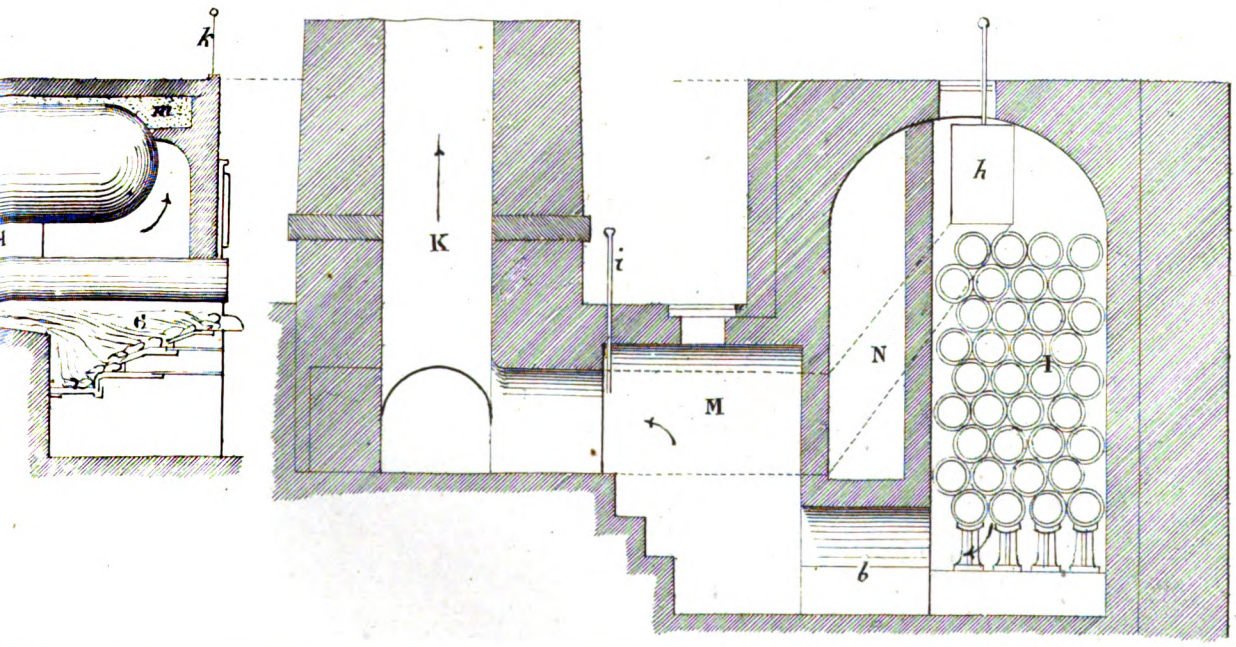

Fig. 6 (Scala di 0,013 per 1.^o)



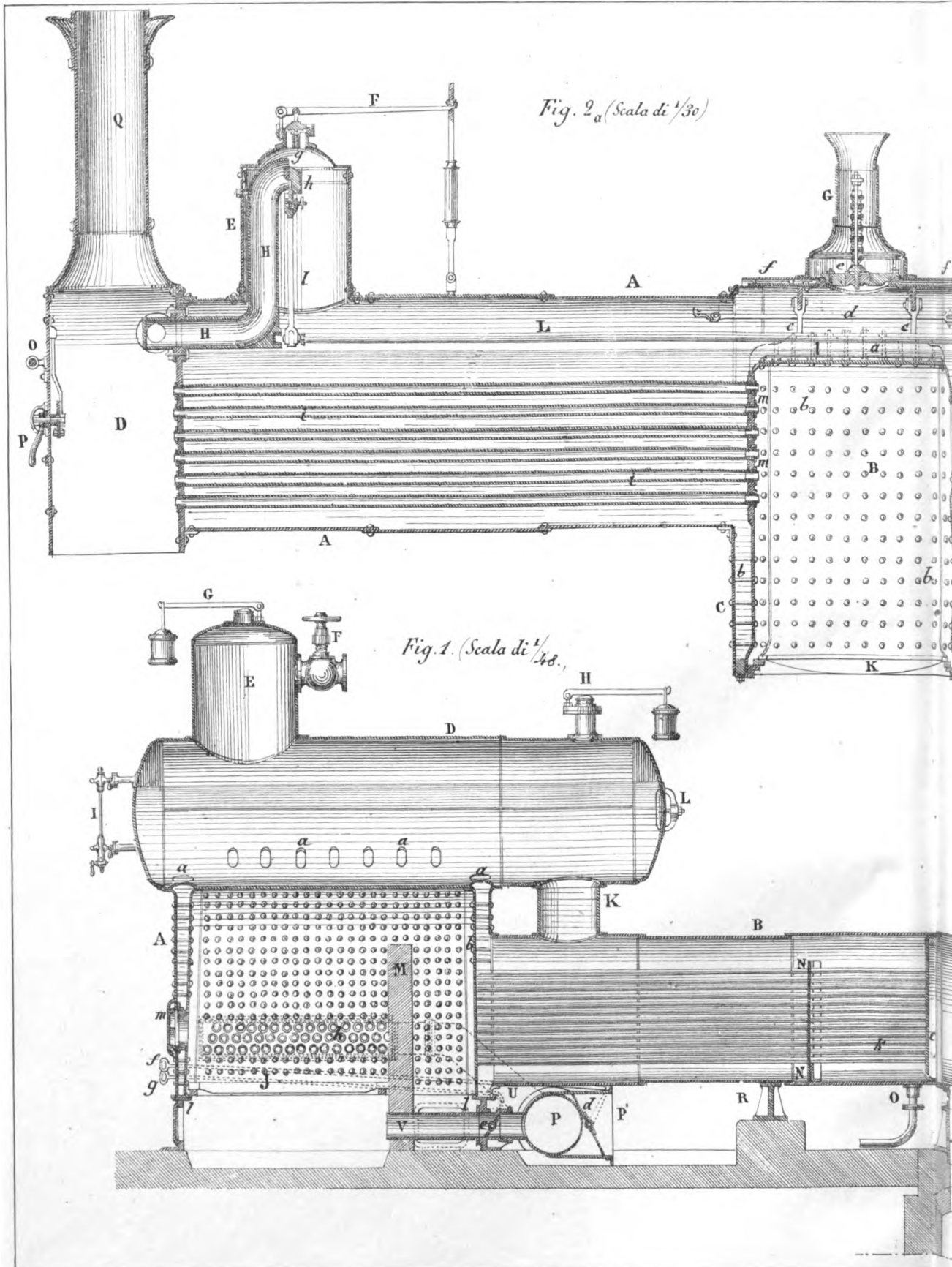

Fig. 2_b (Scala di 1/30)

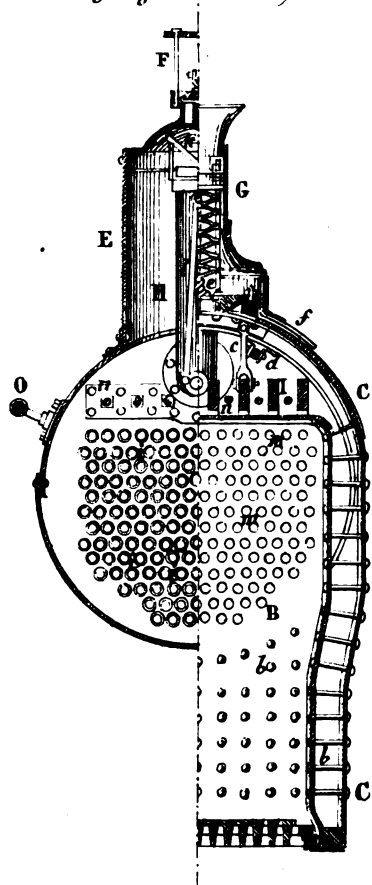

Fig. a (Scala di 1/48)

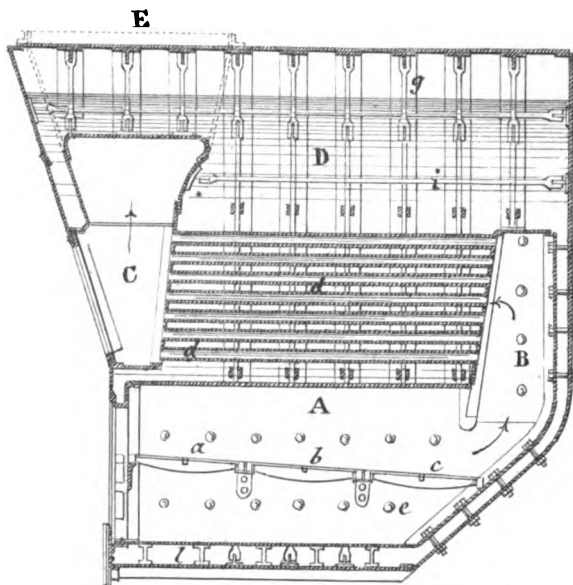
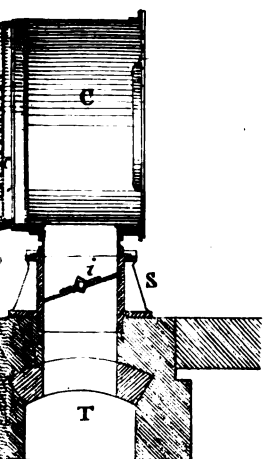
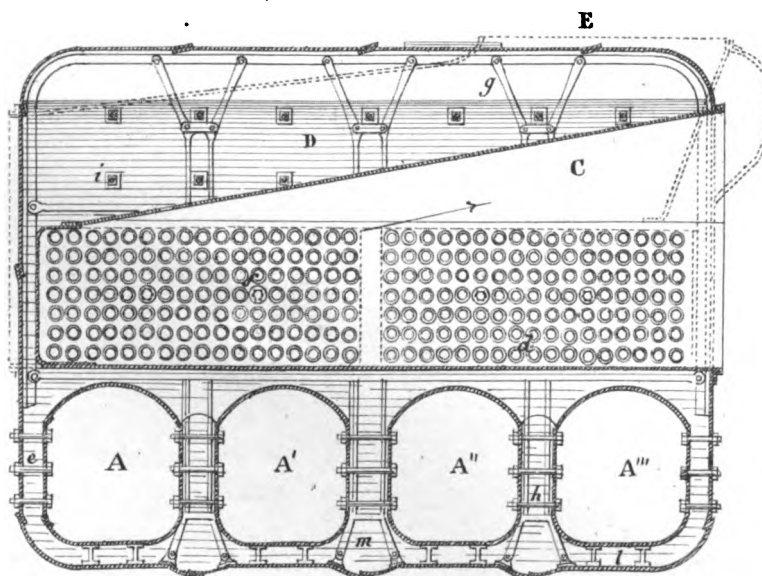

Fig. 3_b (Scala di 1/48)



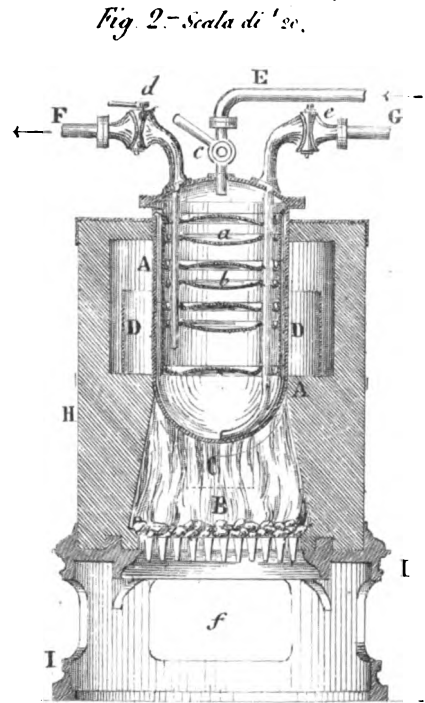
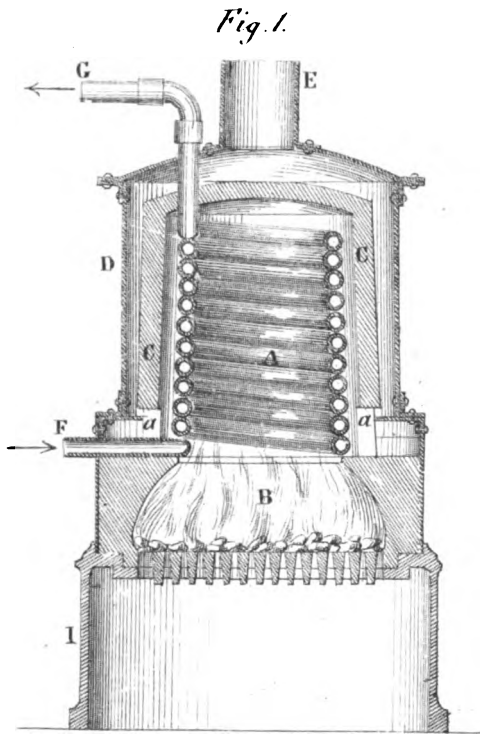

Fig. 3_a - Scala di 1/40.

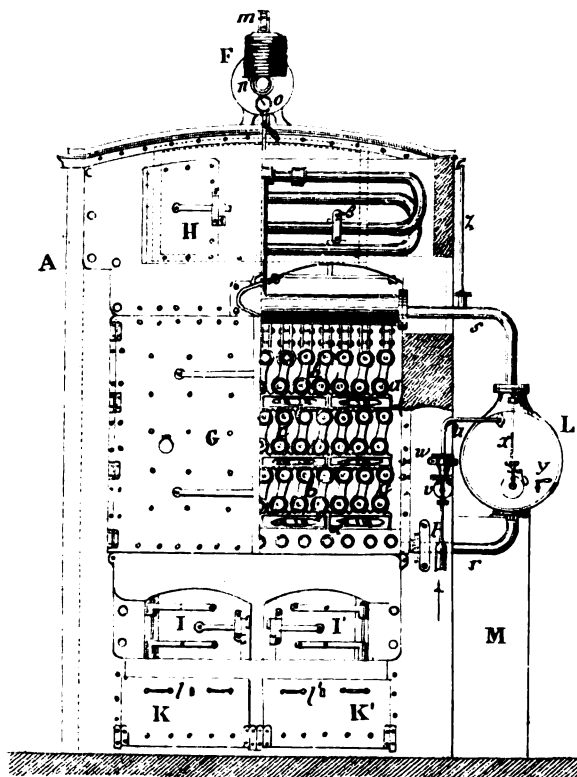

Fig. 3_b - Scala di 1/40.

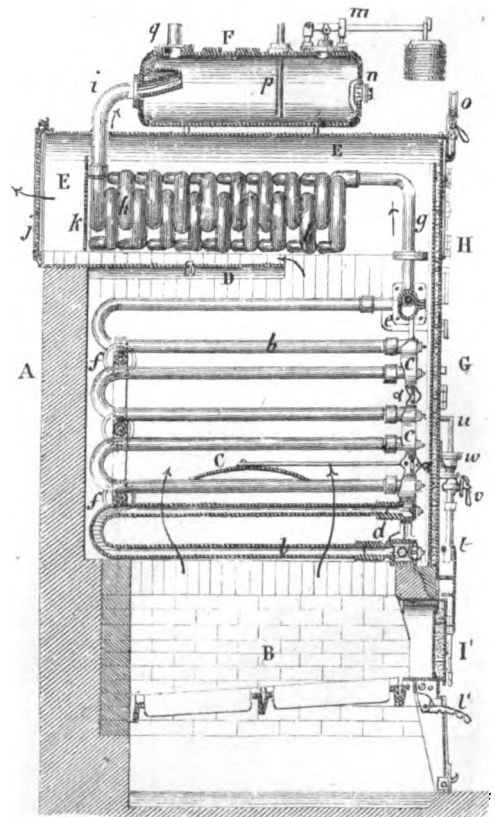

Fig. 5_d - Scala di 1/80.

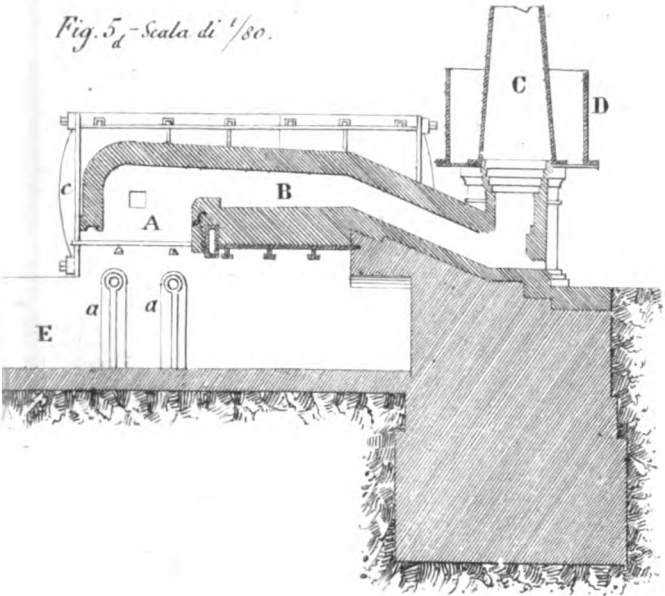

Fig. 5_a - Scala di 1/80

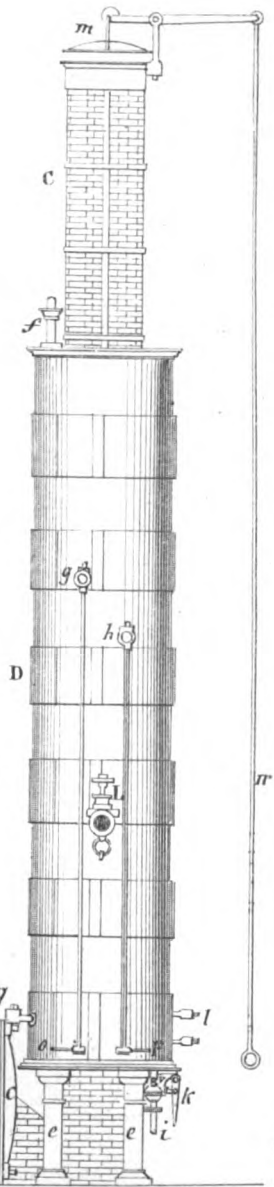

Fig. 5_b - Scala di 1/80.

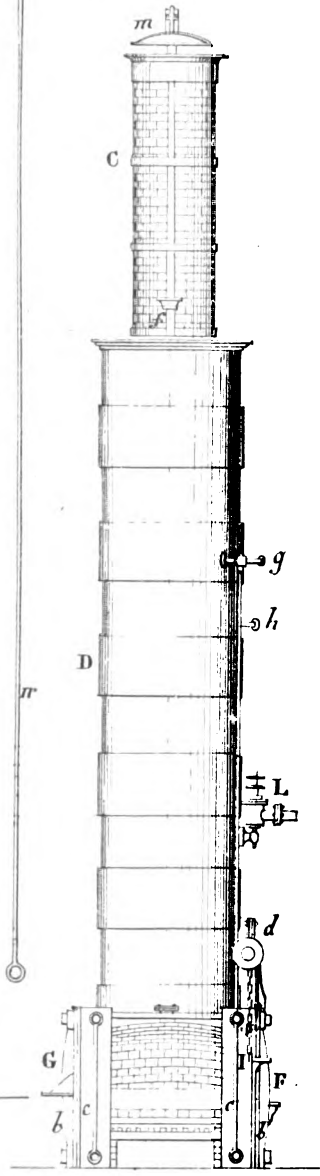

Fig. 4 - Scala di 1/40.

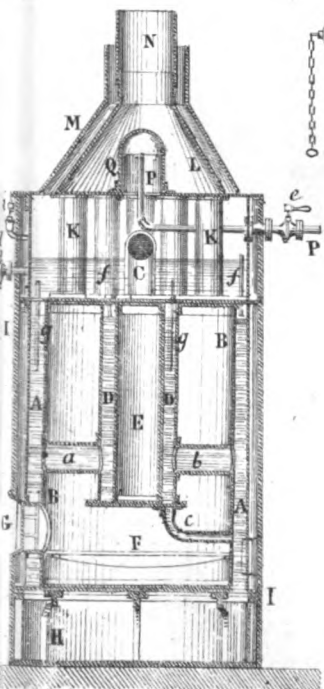
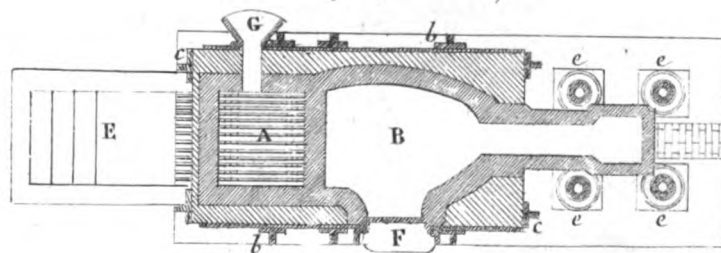
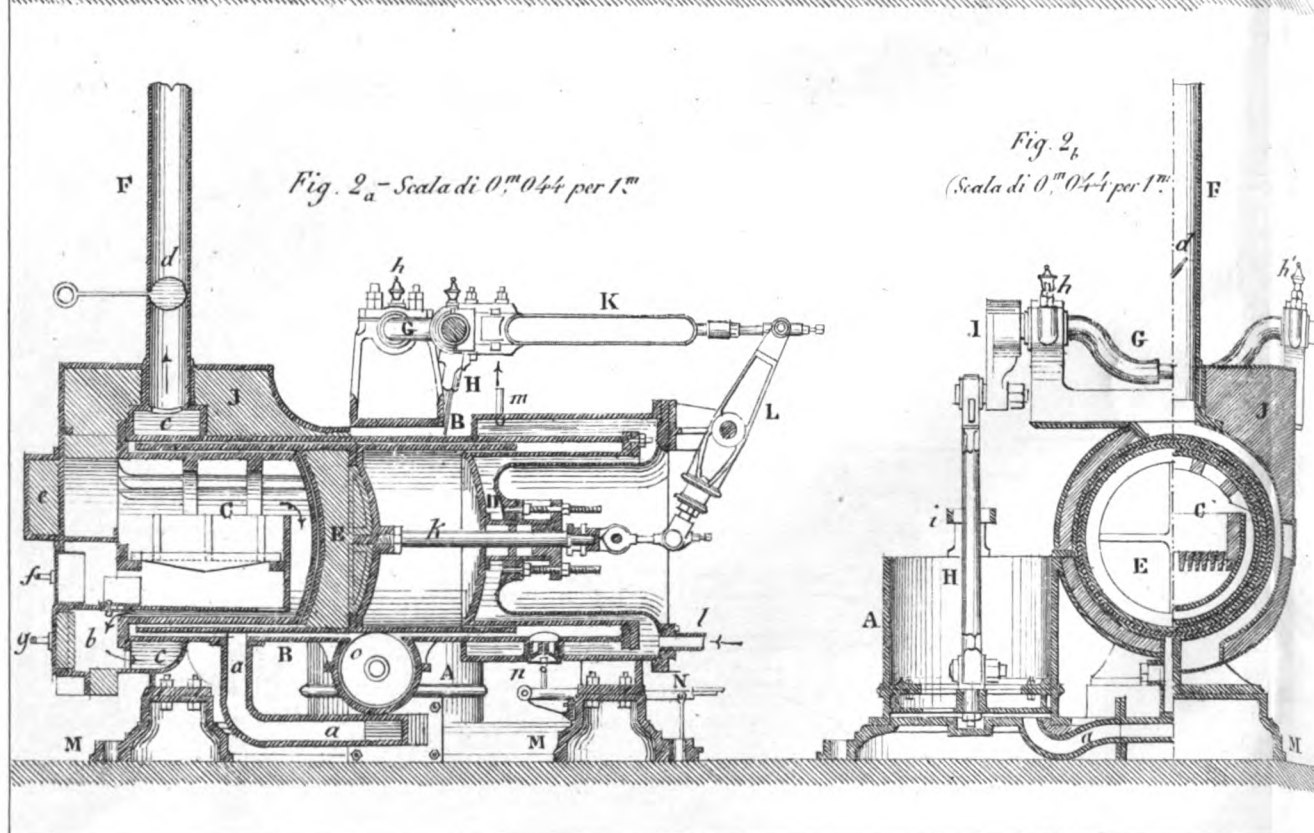
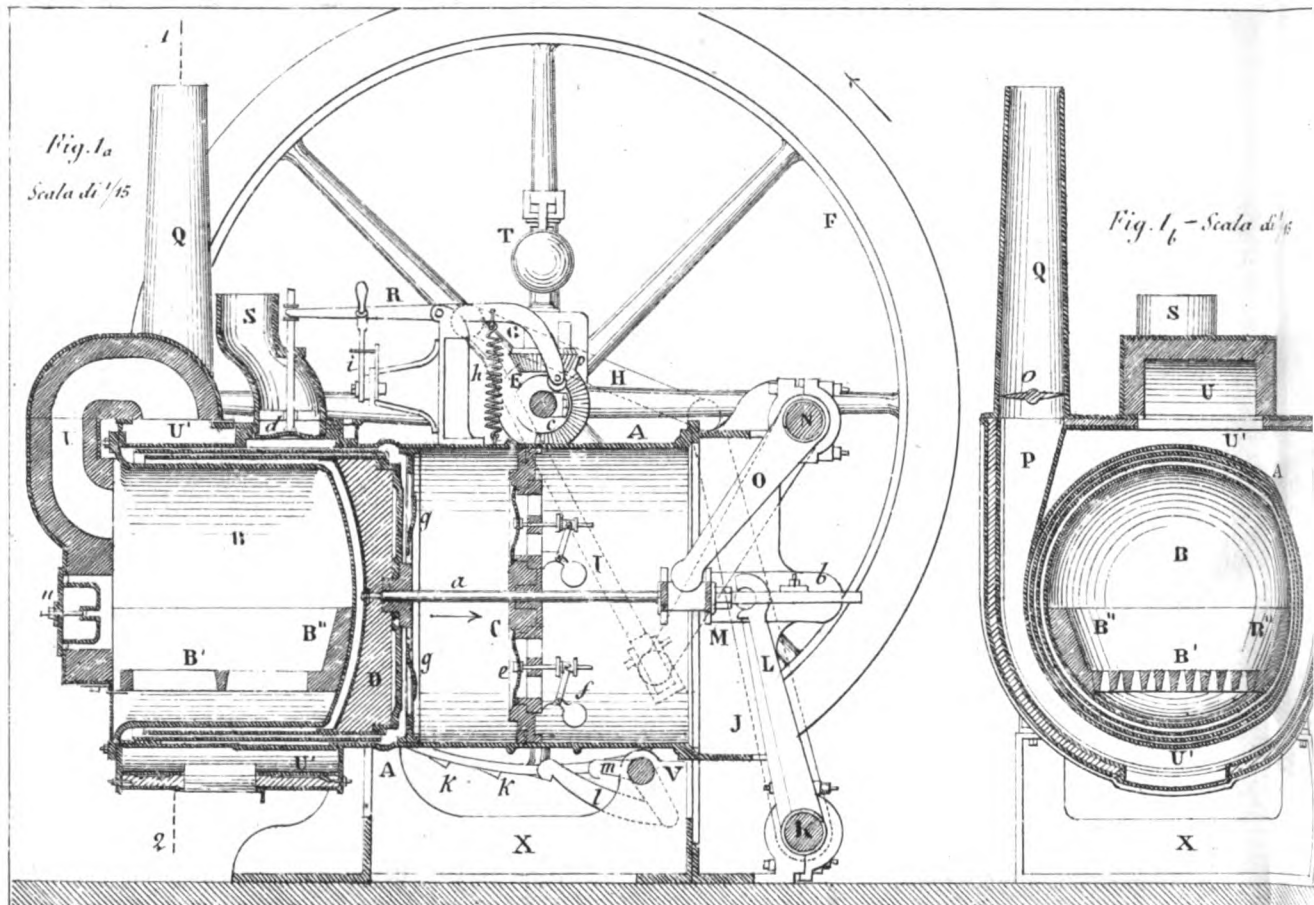

Fig. 5_c - Scala di 1/80.





Federico Serena dis.

Invenzione del Prof. Felice Assoluto

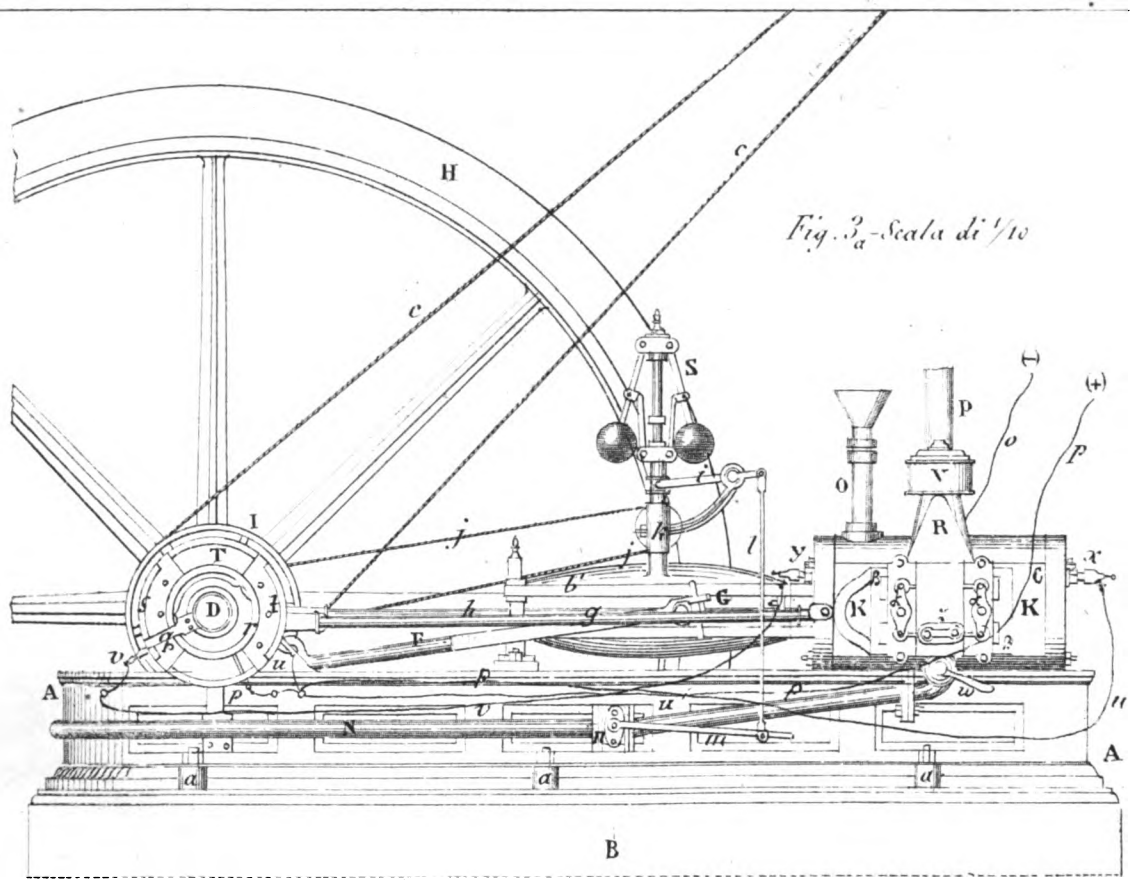

Fig. 3_a - Scala di 1/10



Fig. 3_f - Scala di 1/3.

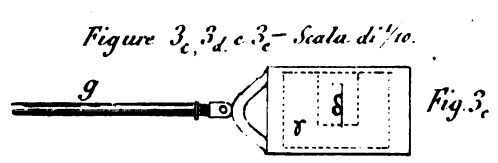

Figure 3_c, 3_d e 3_e - Scala di 1/10.

Fig. 3_c



Fig. 3_d

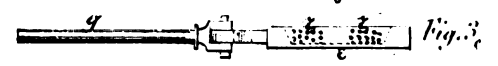
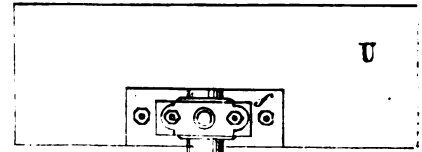
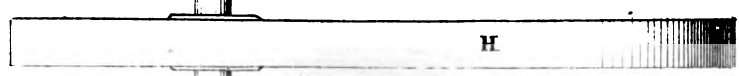

Fig. 3_e



U



H

Fig. 3_g - Scala di 1/10

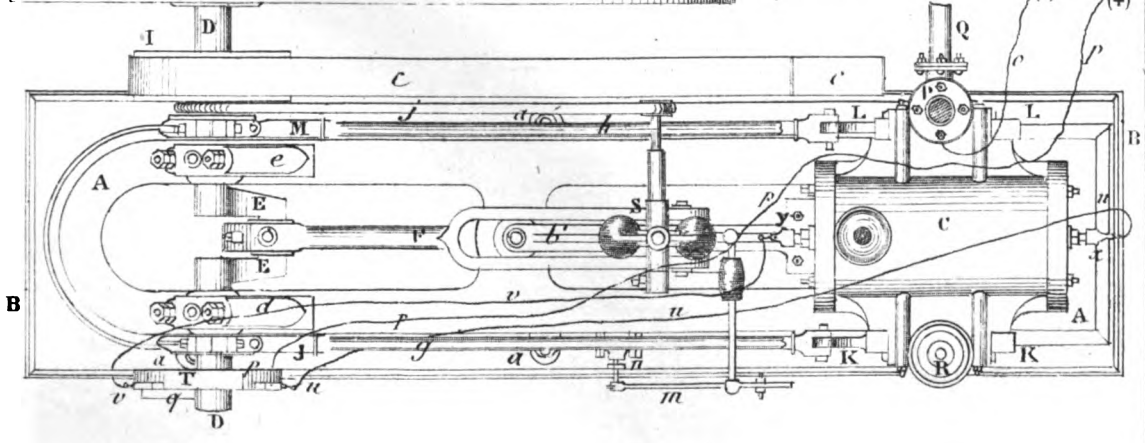

Fig. 3 - Scala di 1/10

Fig. 1_a - Scala di 0,03 per 1"

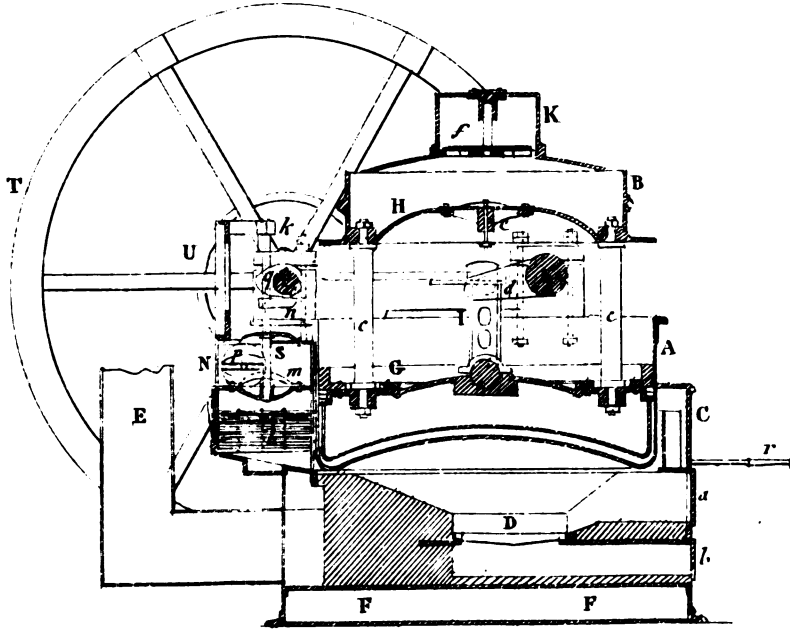

Fig. 3 - Scala di 1/2"

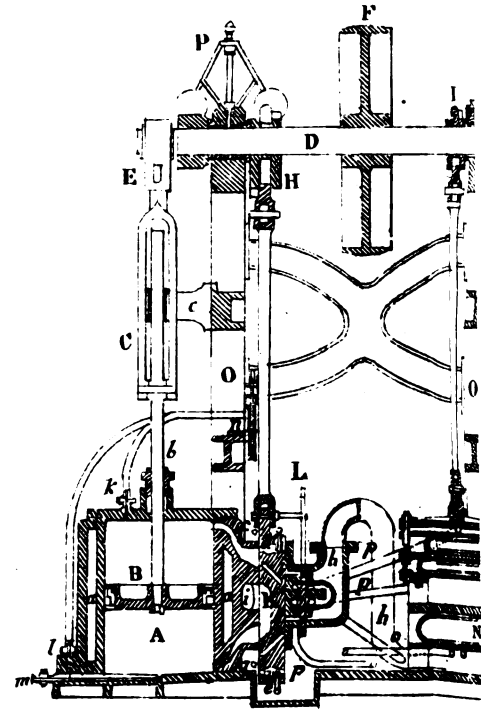

Fig. 1_b - Scala di 0,03 per 1"

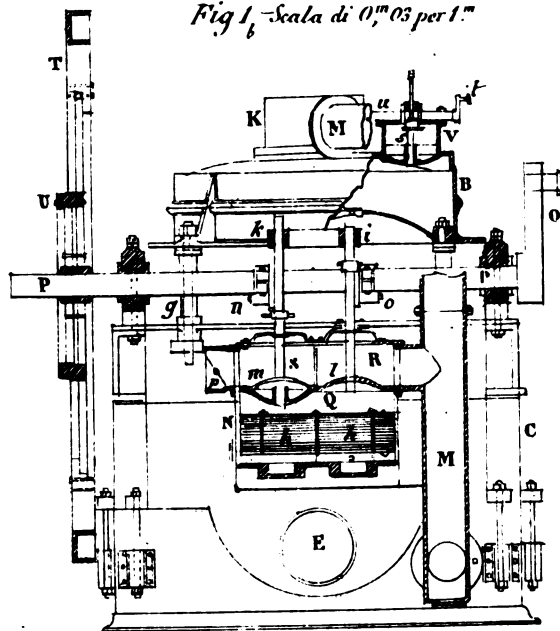
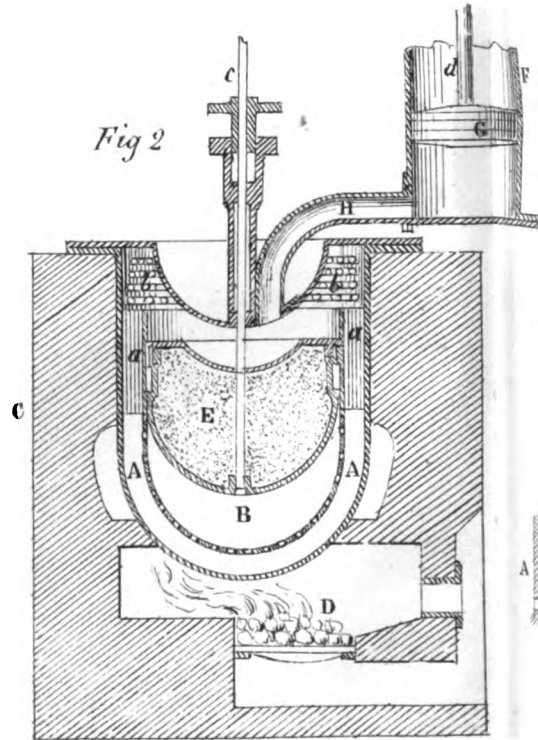
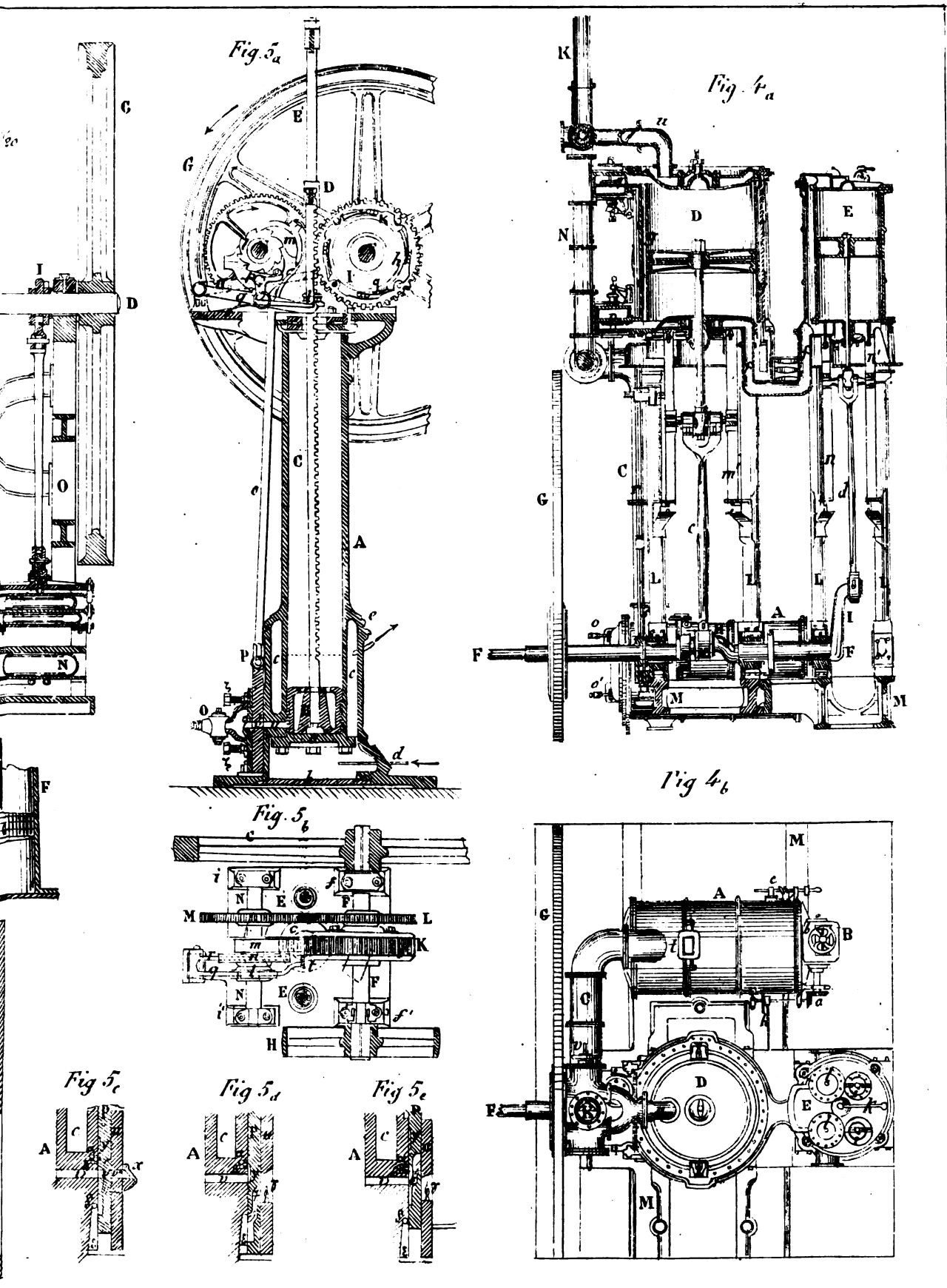
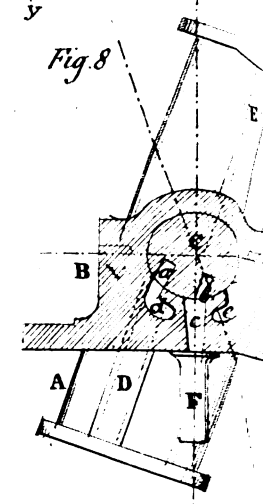
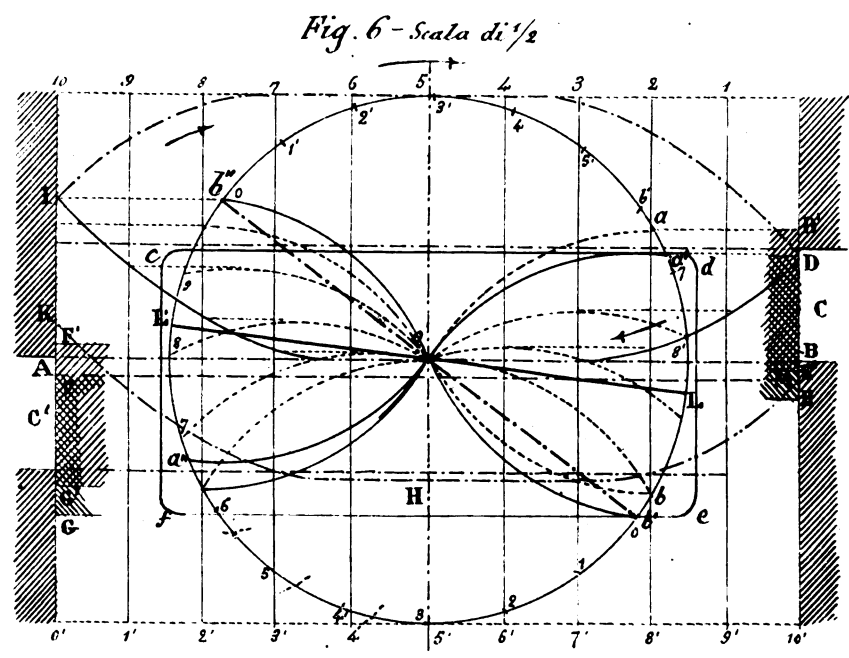
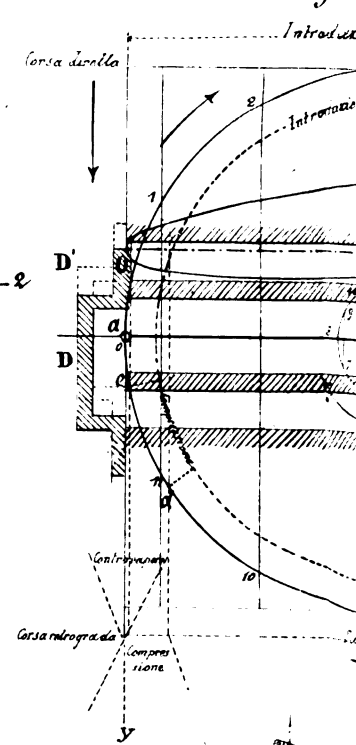
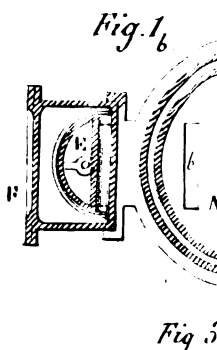
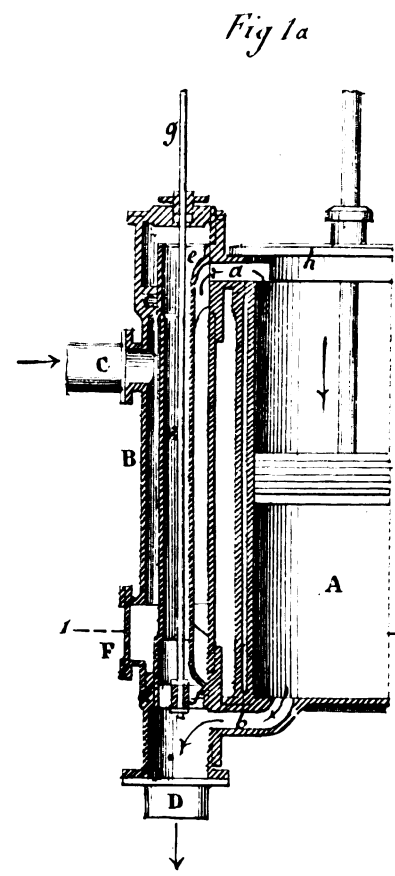
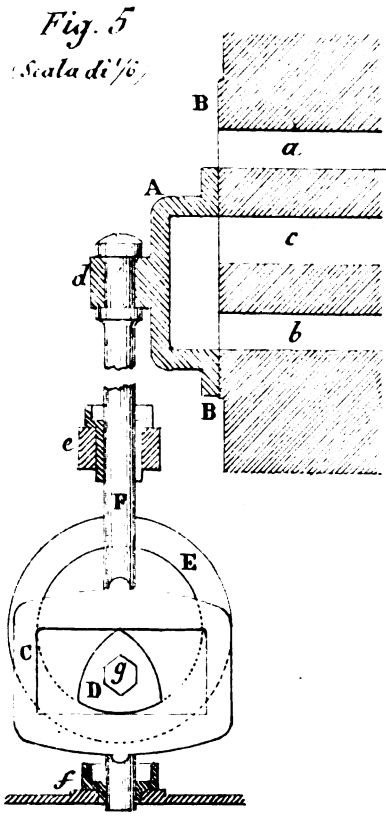

Fig. 2







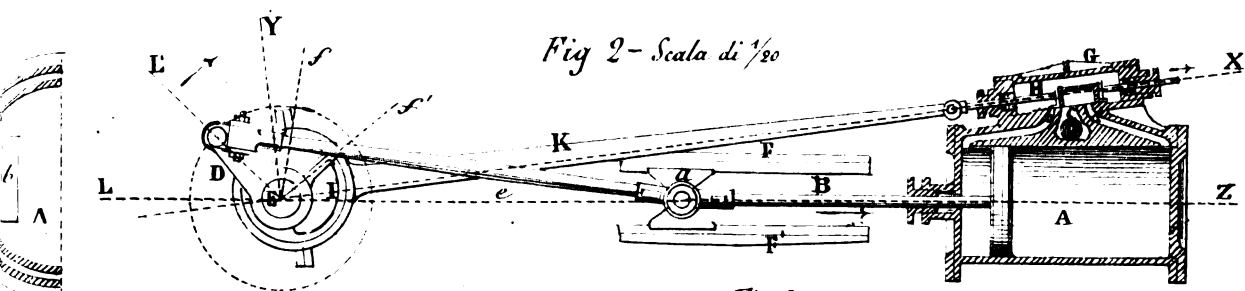

Fig. 3 - Scala di 1/8

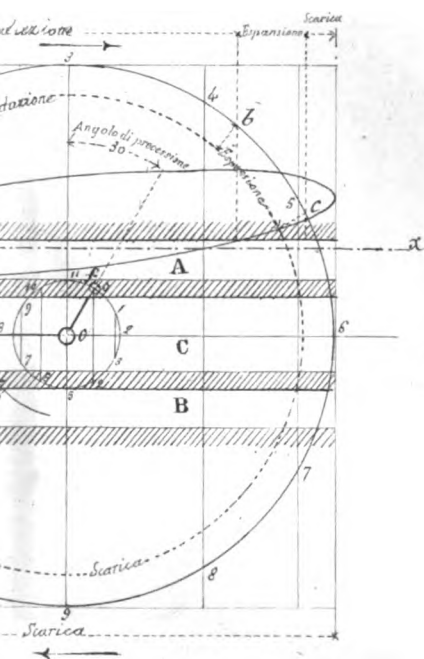

Fig. 4 - Scala di 1/2

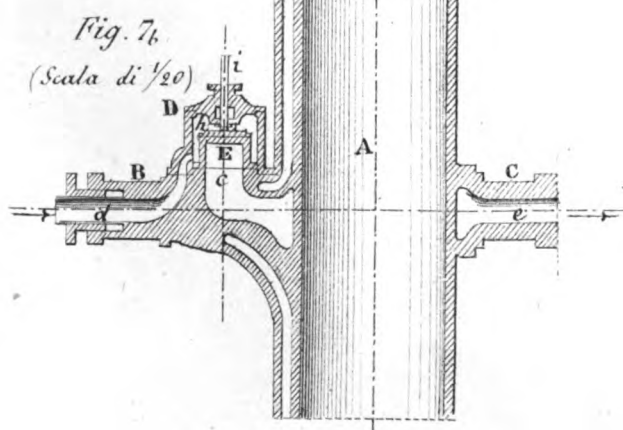
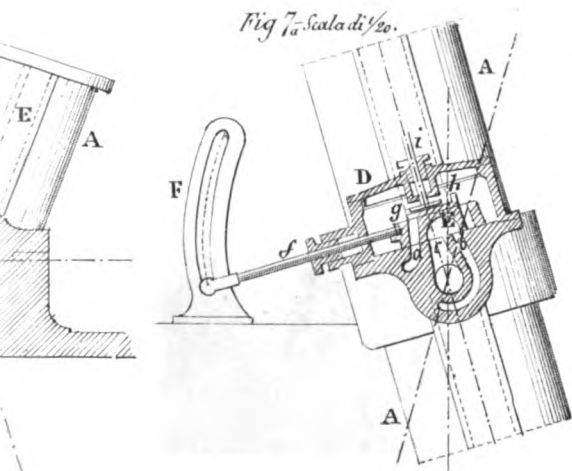
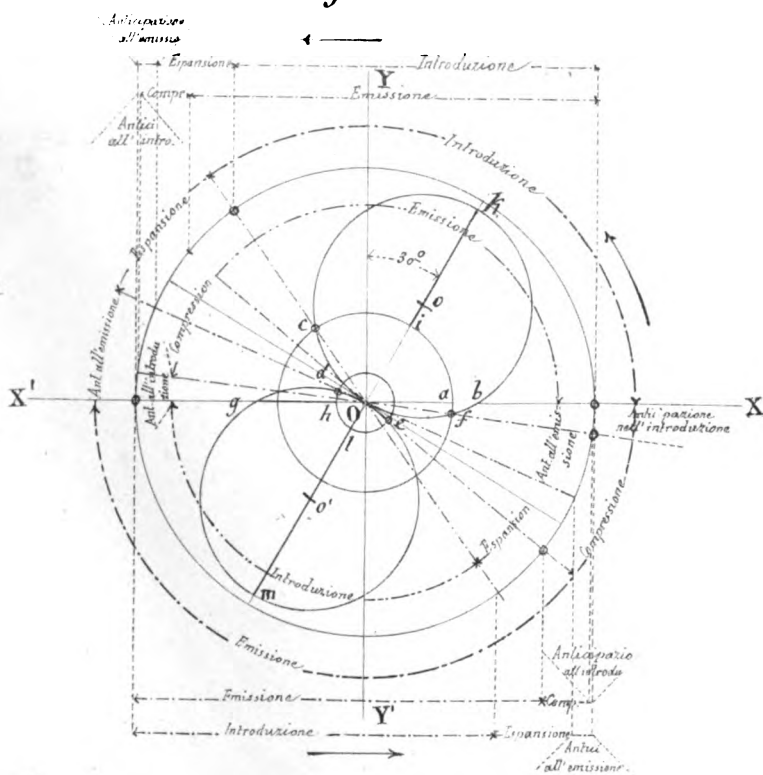

Fig. 1 - Scala di $\frac{1}{6}$

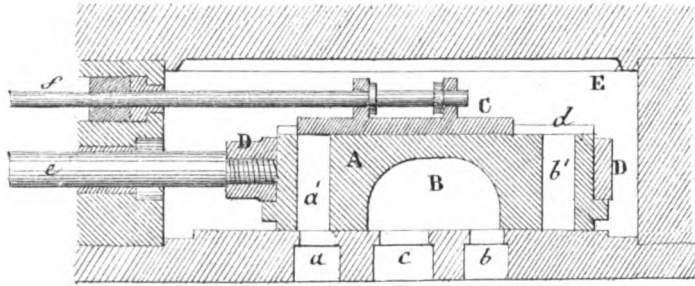

Fig. 3 - Scala di $\frac{1}{6}$

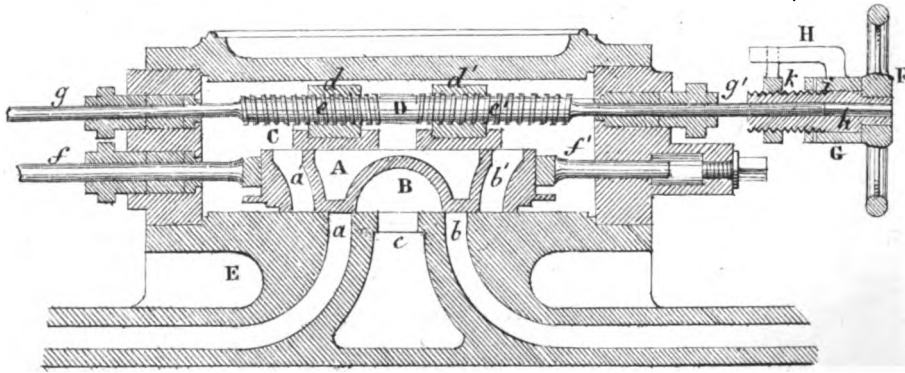

Fig. 5 - Scala di $\frac{1}{6}$

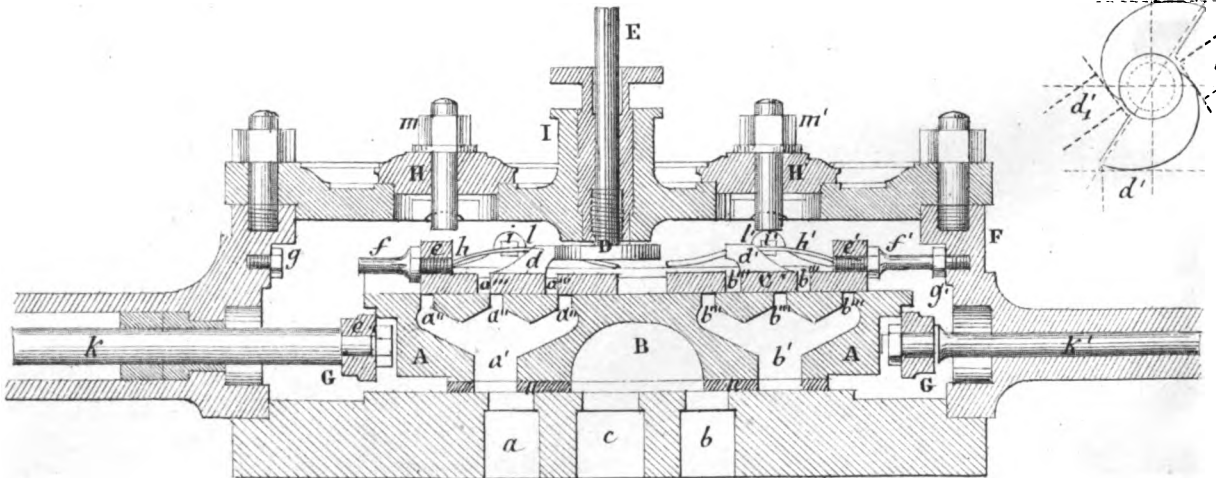

Fig. 2

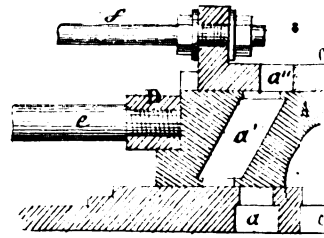

Fig. 6a - Scala di $0^m 282$ per 1^m

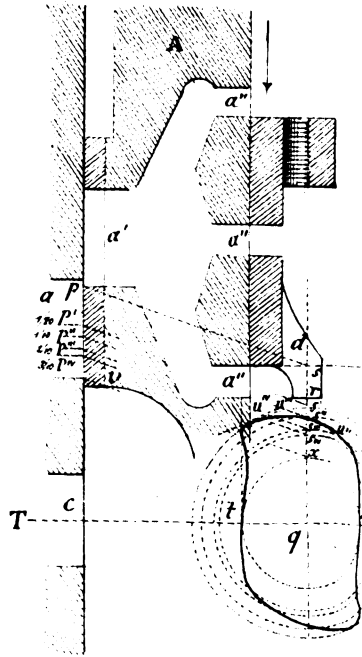

Fig. 6c (Scala di $0^m 282$ per 1^m)

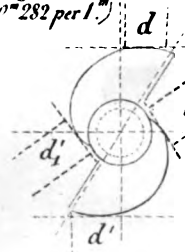

Fig. 2 - Scala di $\frac{1}{6}$

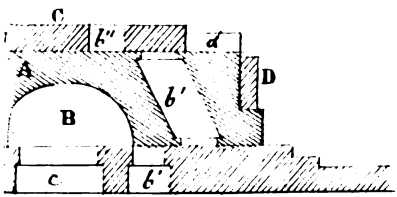

Fig. 4 - Scala di $\frac{1}{8}$

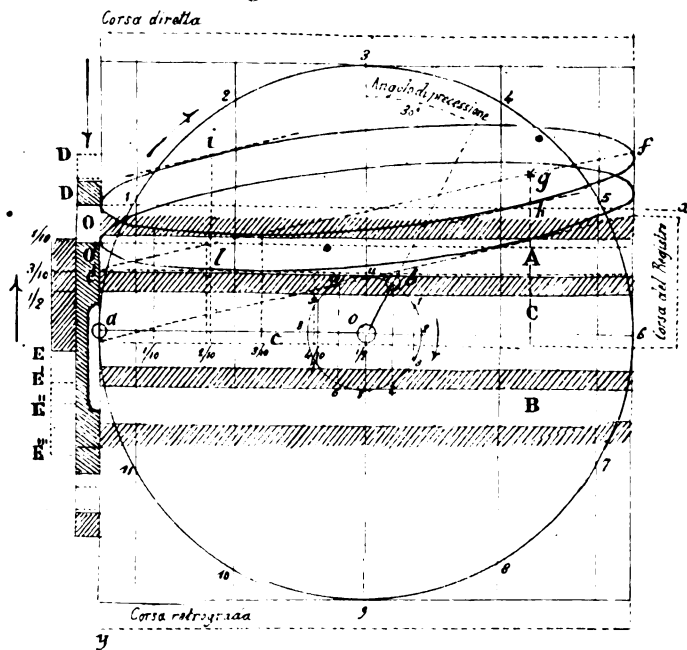

Fig. 6 - Scala di 0.^m 282 per l.^m

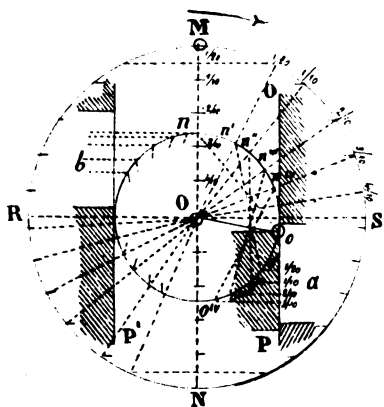

Fig. 8a

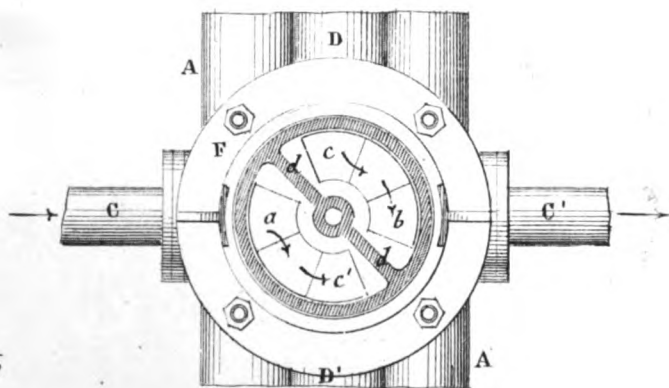

Fig. 7a

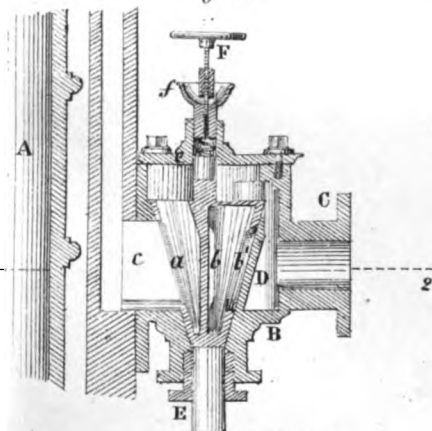

Fig. 8b

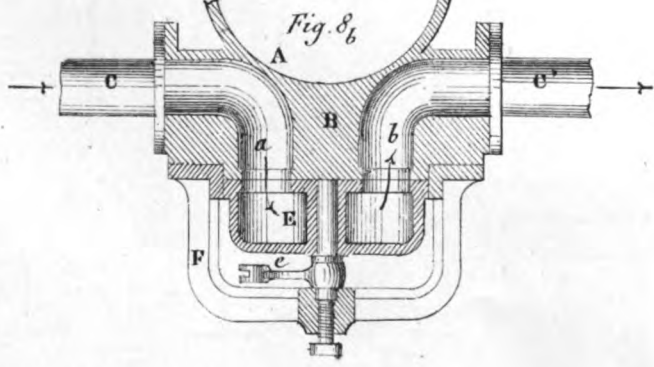
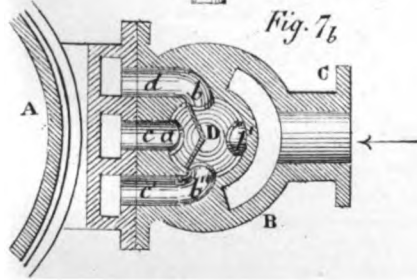
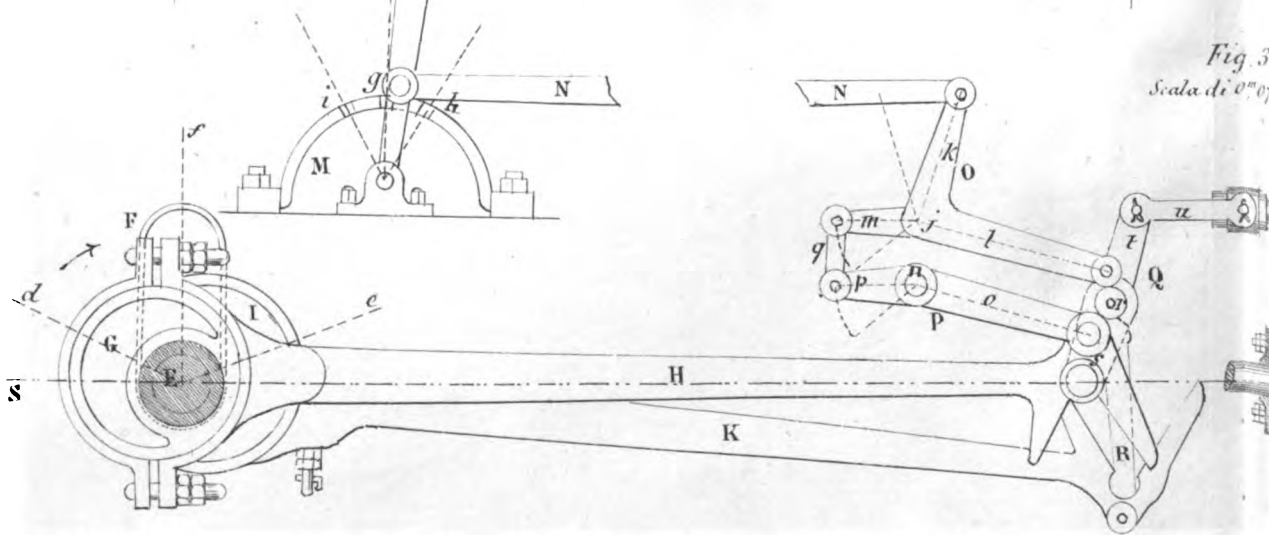
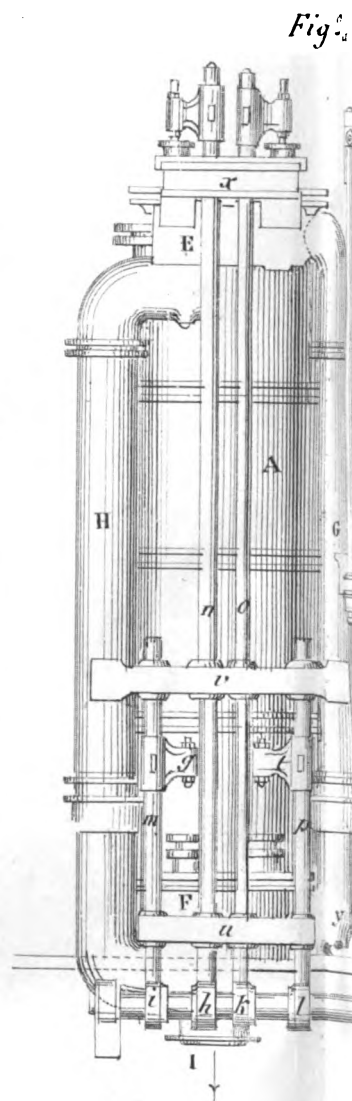
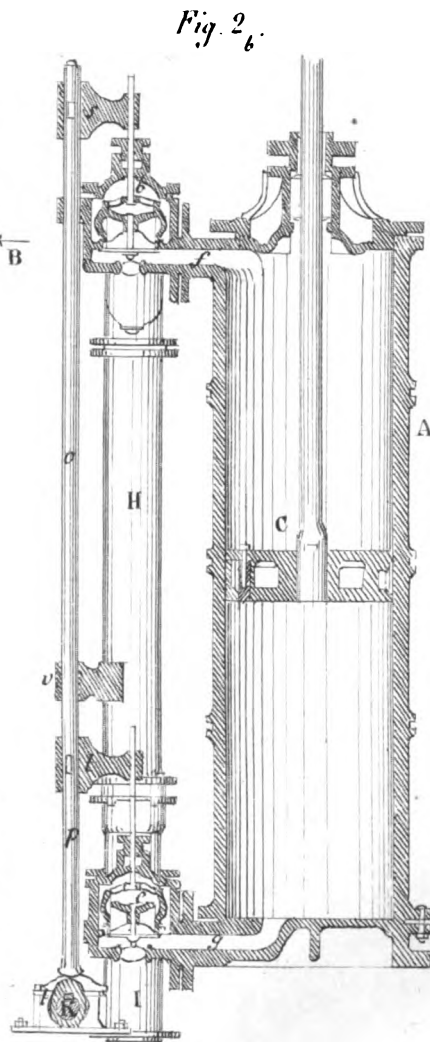
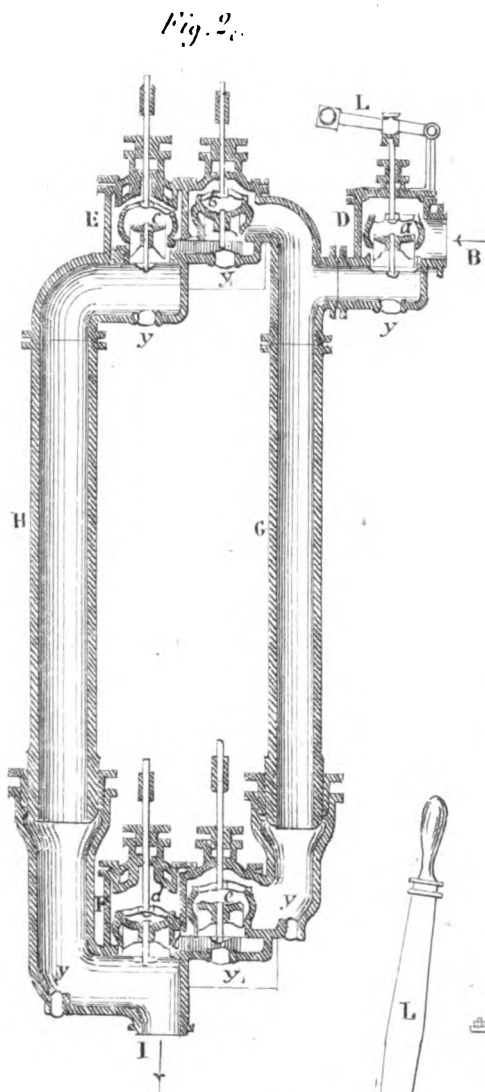
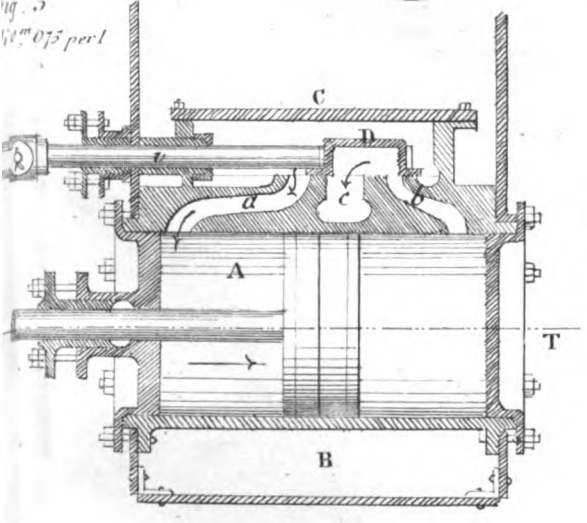
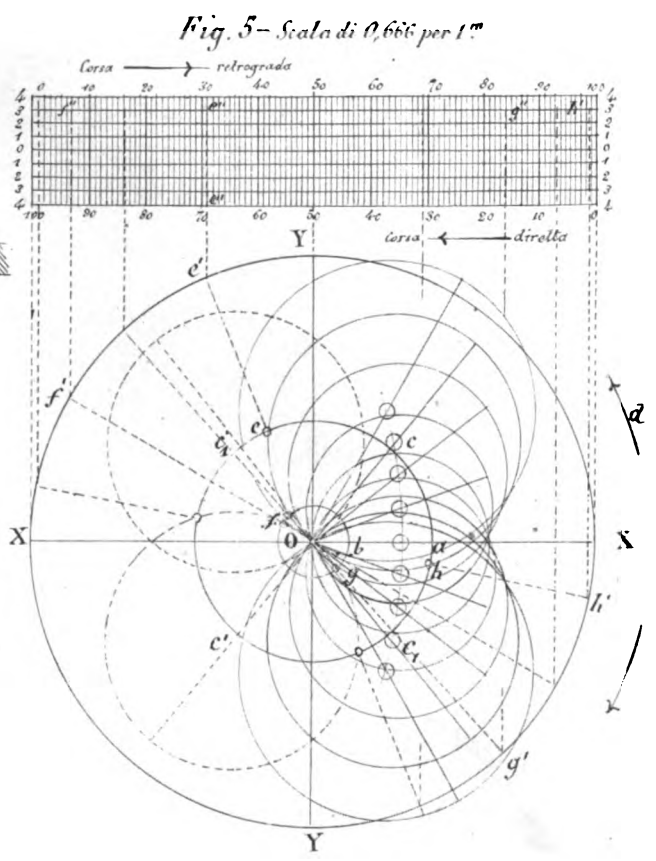
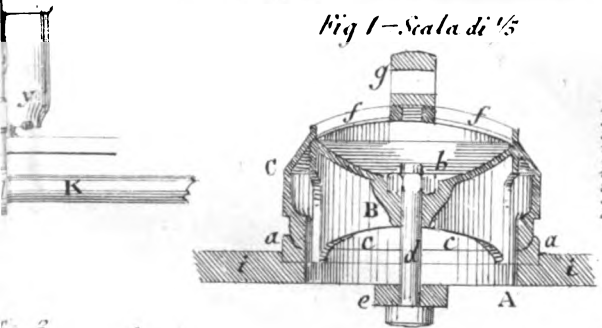
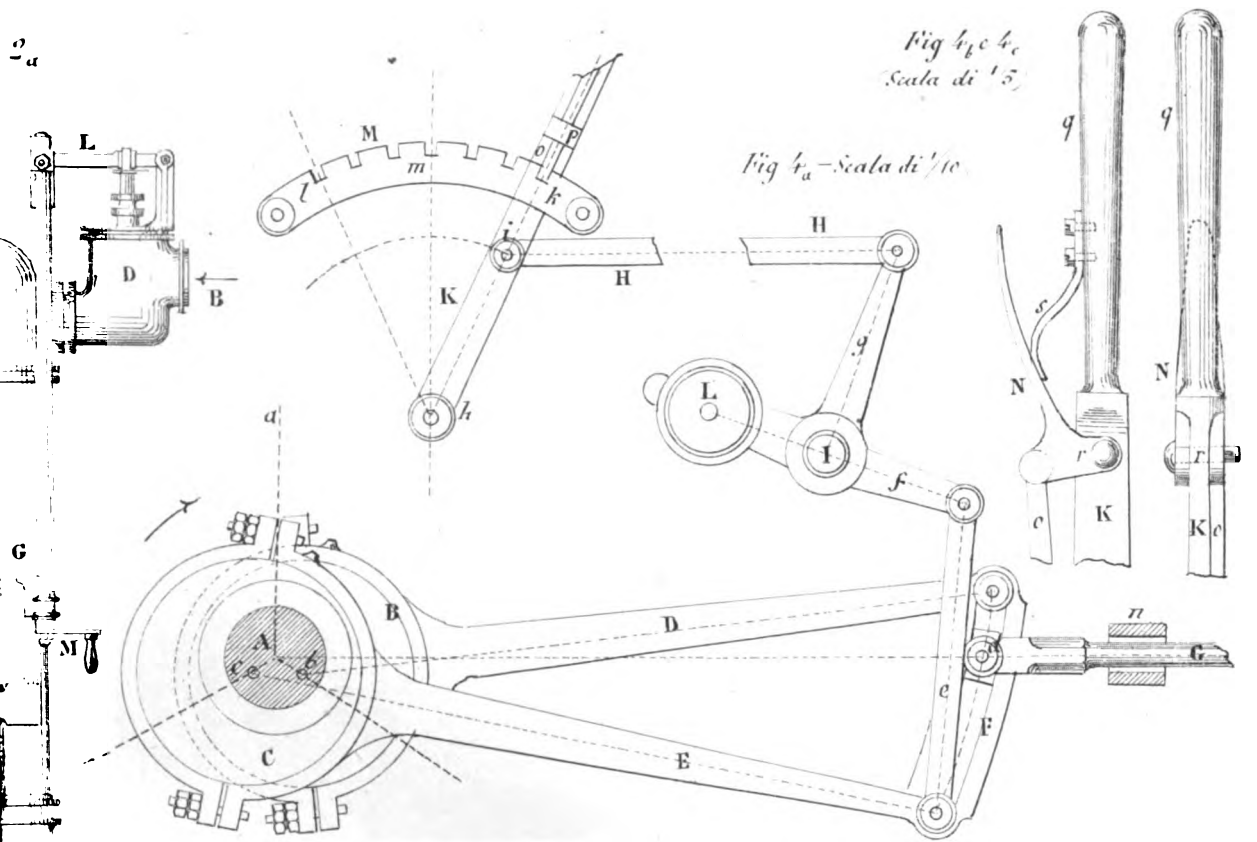
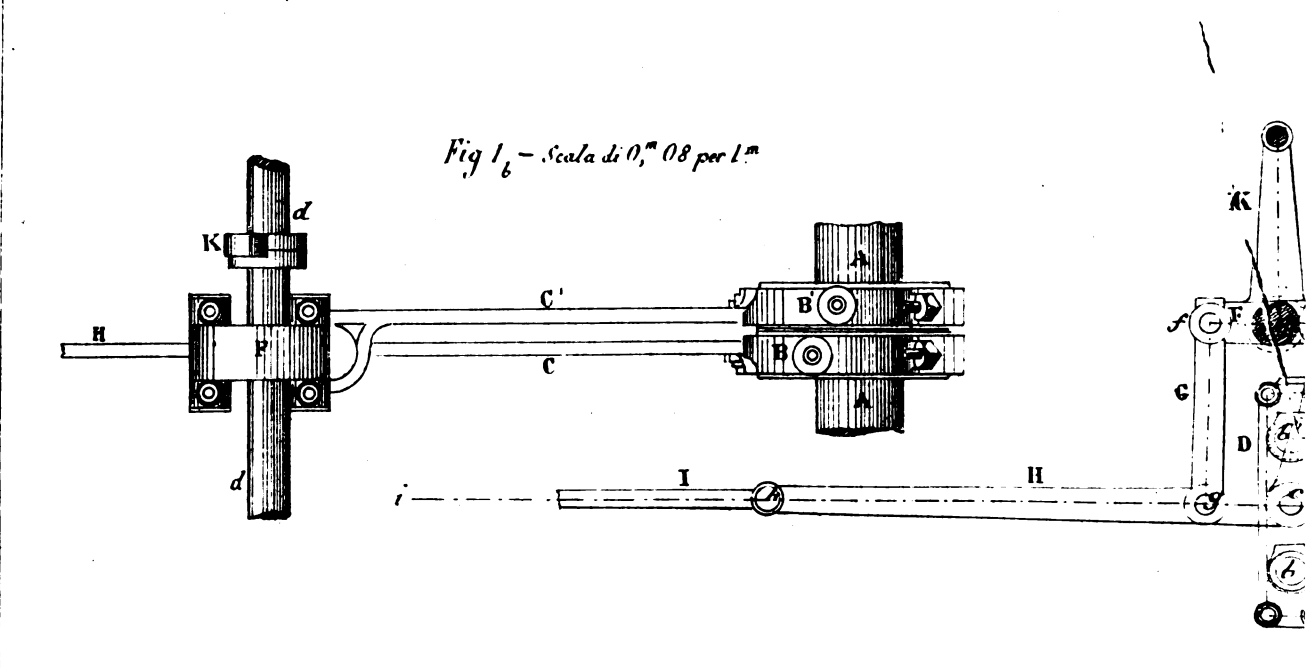
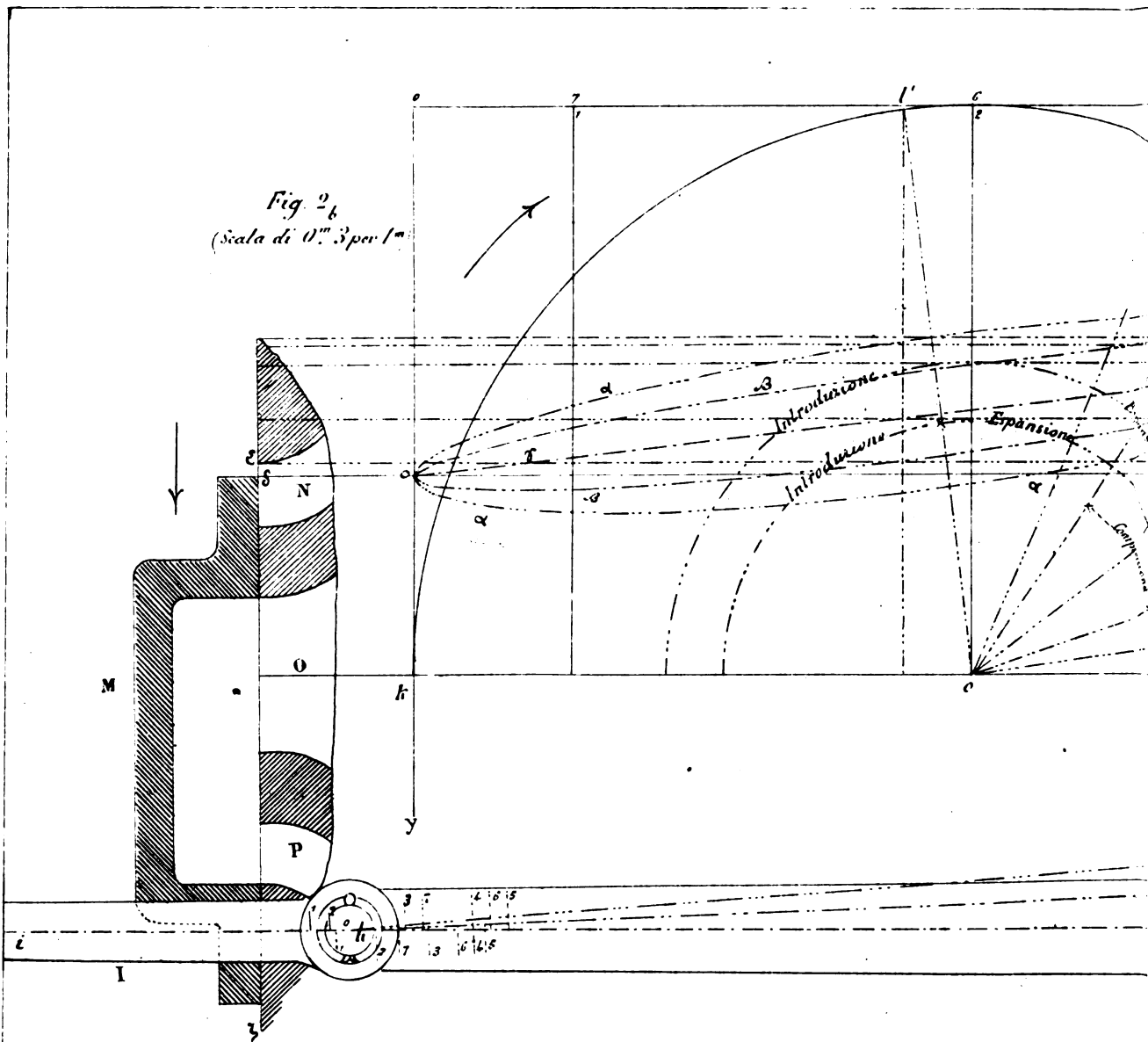

Fig. 7b









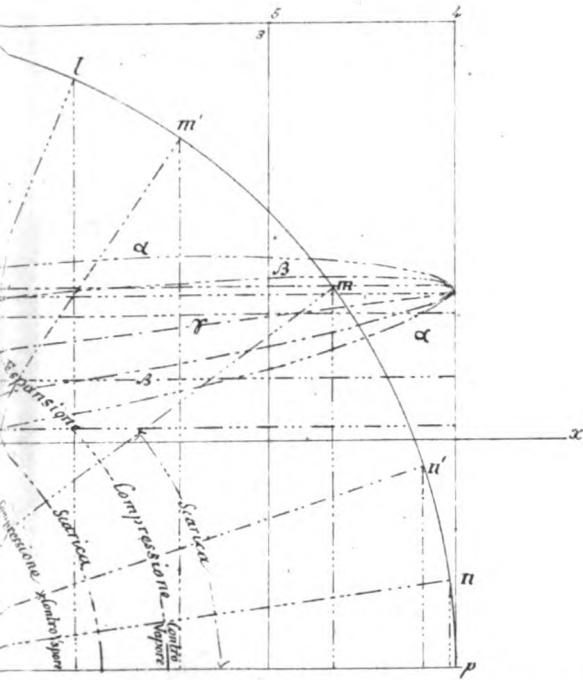
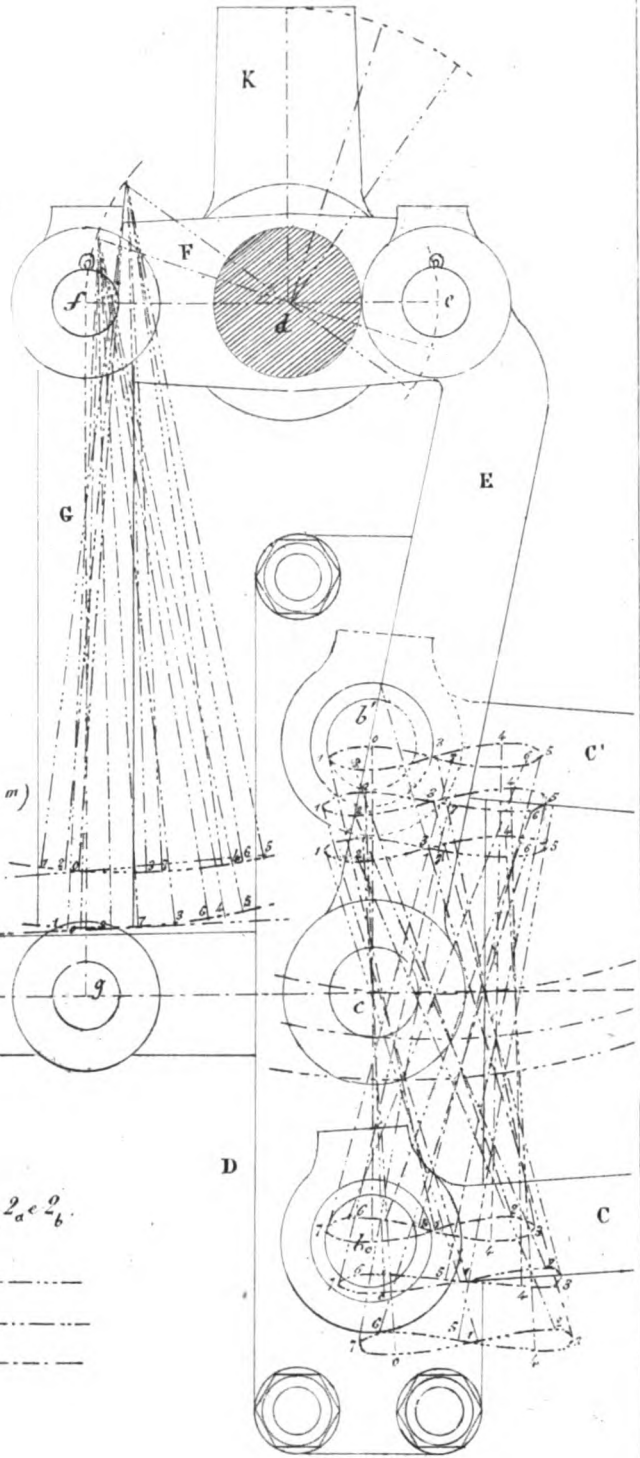

Fig. 2a
(Scala di 0^m 3 per 1^m)



Segni convenzionali per le figure 2_a e 2_b.

- Corsa massima ————
- Corsa media ————
- Punto morto ————

Fig. 1_a - Scala di 0^m 08 per 1^m

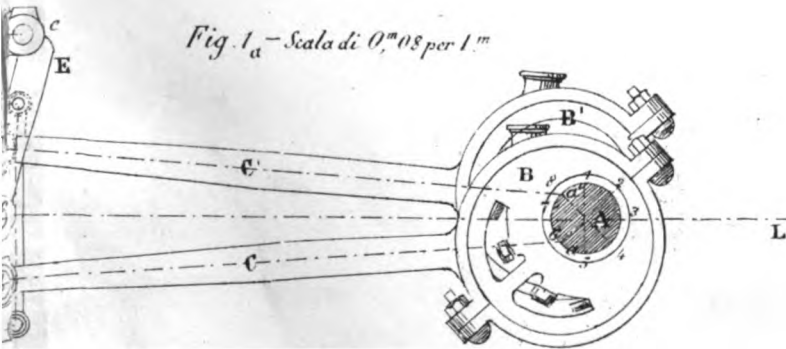

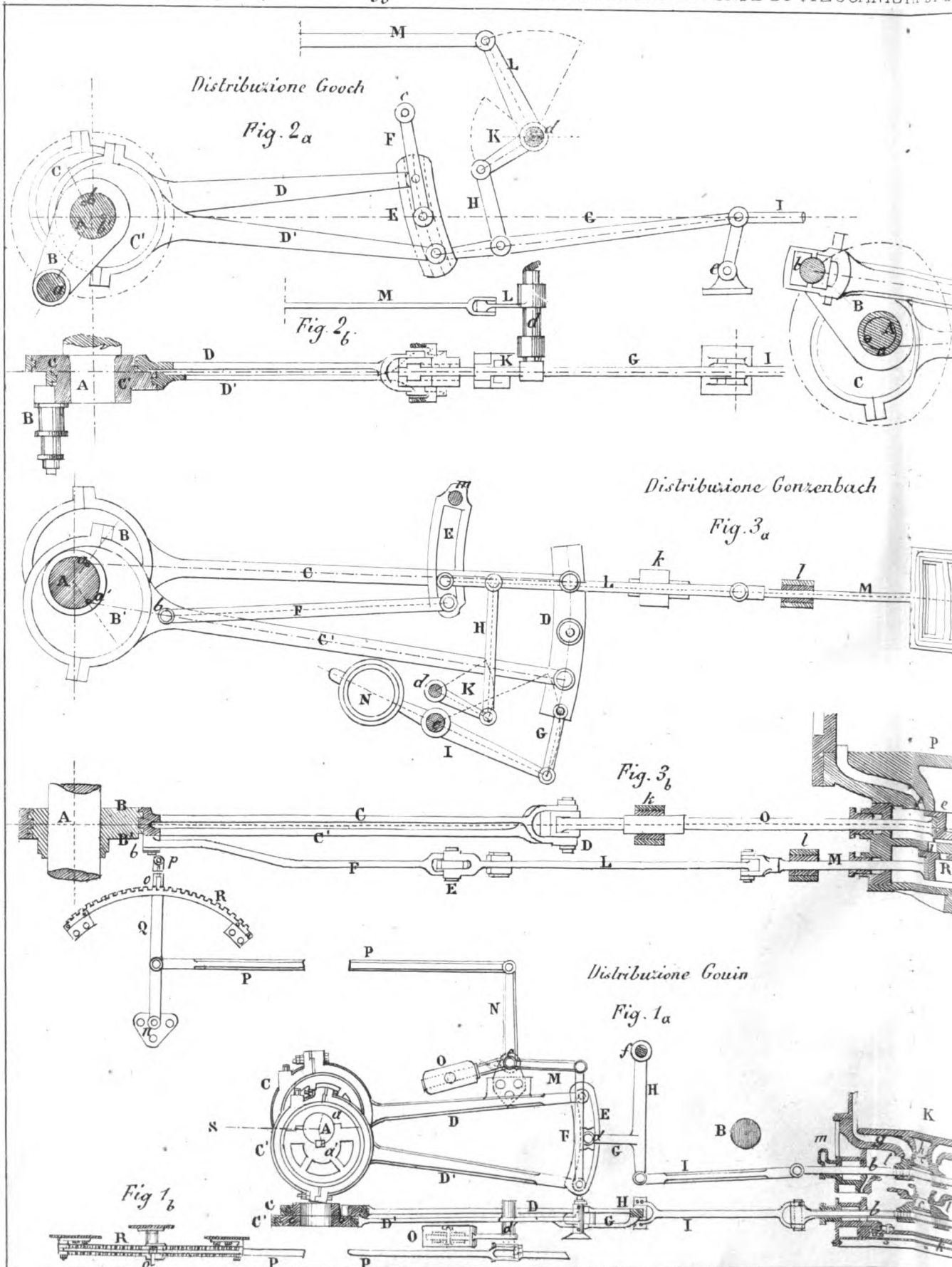

Distribuzione Heusinger di Waldegg

Fig. 4.

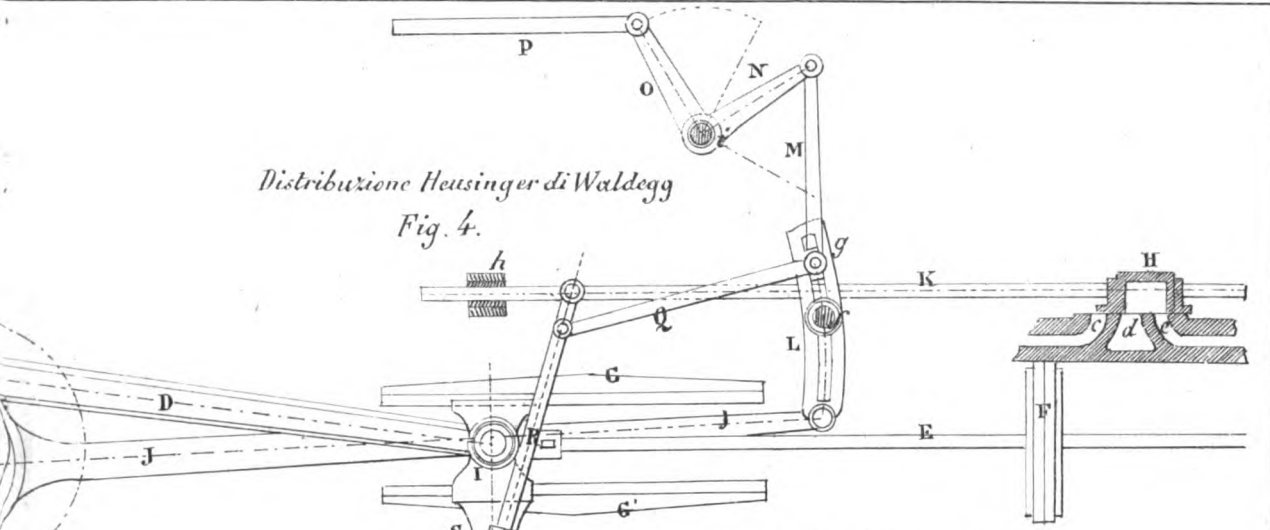

Distribuzione Polonceau

Fig. 5_b

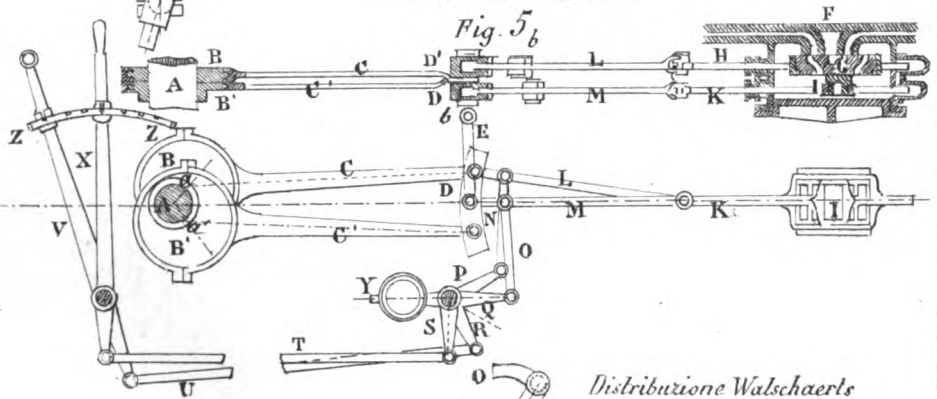

Distribuzione Walschaerts

Fig. 6_a - Scala di 1/20

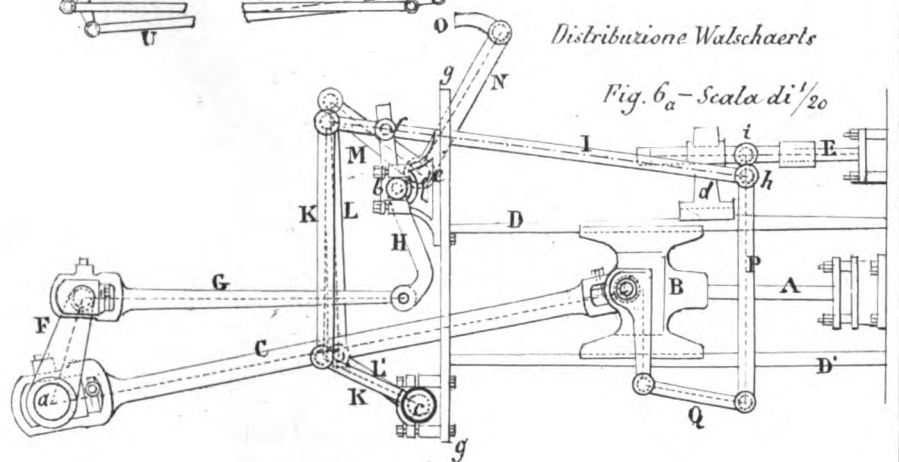
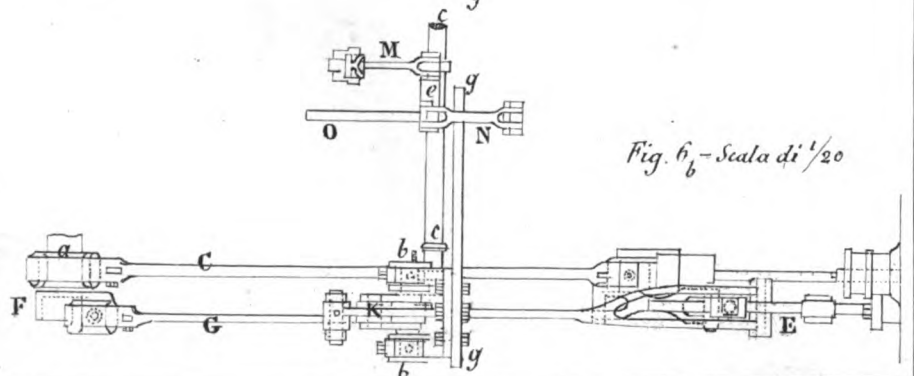
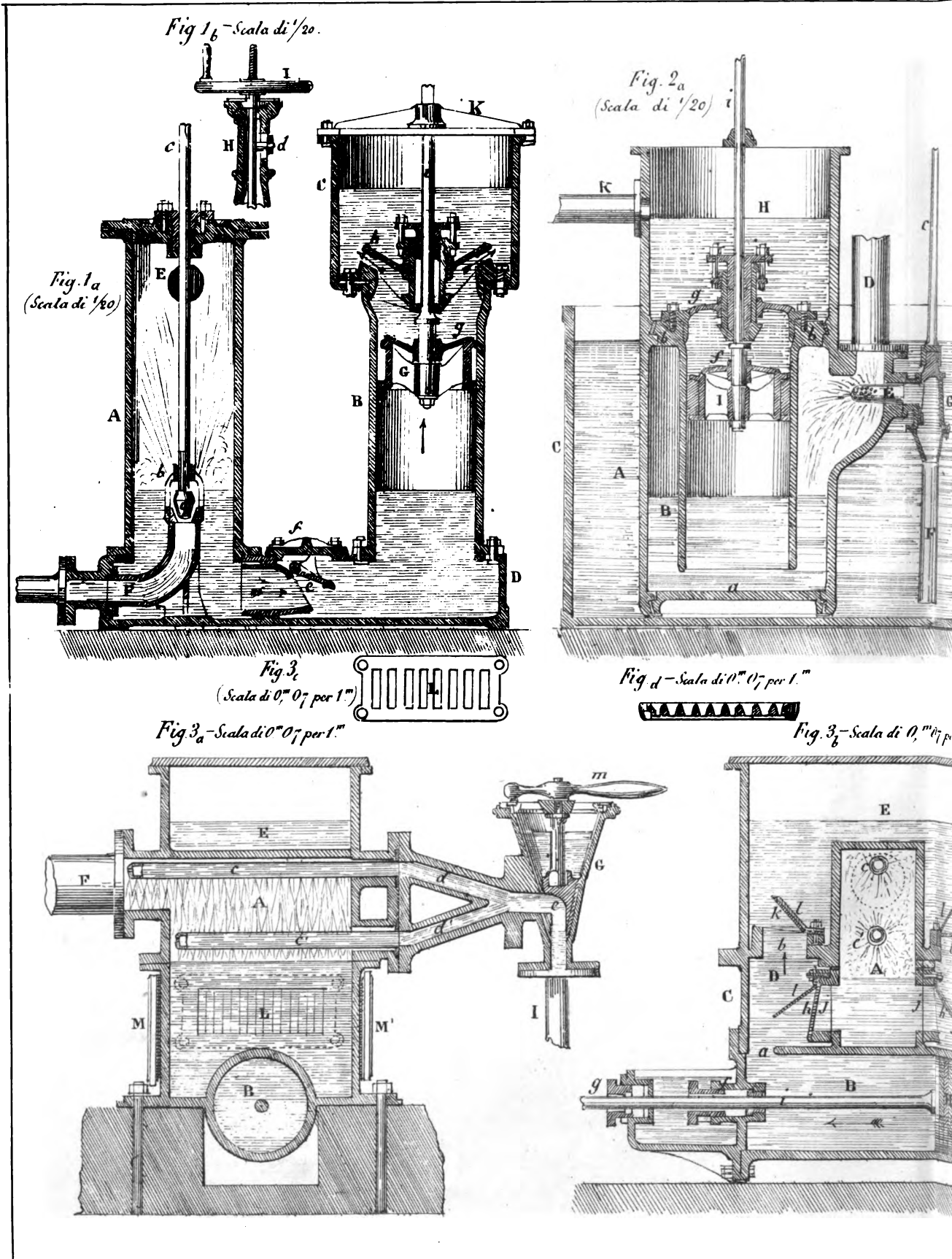

Fig. 6_b - Scala di 1/20





Vandelli Anacleto dis.

torino lit. P. Broja Via S. L.

Fig. 2. Scala di 1/20

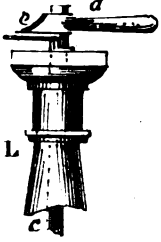

Fig. 4
(Scala di 0,07 per 1.^m)

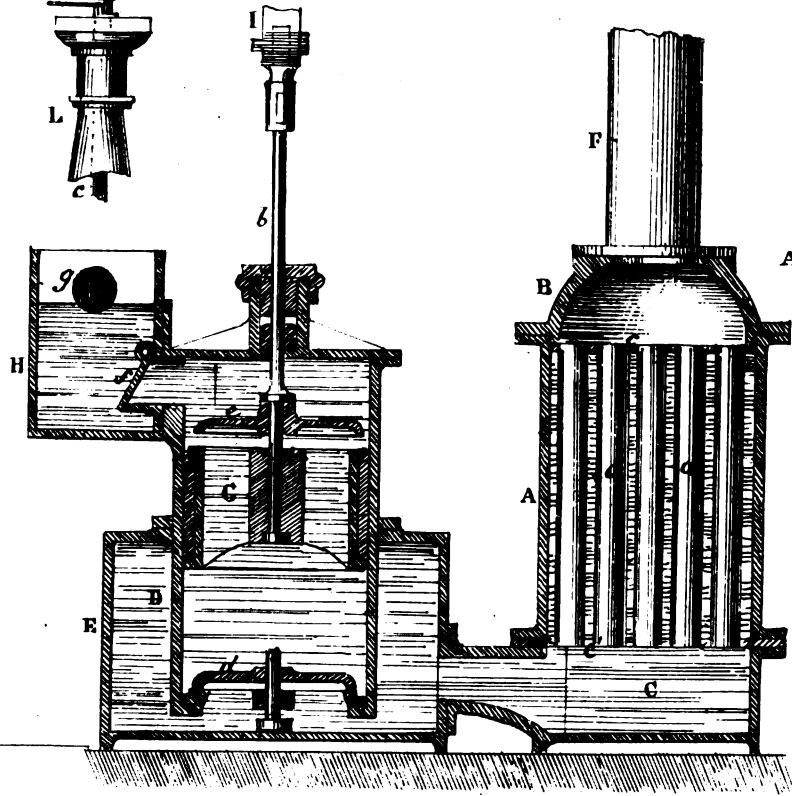
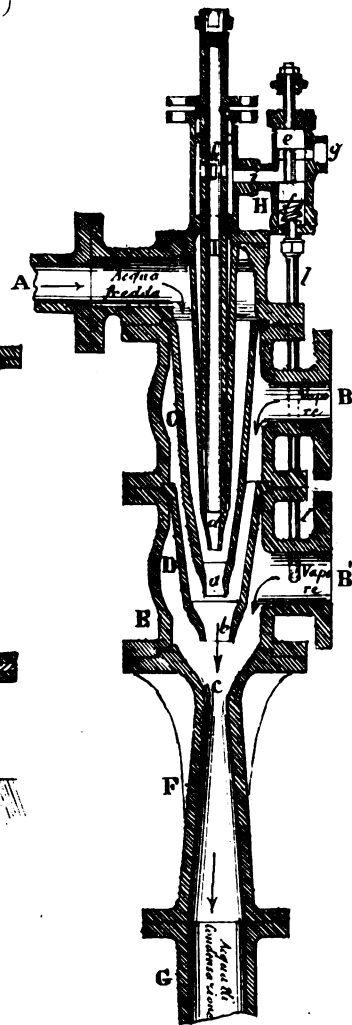

Fig. 7. Scala di 1/10



07 per 1.^m

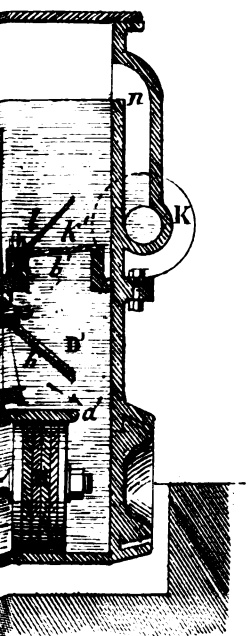

Fig. 5

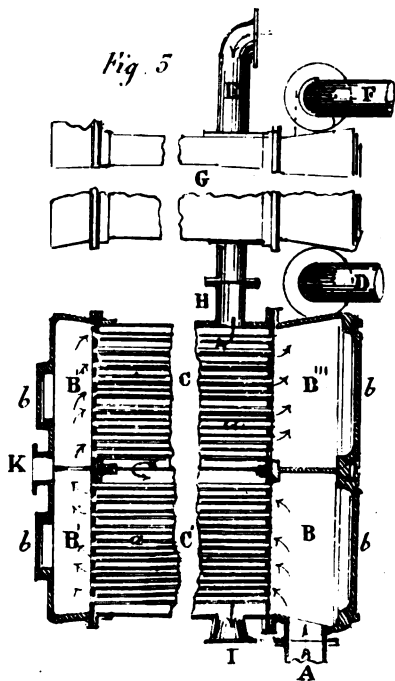
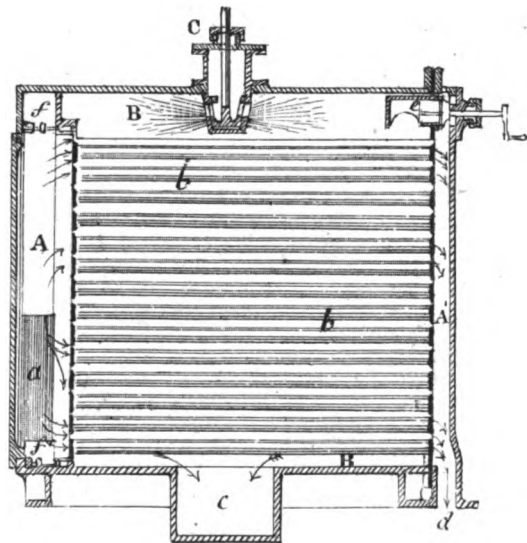

Fig. 6



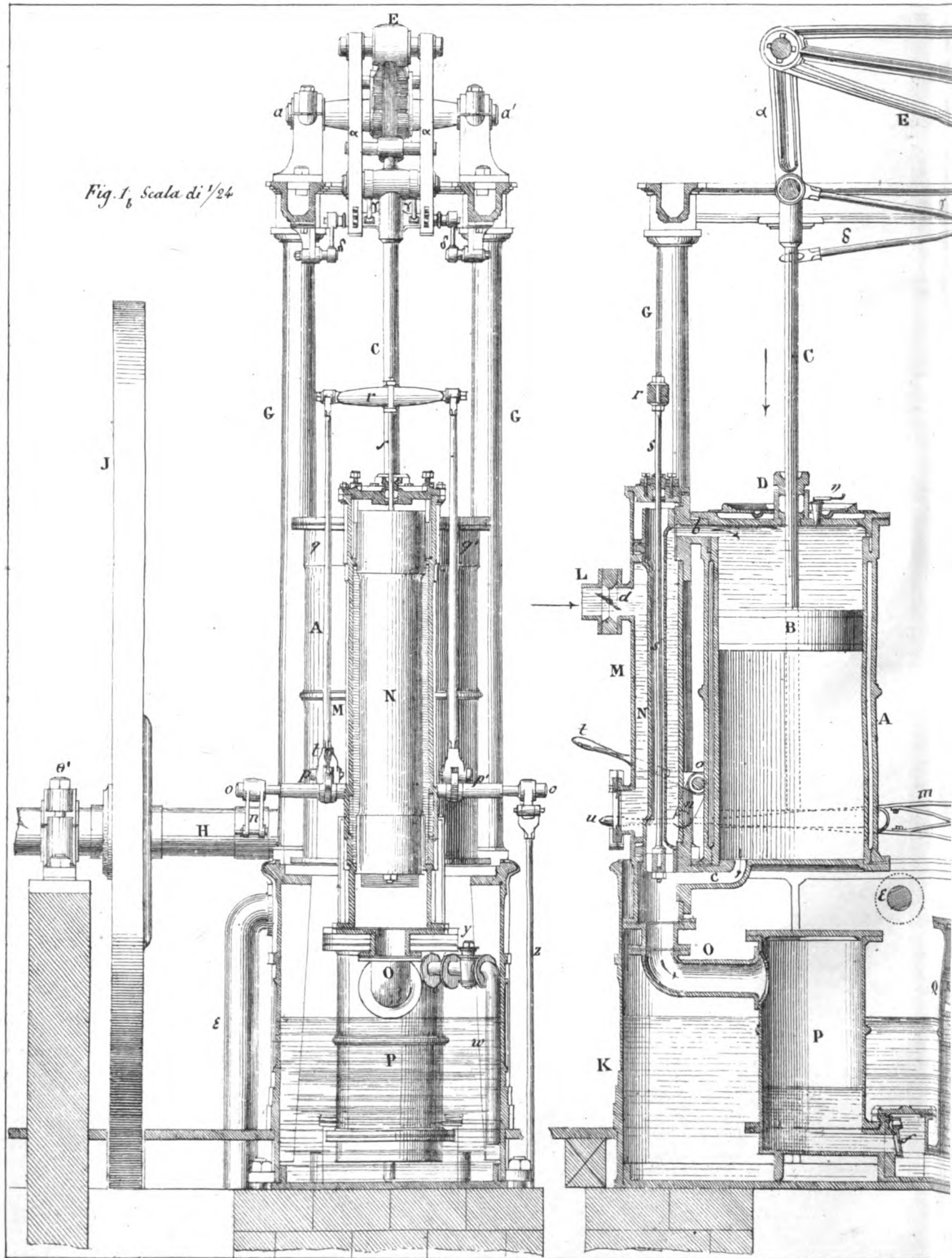
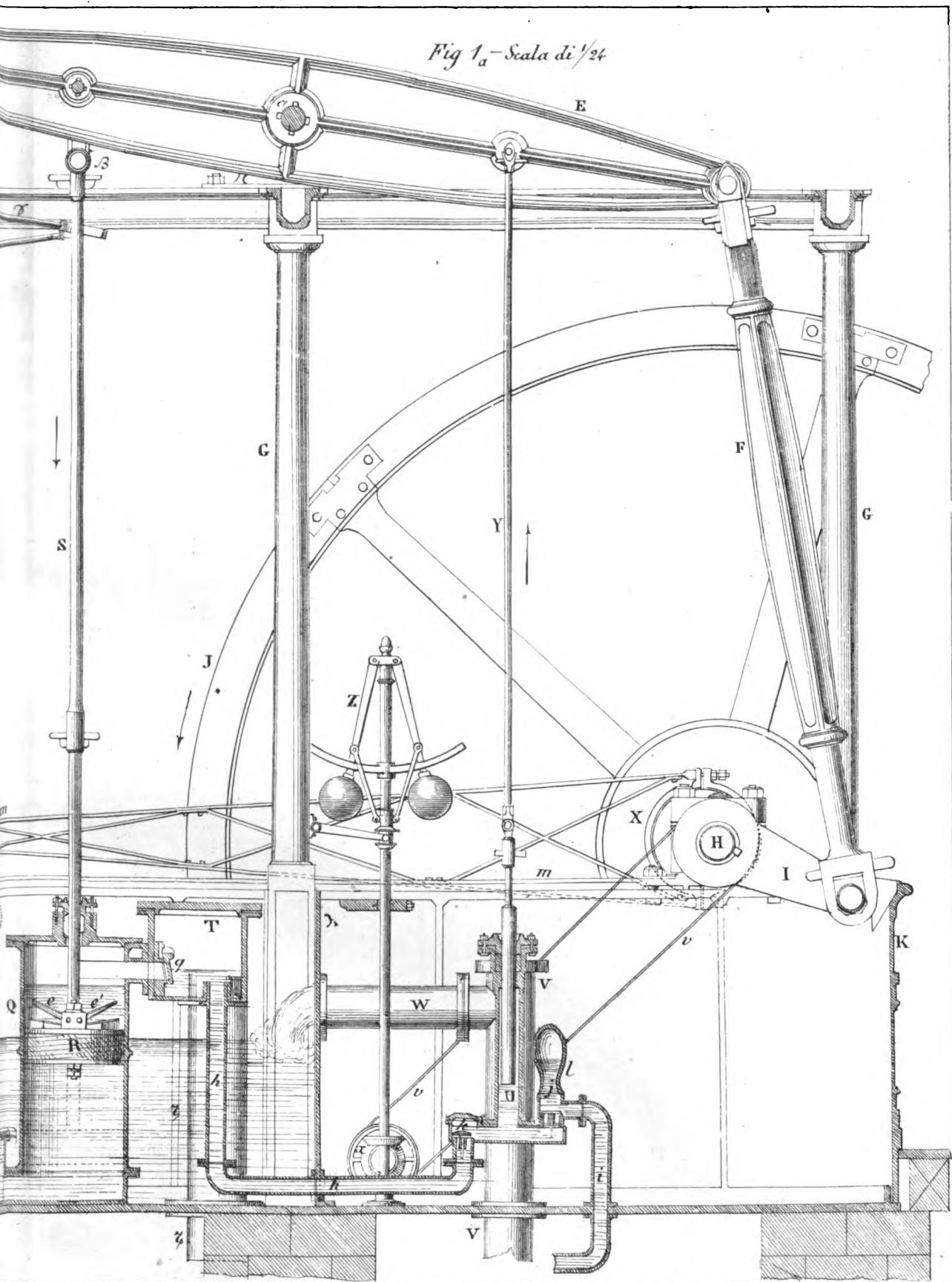

Fig. 1. Scala di 1/24

Cesare Randacio dis.

Torino Lit P. Briosio Via S. Francesco



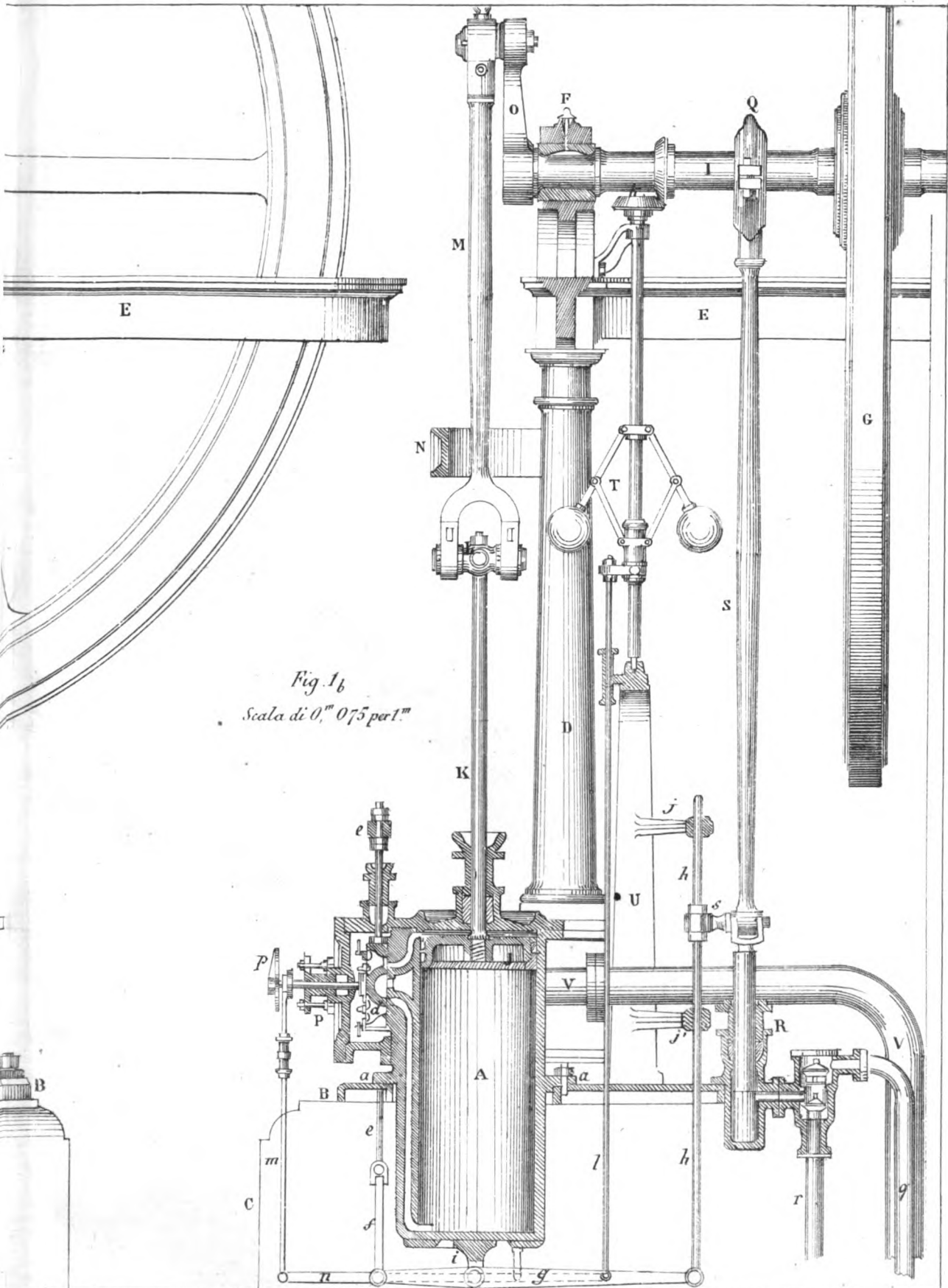

Fig. 1b
Scala di 0,075 per 1.

Fig 1_a - Scala di 1/20

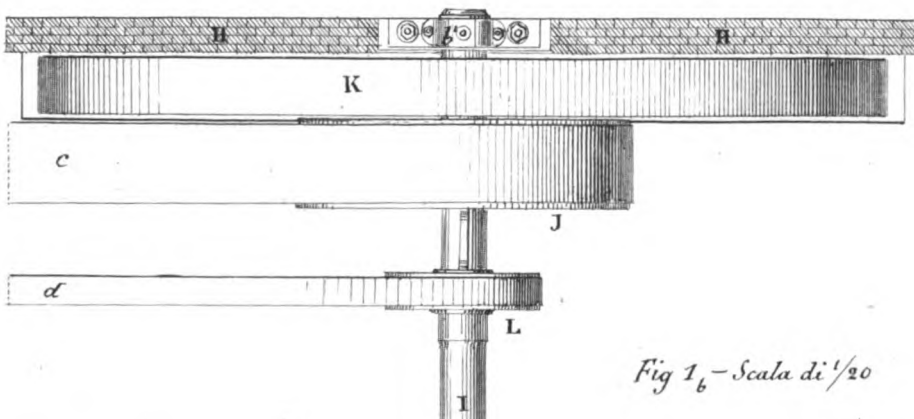
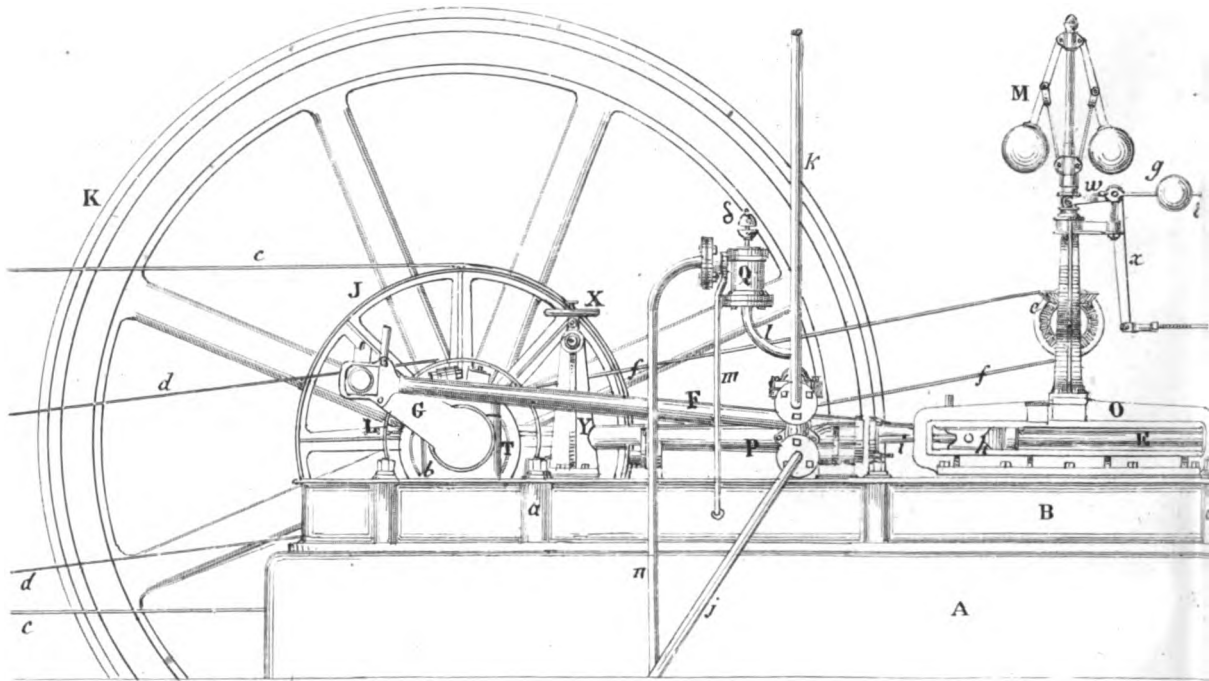

Fig 1_b
Scala di 0,075 per 1^m

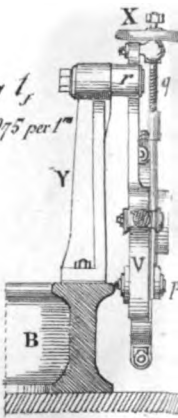

Fig 1_c - Scala di 1/20

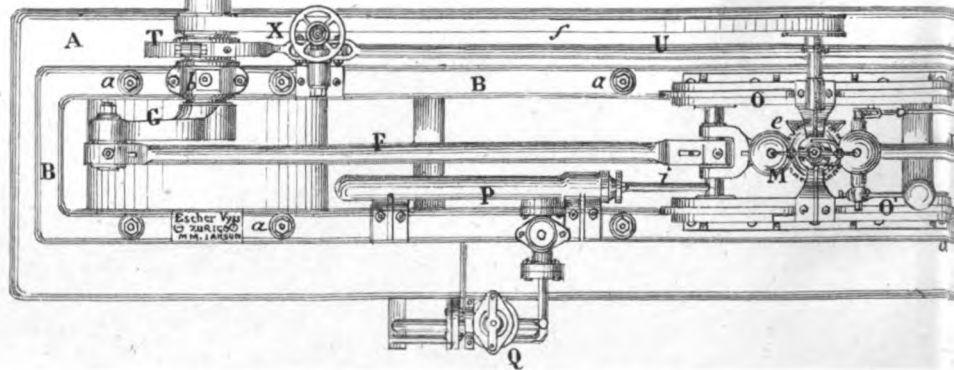

Fig. 1_c - Scala di 0.^m075 per 1.^m

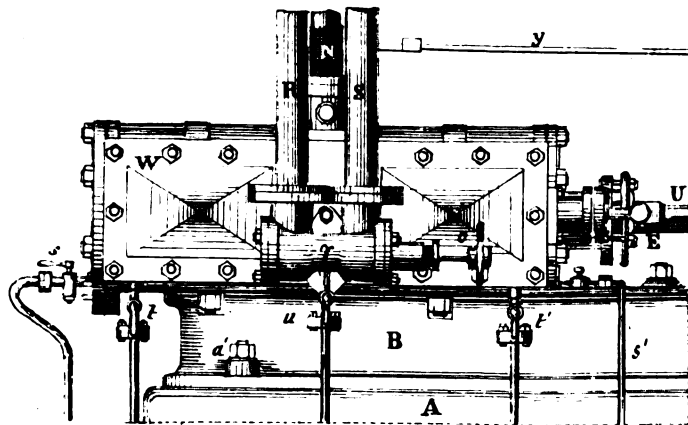

Fig. 1_d - Scala di 0.^m075 per 1.^m

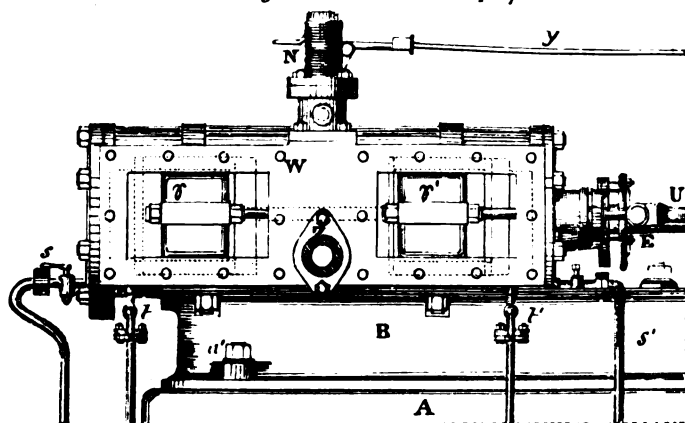

Fig. 1_g - Scala di 0.^m075 per 1.^m

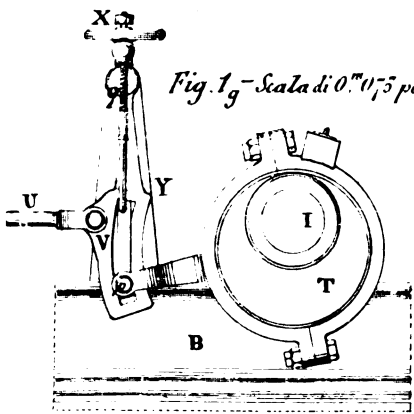

Fig. 1_e - Scala di 0.^m075 per 1.^m

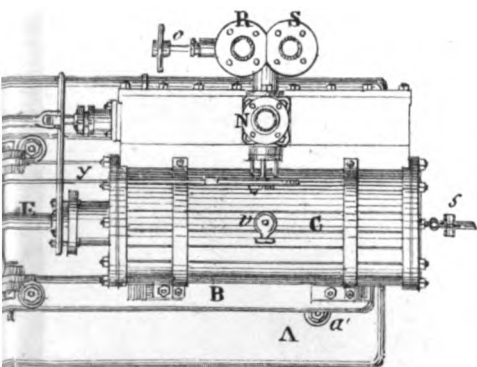
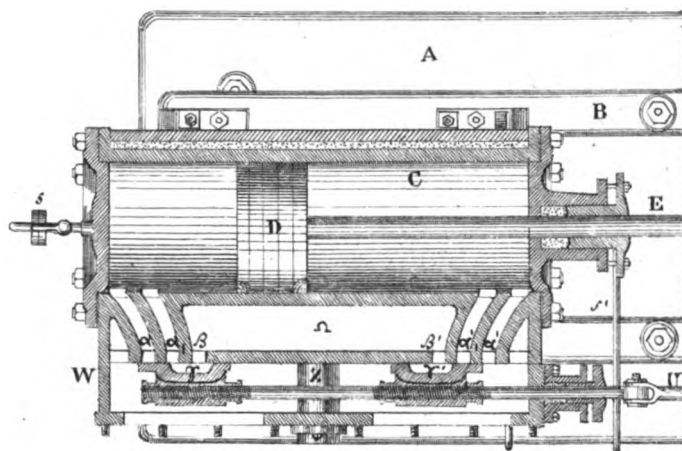
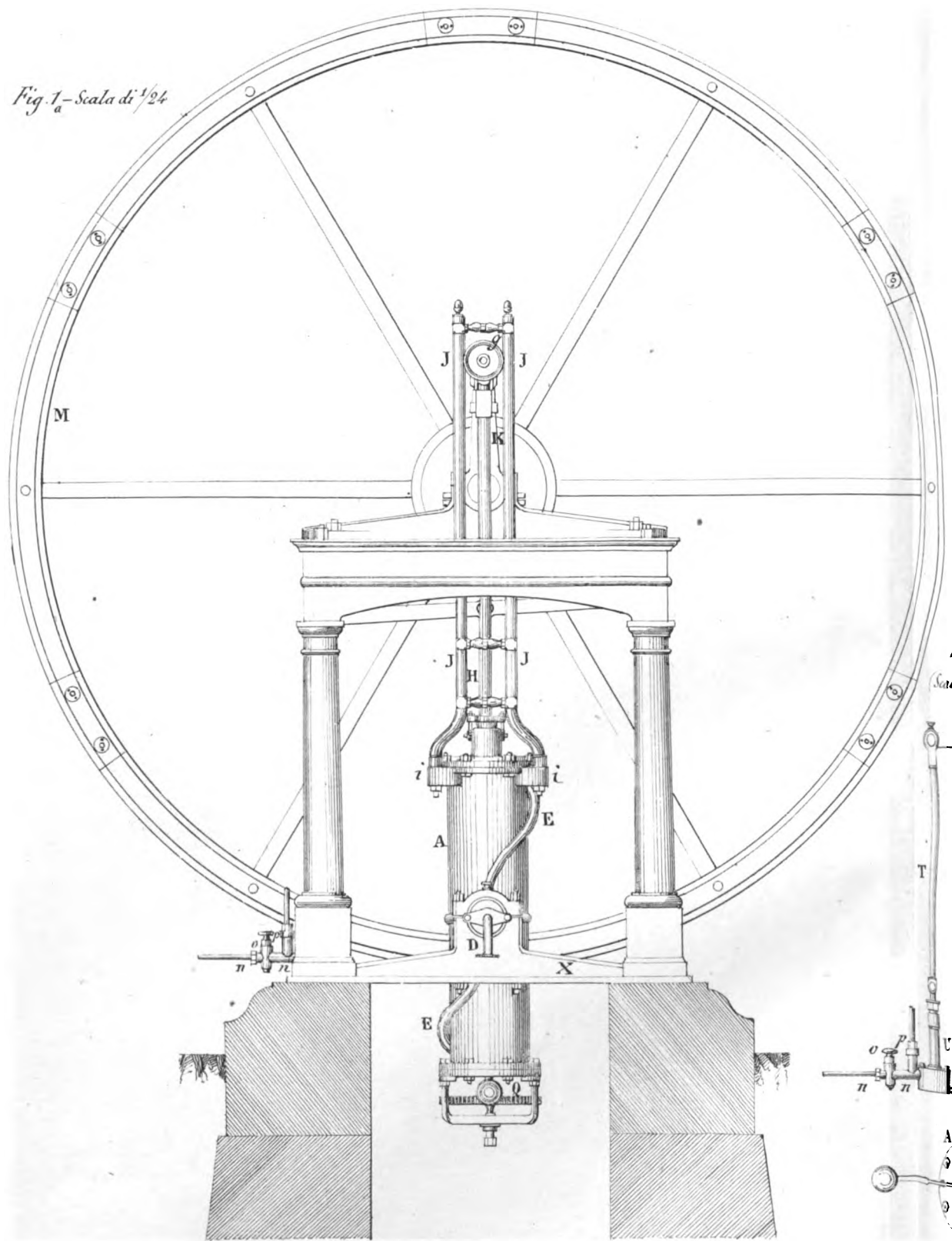

Fig. 1_a - Scala di 1/24



Luigi Mazè dis.

Lit. P. Briola Via S. Francesco

Fig. 1c - Scala di 1/24

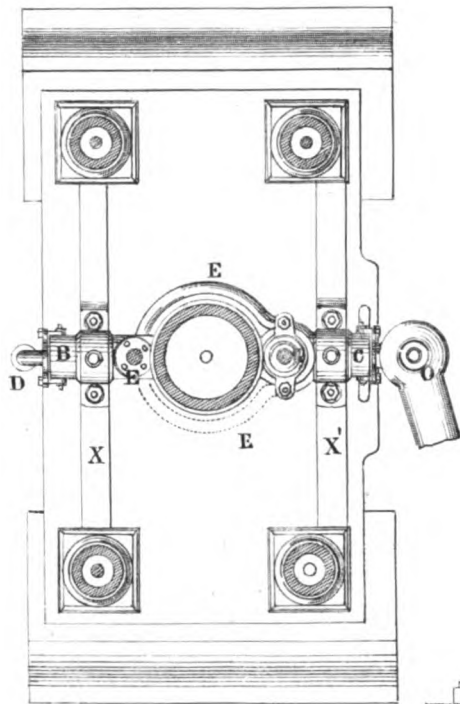

Fig. 1b
Scala di 1/24

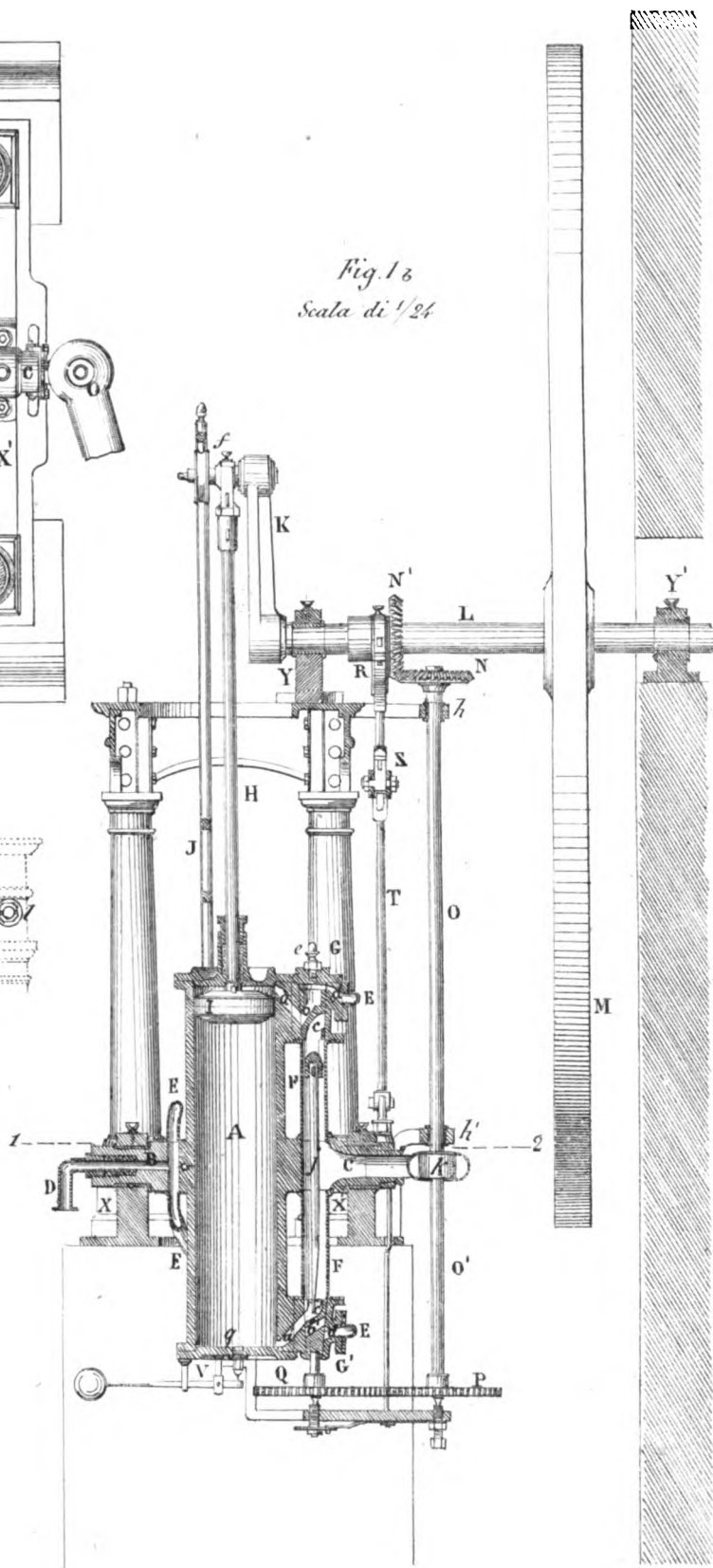

Fig. 1e
Scala di 1/24

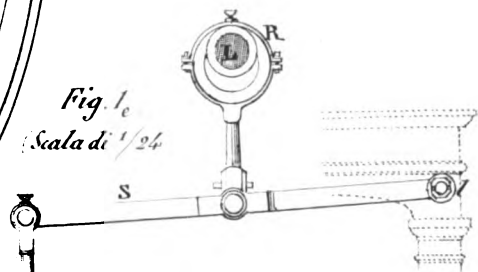

Fig. 1d - Scala di 1/24

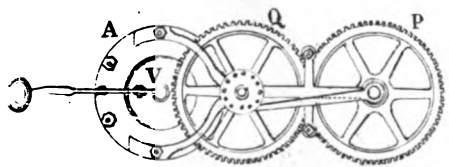

Fig. 4_a - Scala di 0,048 per 1

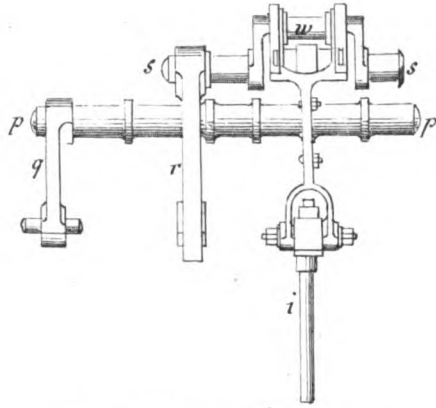

Fig. 4_b - Scala di 0,048 per 1

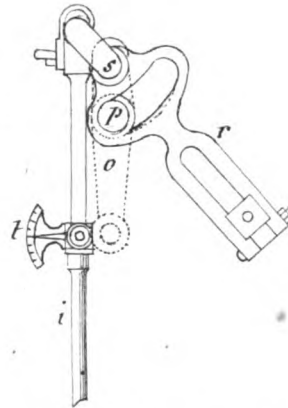

Fig. 5_a - Scala di 0,048 per 1^m

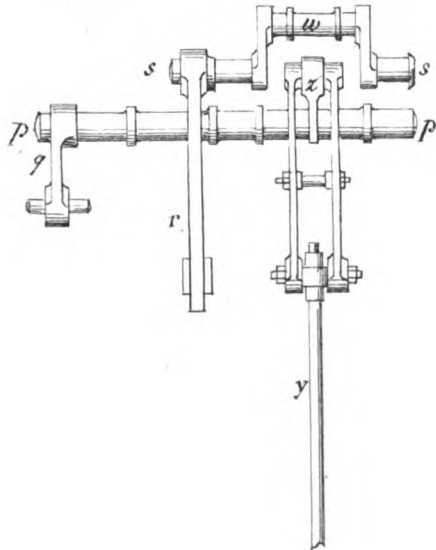

Fig. 5_b - Scala di 0,048 per 1^m

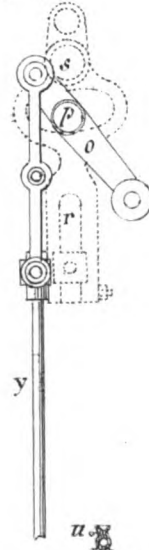

Fig. 1_a - Scala di 0,0384

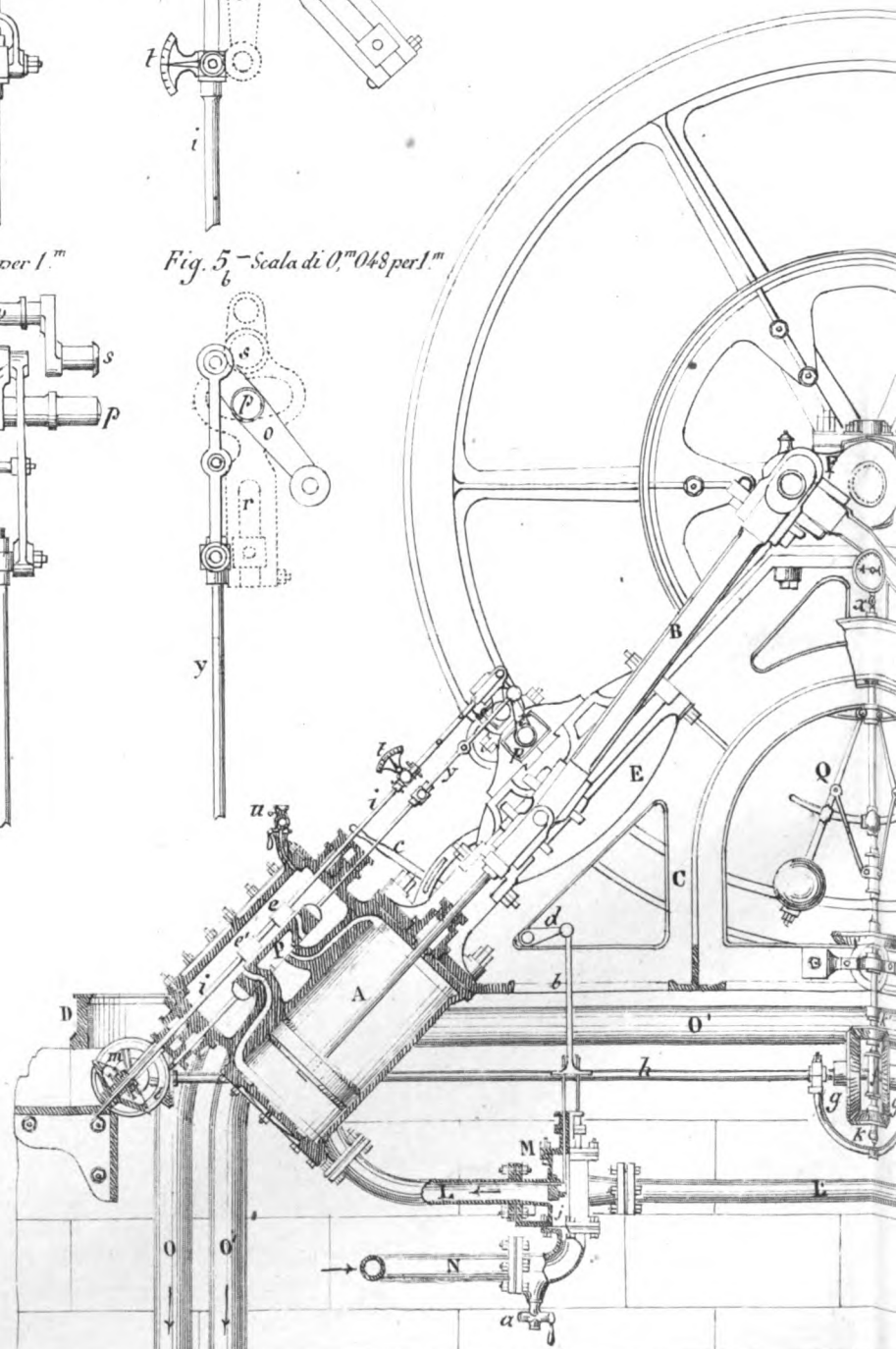

Fig. 2_b - Scala di 0,^m048 per 1

Fig. 2_a - Scala di 0,^m048 per 1.^m

384 per 1.^m

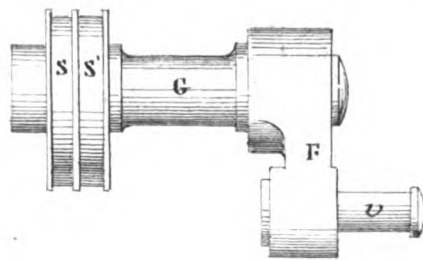
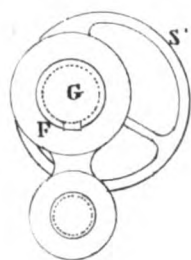

Fig. 3 - Scala di 0,^m048 per 1.^m

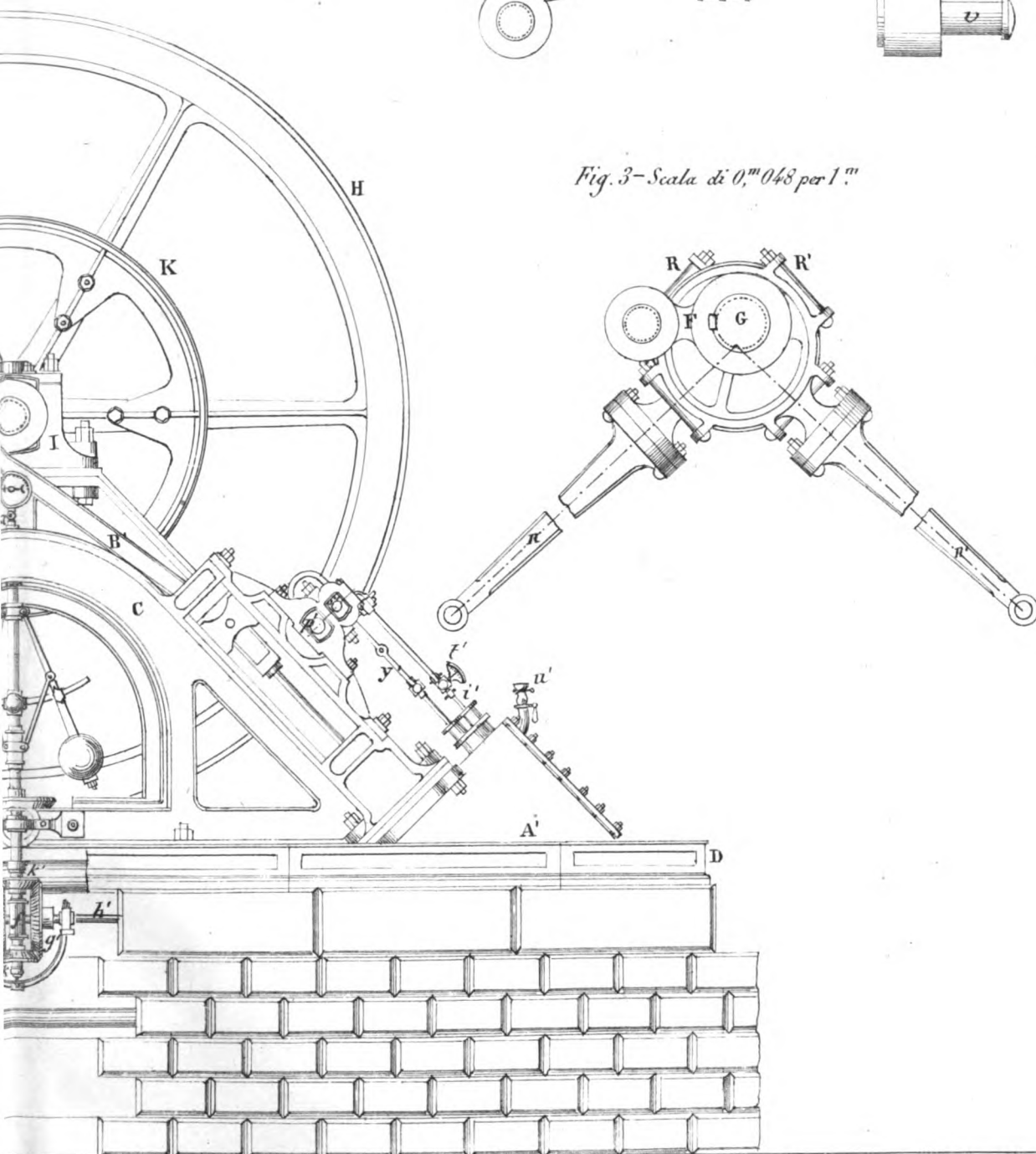
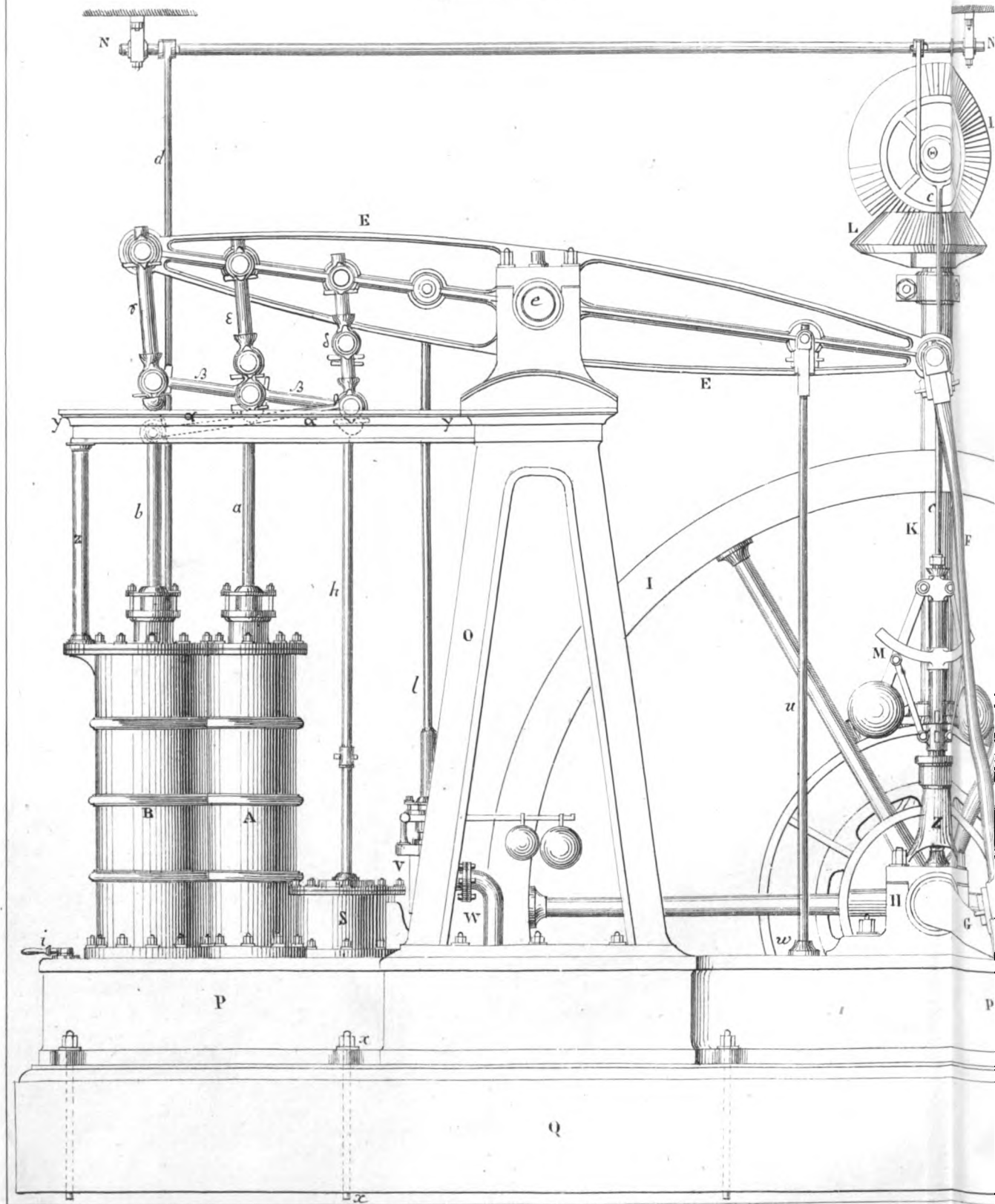

Fig. 1.-Scala di 1/20



Milano Giuseppe di

Torino Ad. P. B. & C. Via...

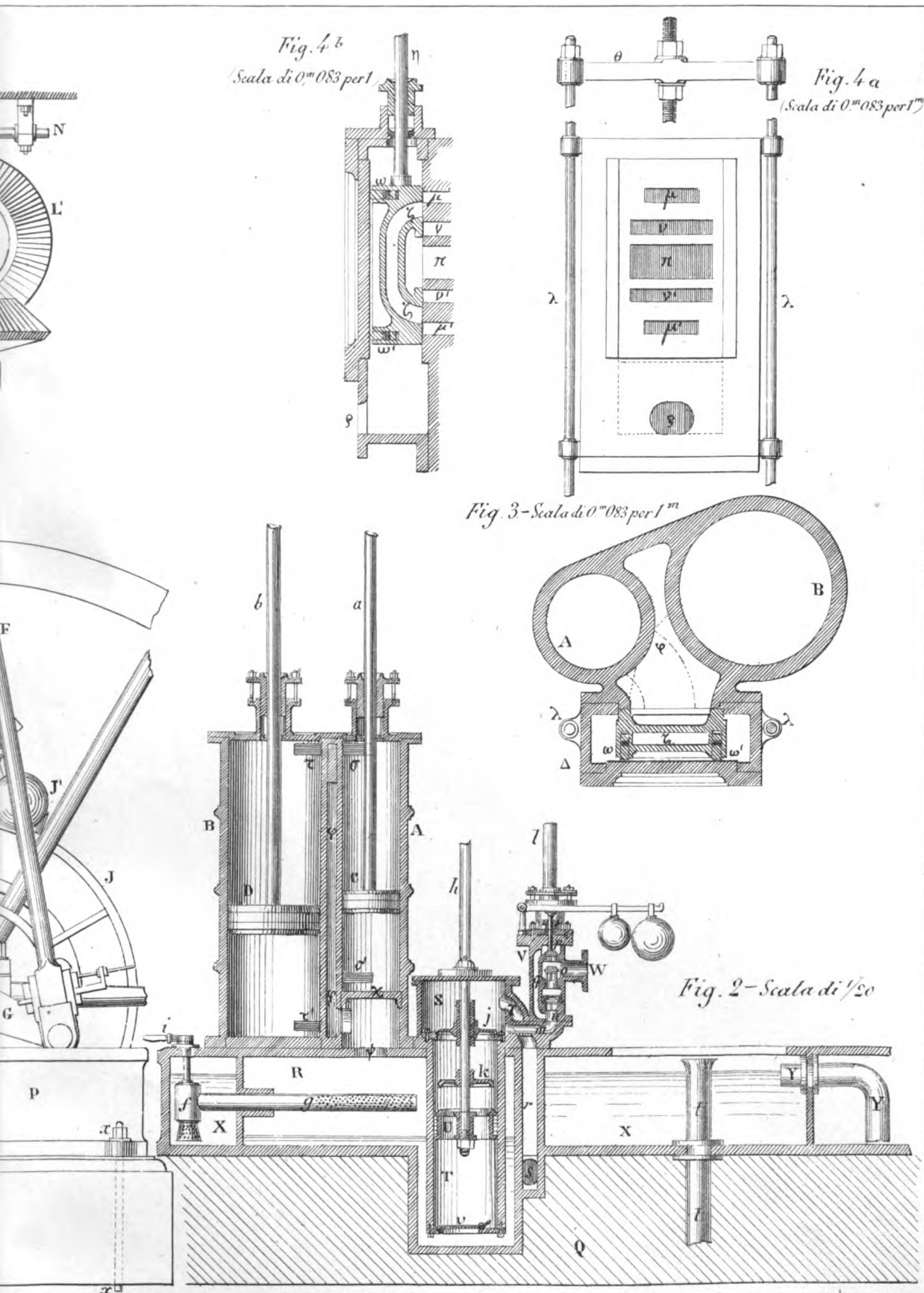

Fig. 1_a - Scala di 1/20

Fig. 1_b - Scala di 1/20

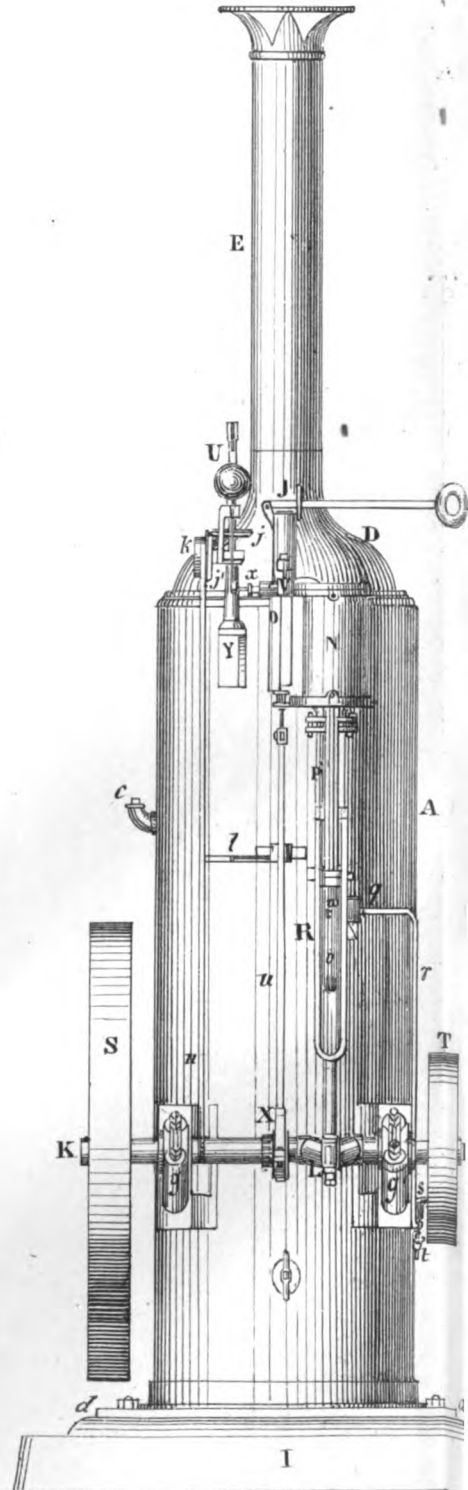
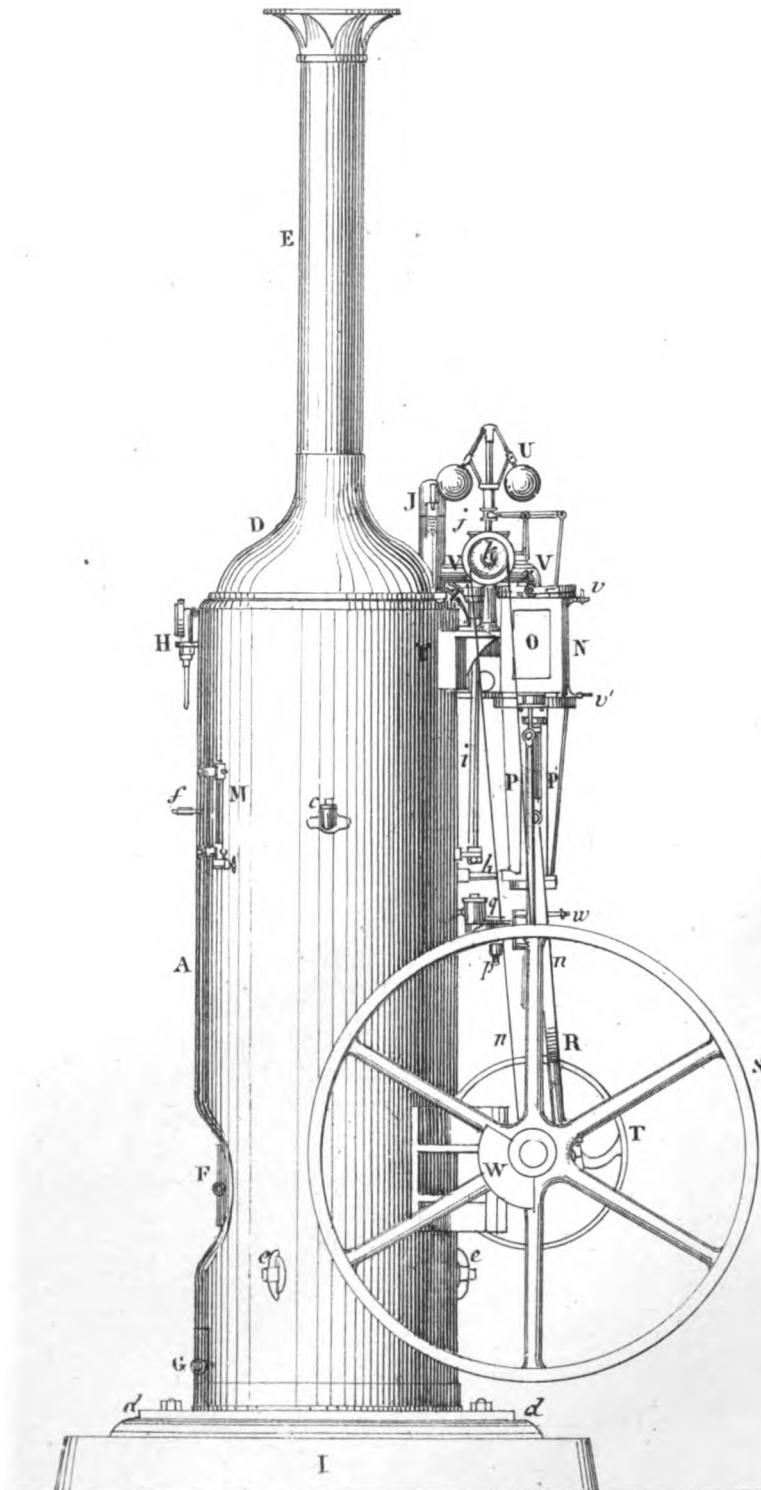

Fig. 1_c - Scala di 1/20

Fig. 1_d - Scala di 1/5

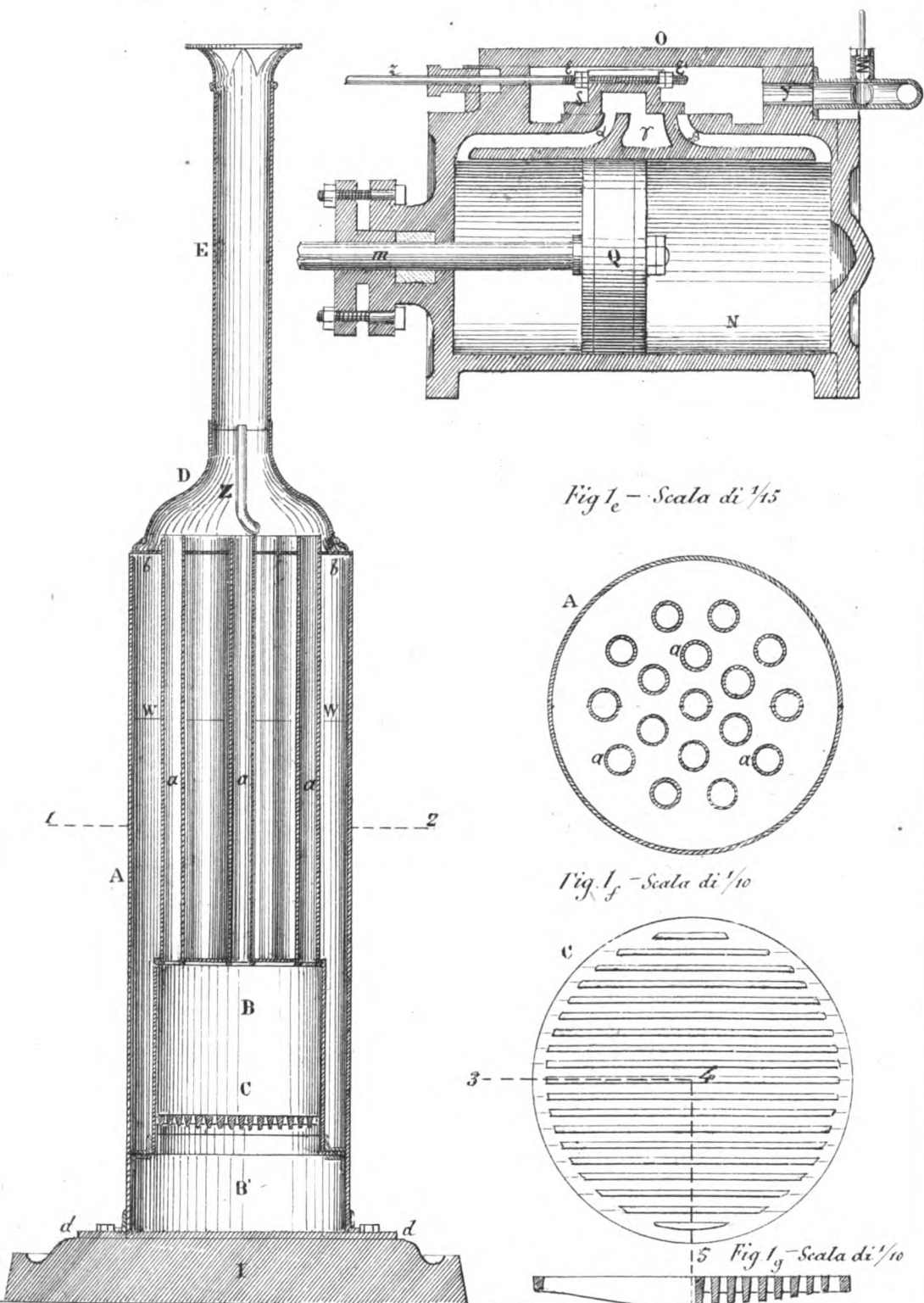

Fig. 1_e - Scala di 1/5

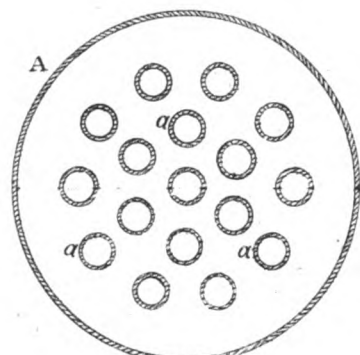

Fig. 1_f - Scala di 1/10

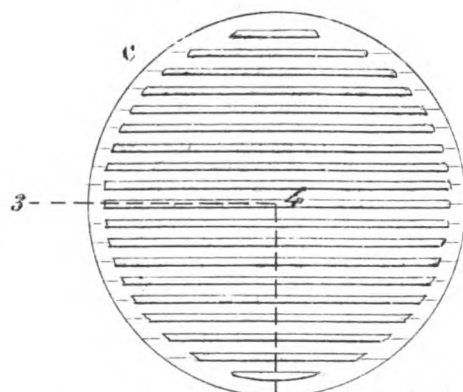
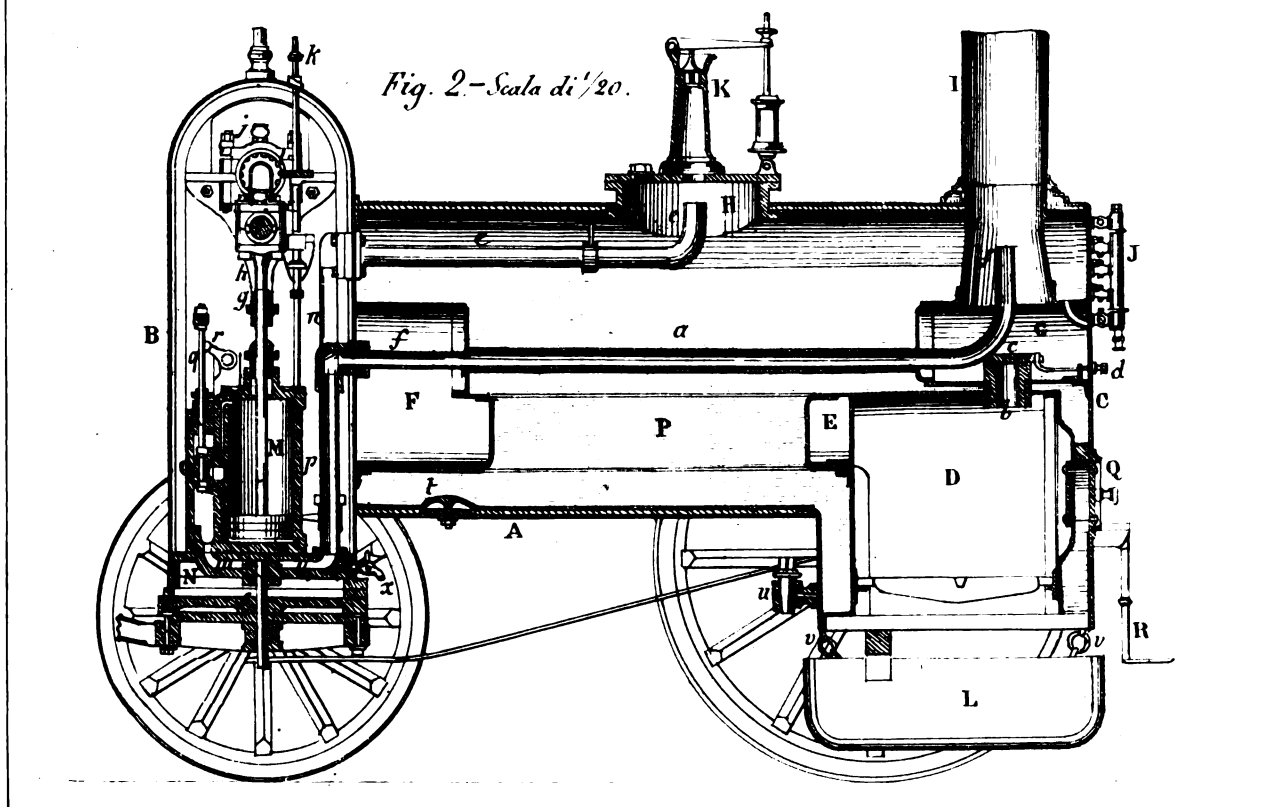
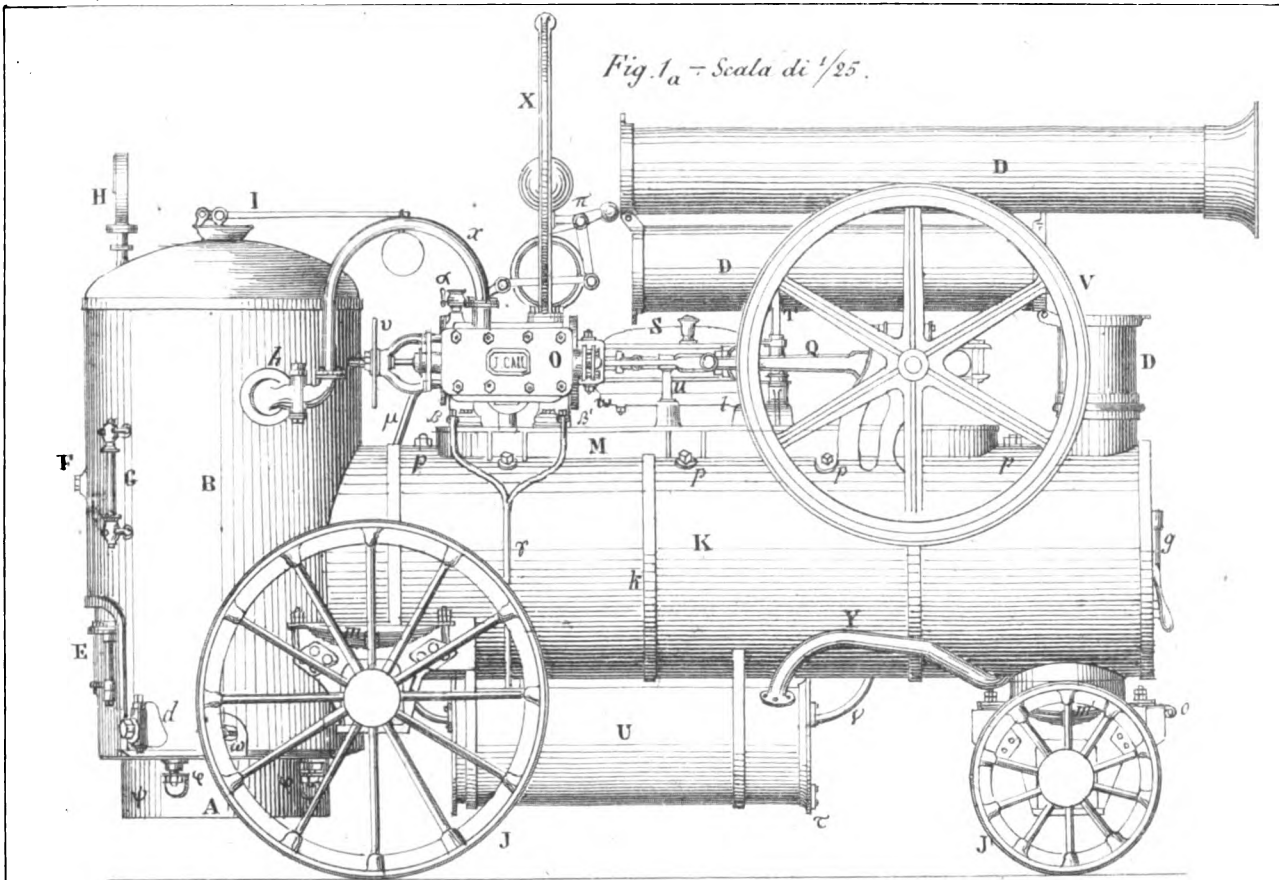

Fig. 1_g - Scala di 1/10





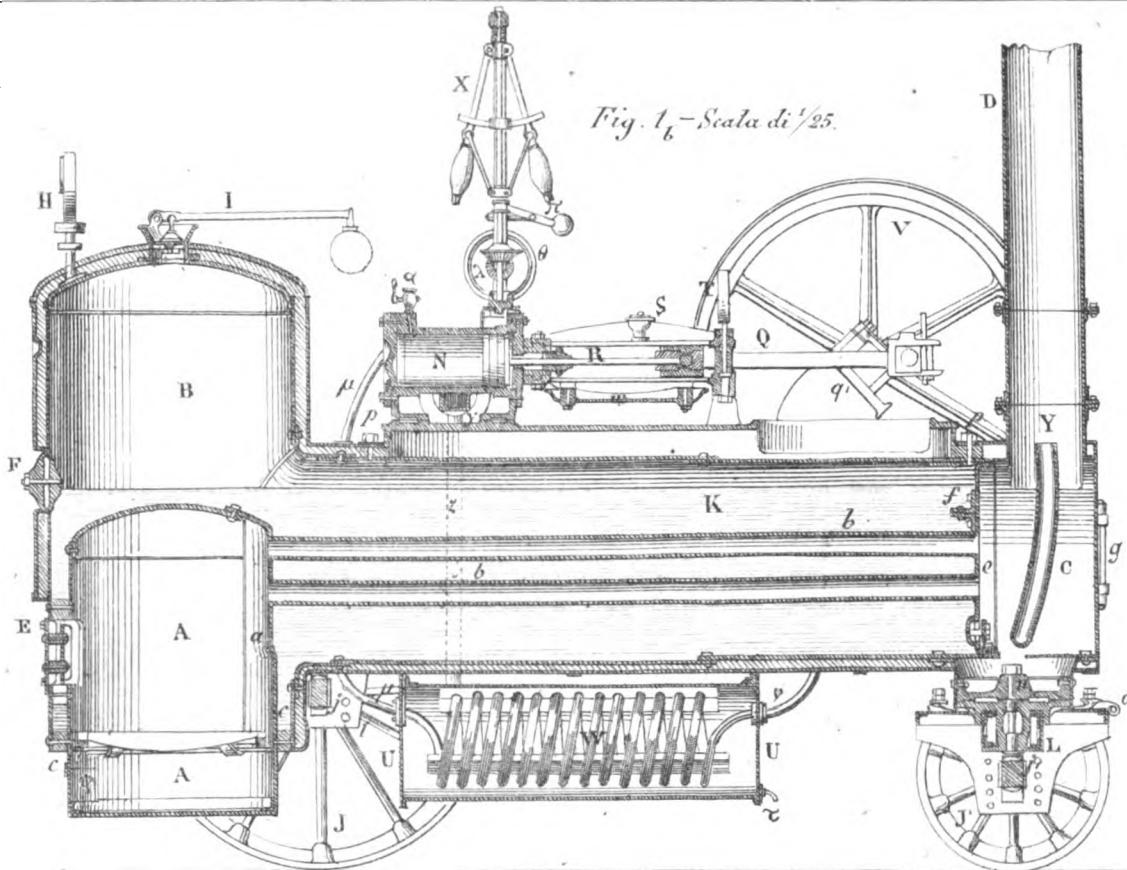

Fig. 1c - Scala di 1/25

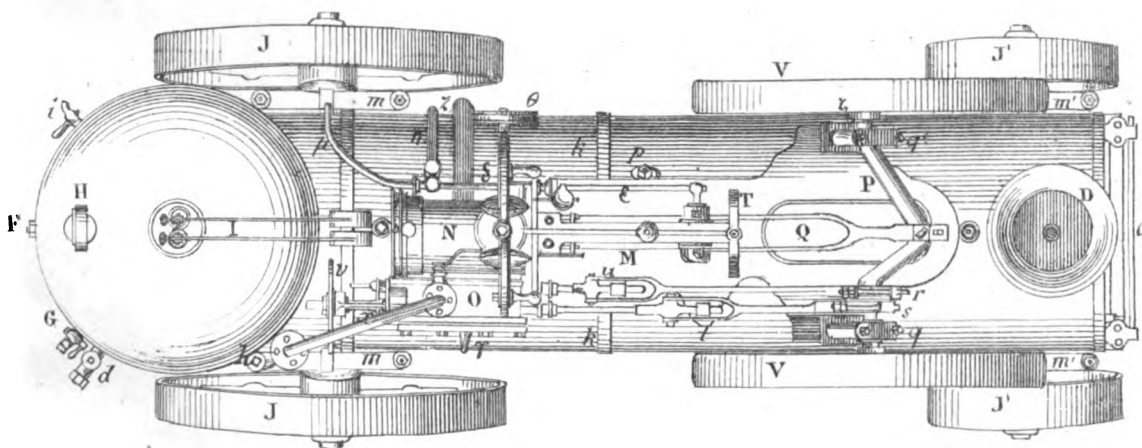

Fig. 1.
(Scala di 1/40)

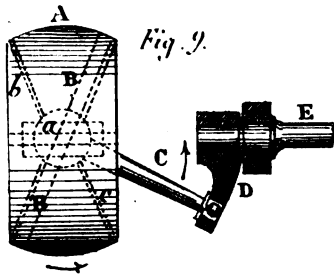
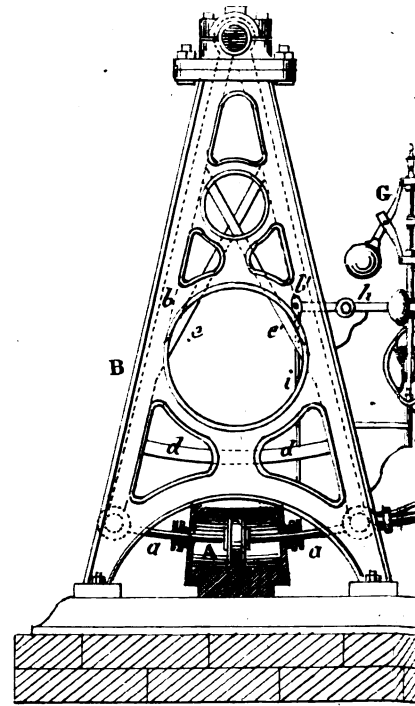
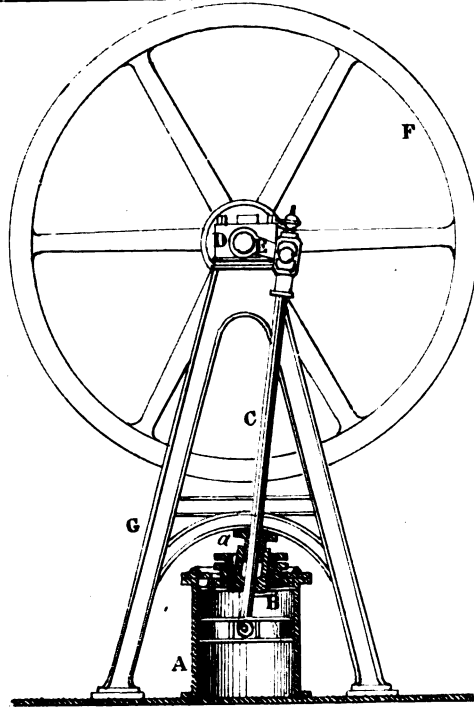

Fig. 9.

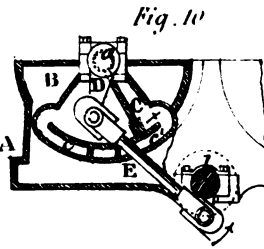

Fig. 10

Fig. 5 - Scala

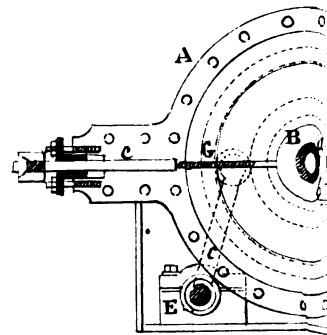

Fig. 4 - Scala di 20

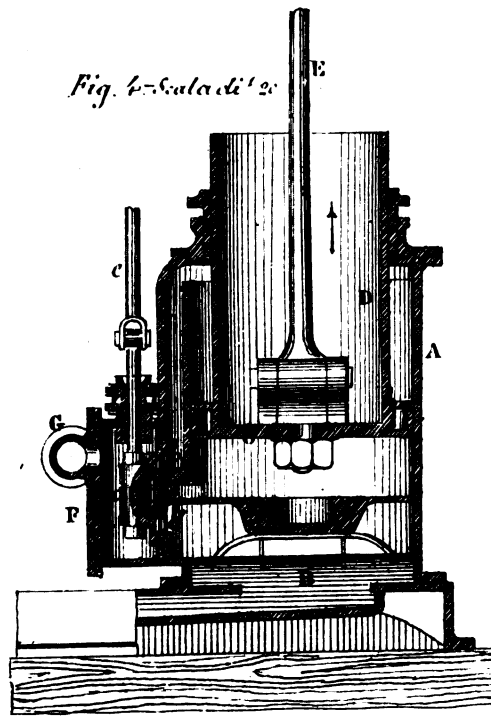

Fig. 8.

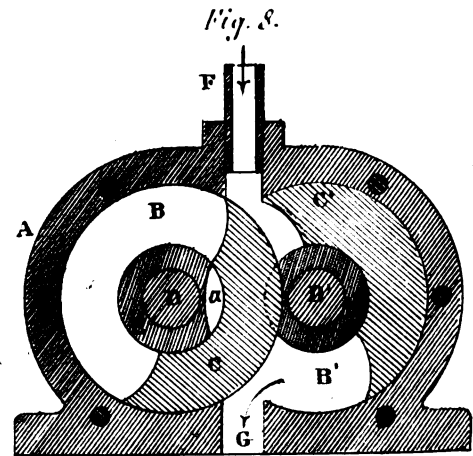

Fig. 2 - Scala di 1/15.

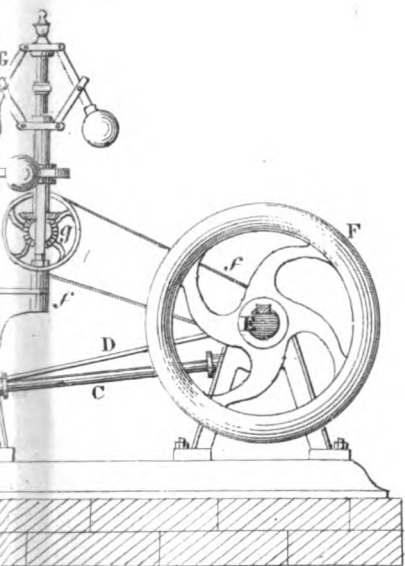
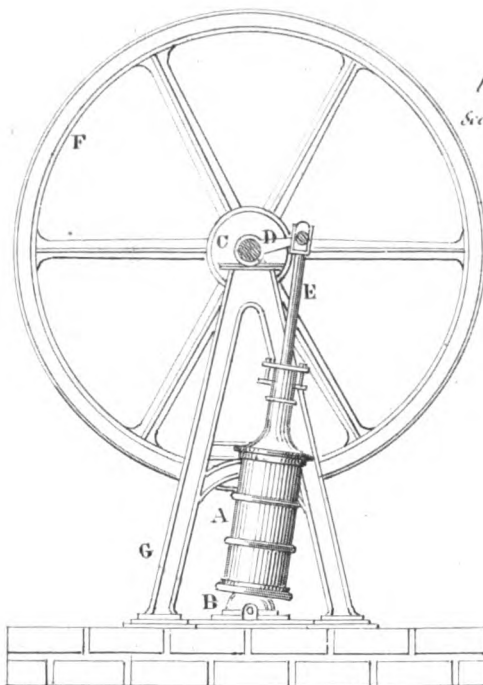

Fig. 3_a
Scala di 1/50



Scala di 1/15

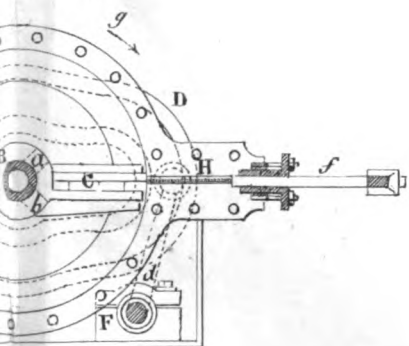

Fig. 3_b - Scala di 1/20.

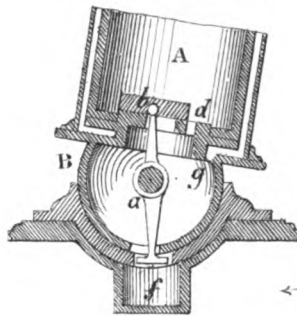

Fig. 3_c - Scala di 1/20.

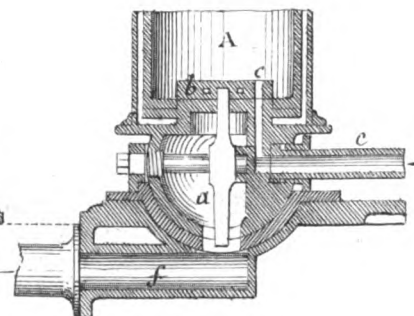

Fig. 7 - Scala di 1/15.

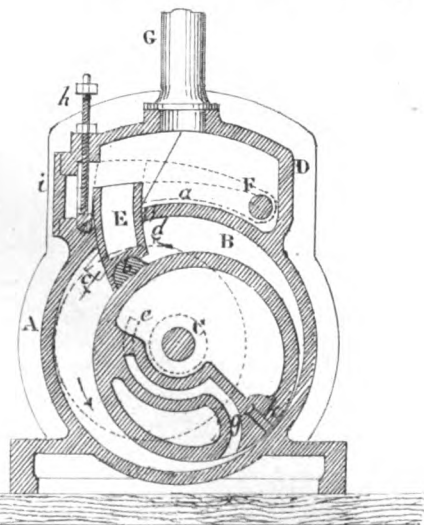
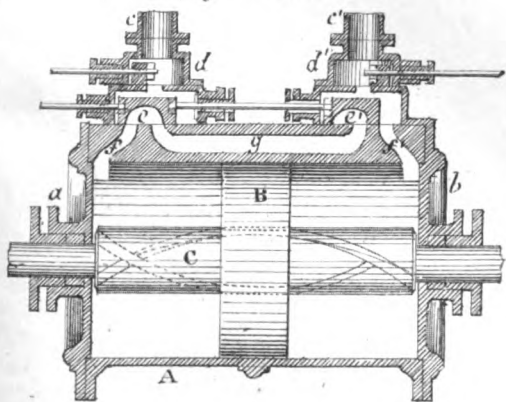
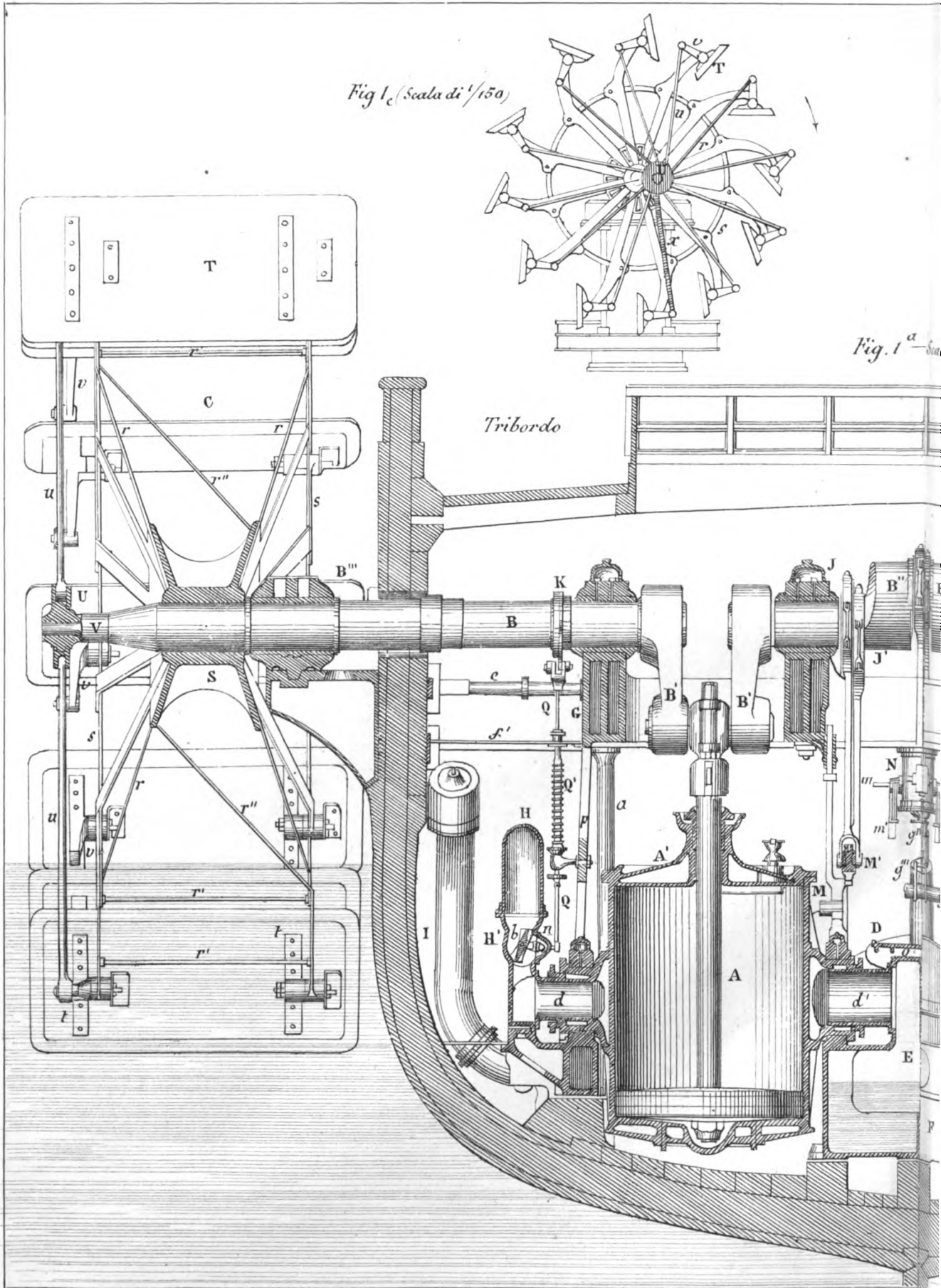

Fig. 6 - Scala di 1/20.





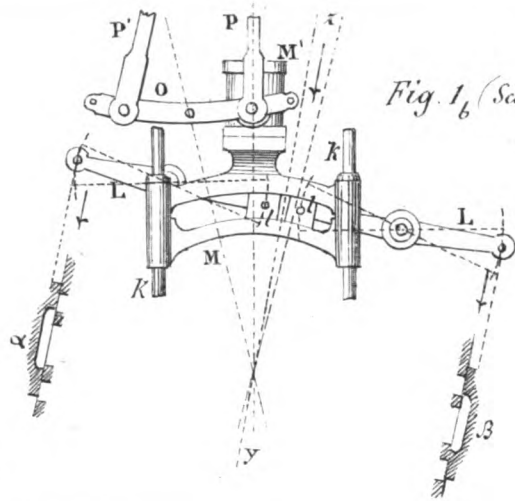
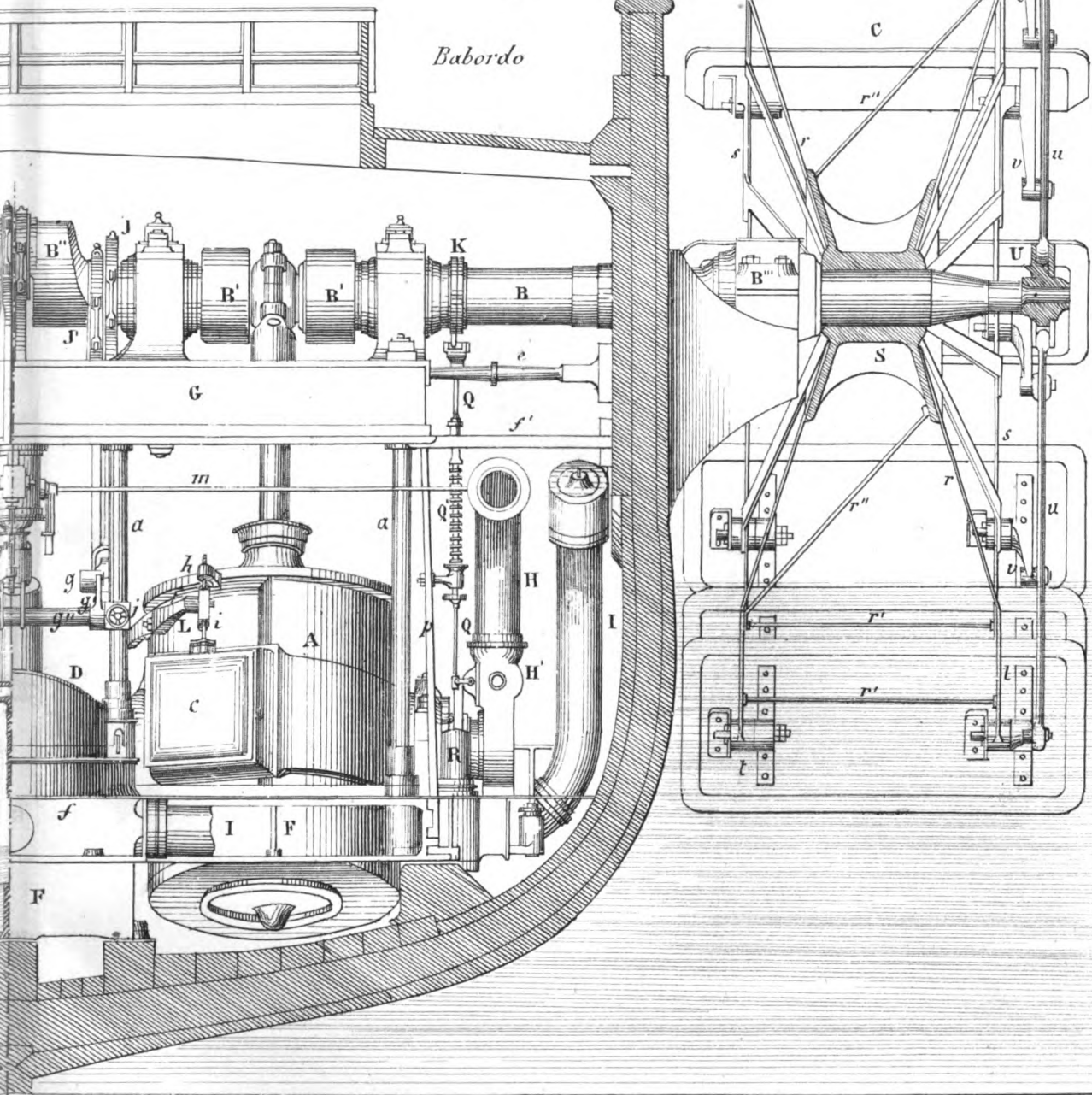
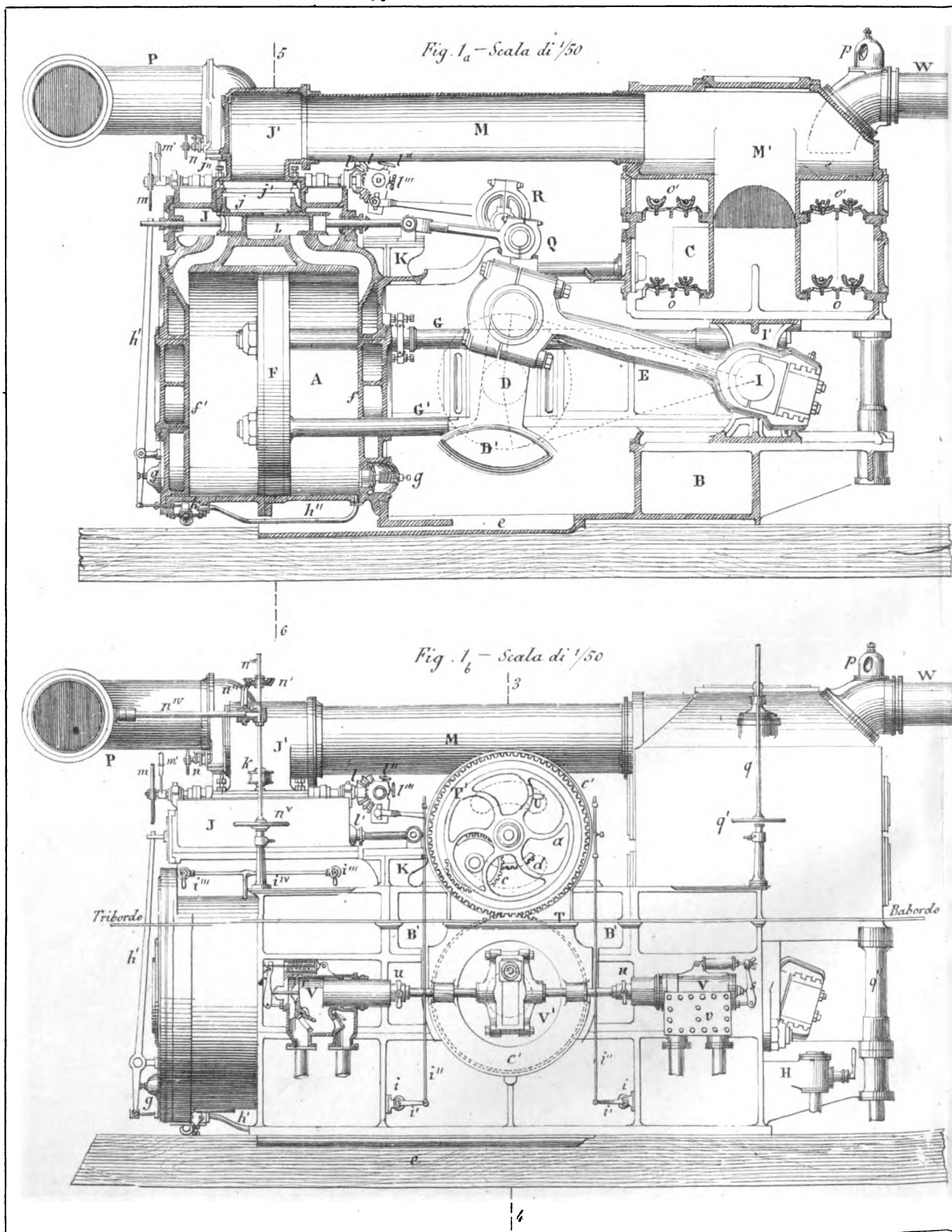

Fig. 1, (Scala di 0^m 0²⁷ per 1^m)

Scala di 1/50



Babordo



Randone Tribaldo dis

Torino Lit. P. Briosi Via S. Anna

Fig. 5_b - Scala di 0,015 per 1^m

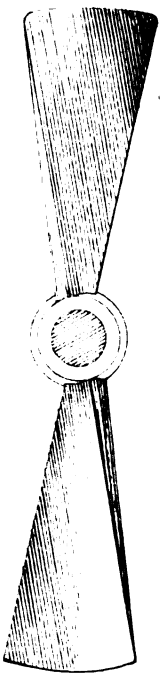

Fig. 2_a - Scala di 1/50

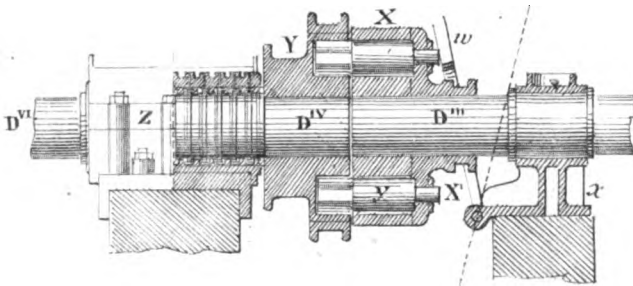

Fig. 3 - Scala di 1/10

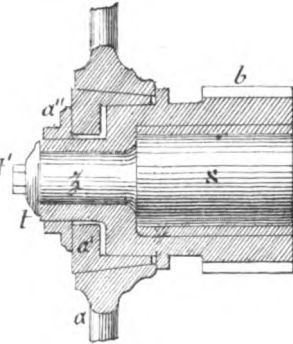

Fig. 2_b - Scala di 1/50

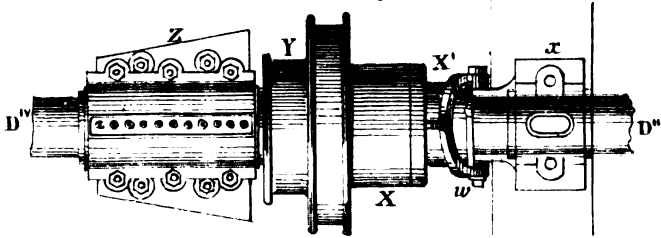

Fig. 4 - Scala di 1/10

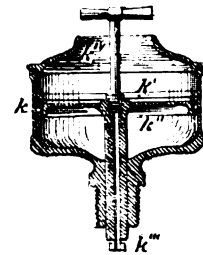

Fig. 1_c - Scala di 1/50

Fig. 5_a - Scala di 0,015 per 1^m

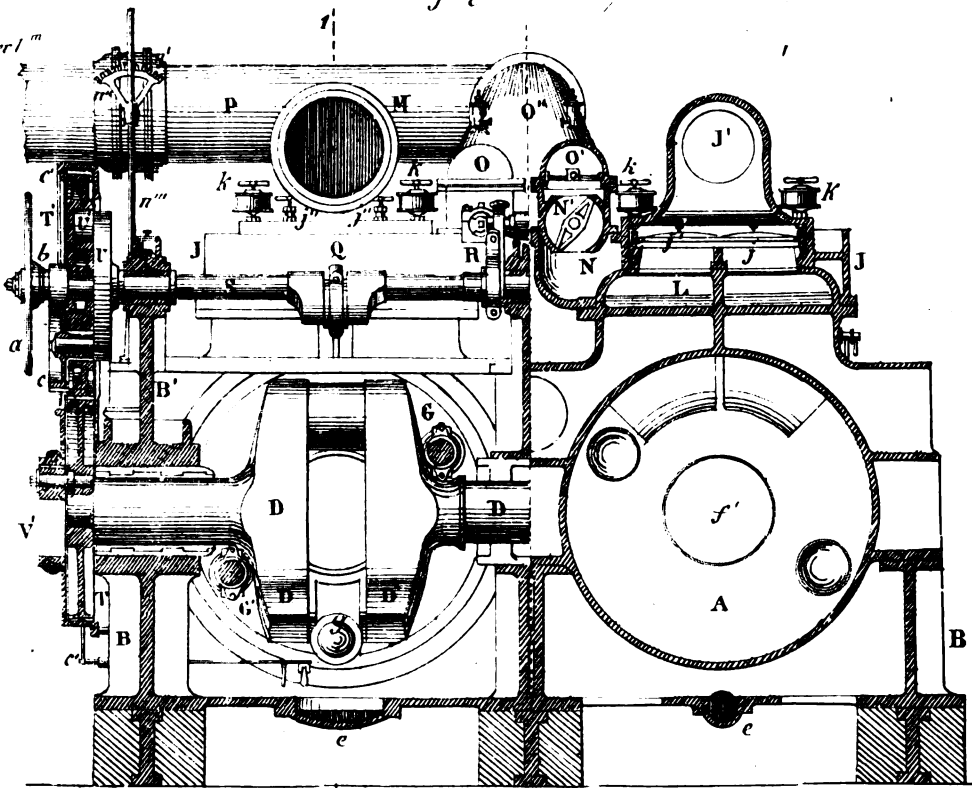
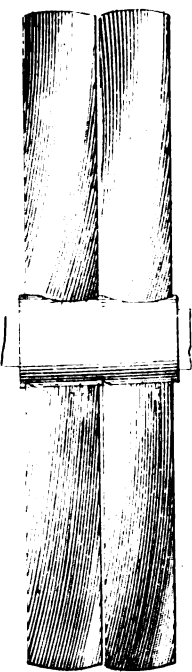
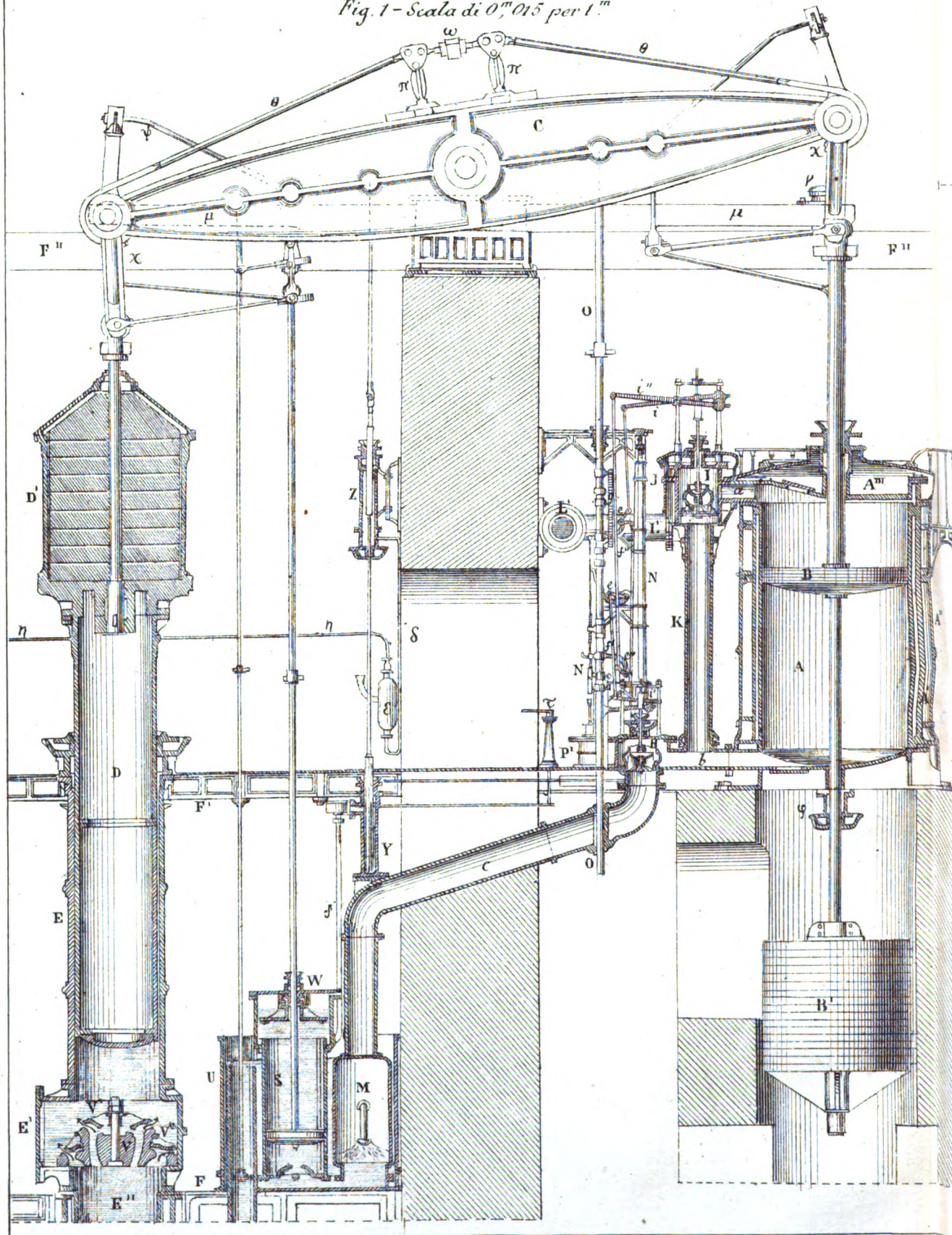

Fig. 1 - Scala di 0^m,015 per 1^m



G. V. Carona dis.

Lit. P. Brioia Via S. Fra.

Fig. 3^a - Scala di 1/25

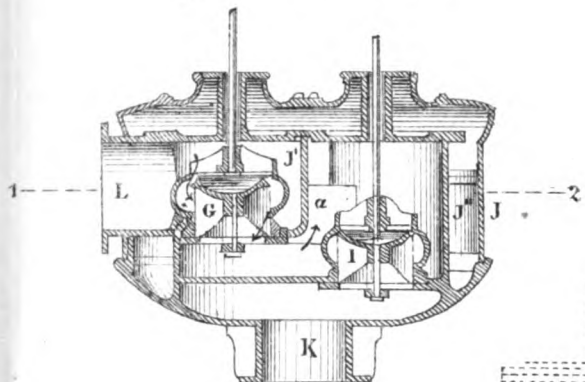

Fig. 2^a - Scala di 1/25

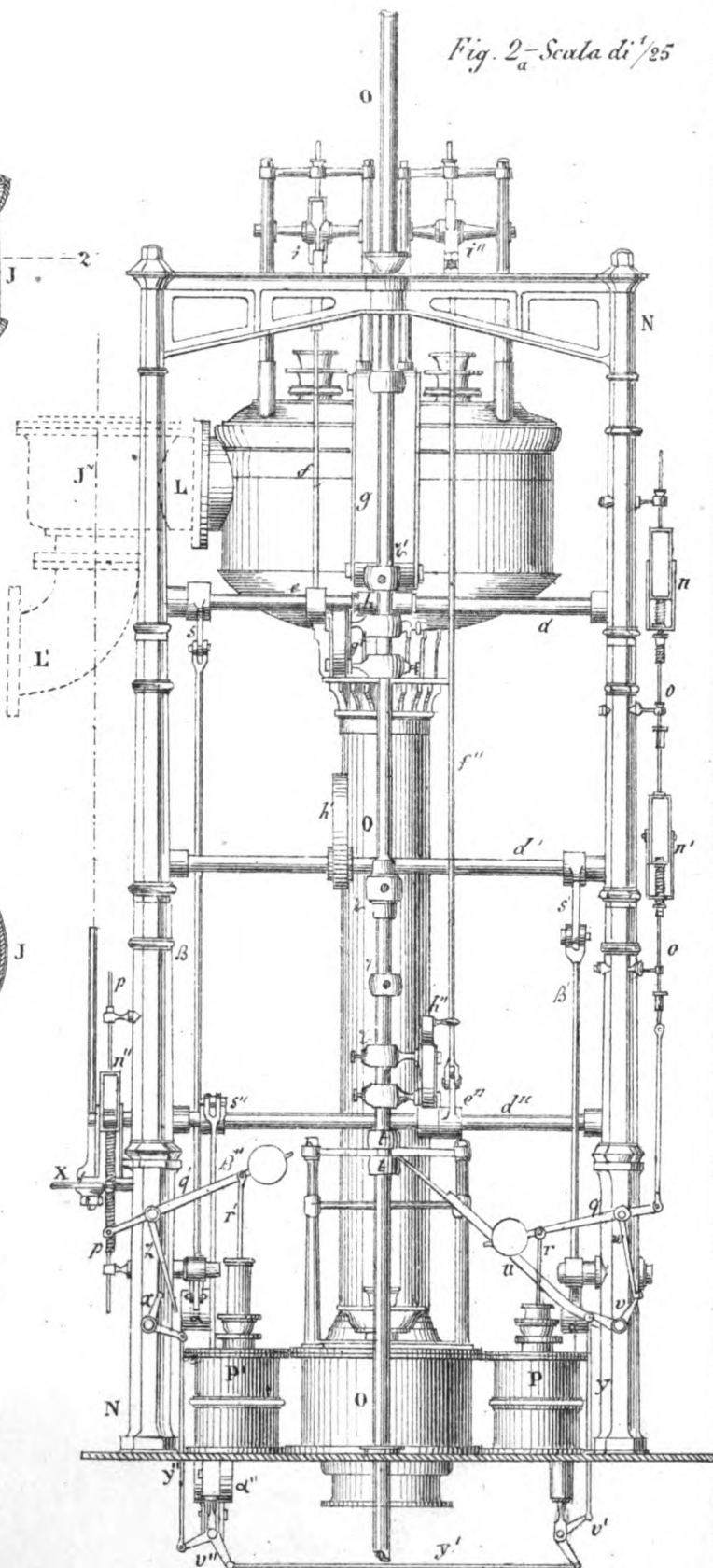

Fig. 2^b - Scala di 1/25

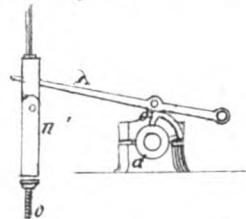

Fig. 3^b - Scala di 1/25

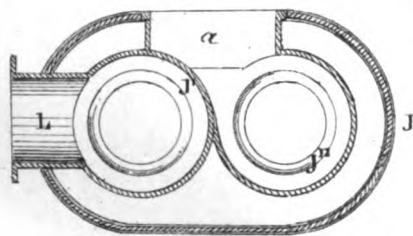

Fig. 4 - Scala di 1/10

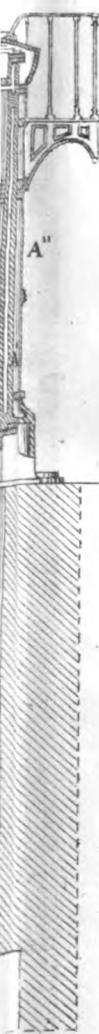
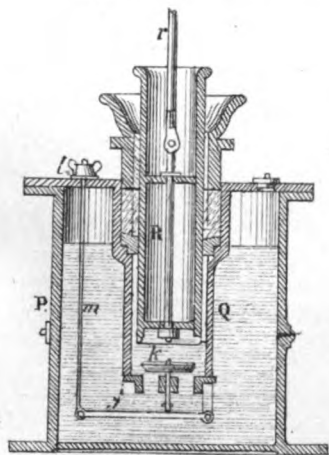

Fig 1_a - Scala di 1/12.

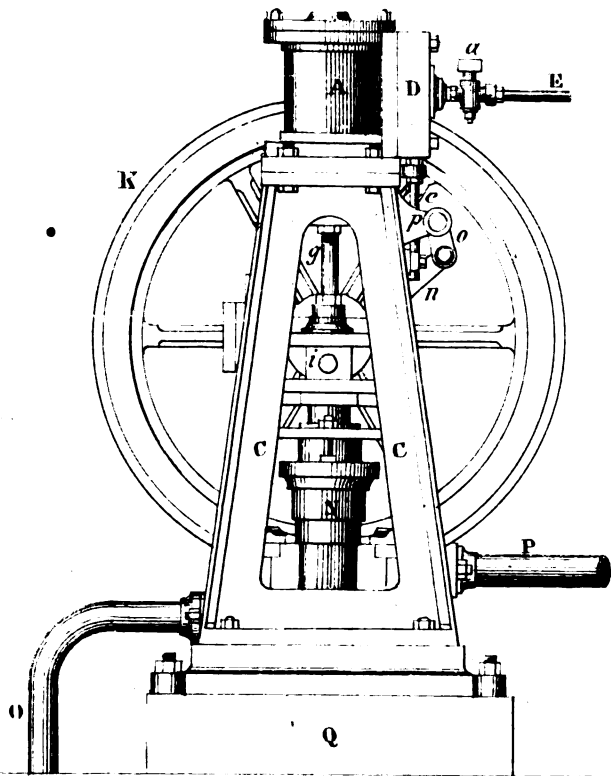

Fig 1_b - Scala di 1/12.

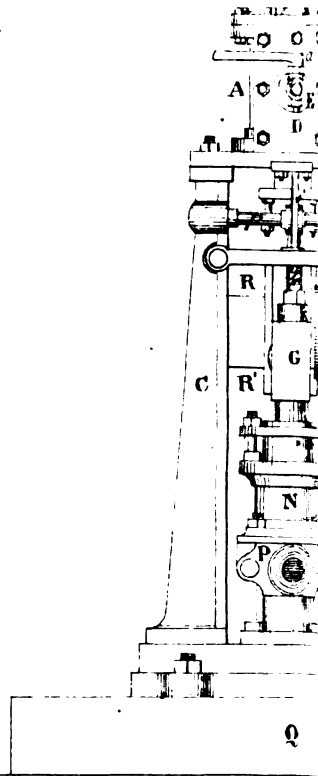

Fig. 2_a - Scala di 1/25.

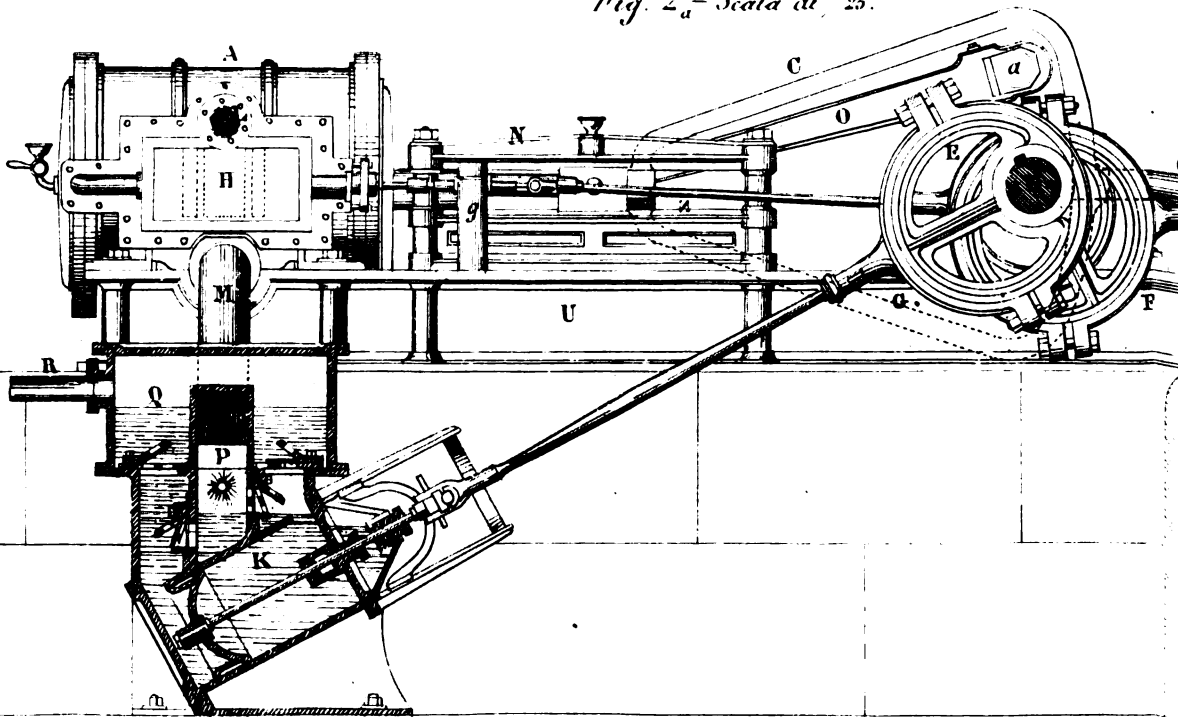

Fig. 1_a - Scala di 1/12.

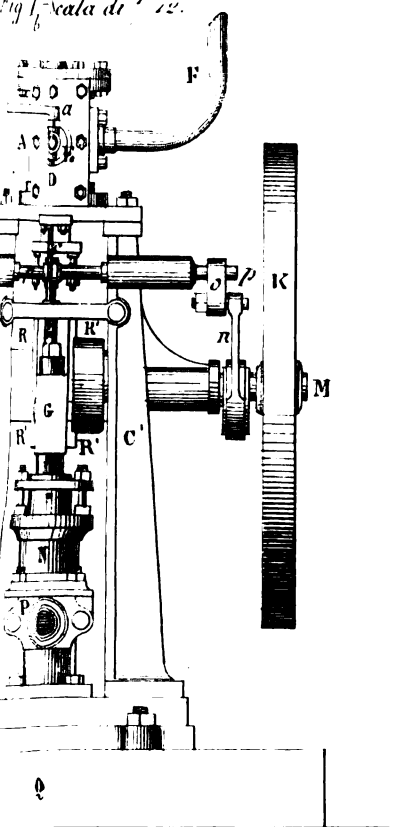

Fig. 1_c - Scala di 1/12.

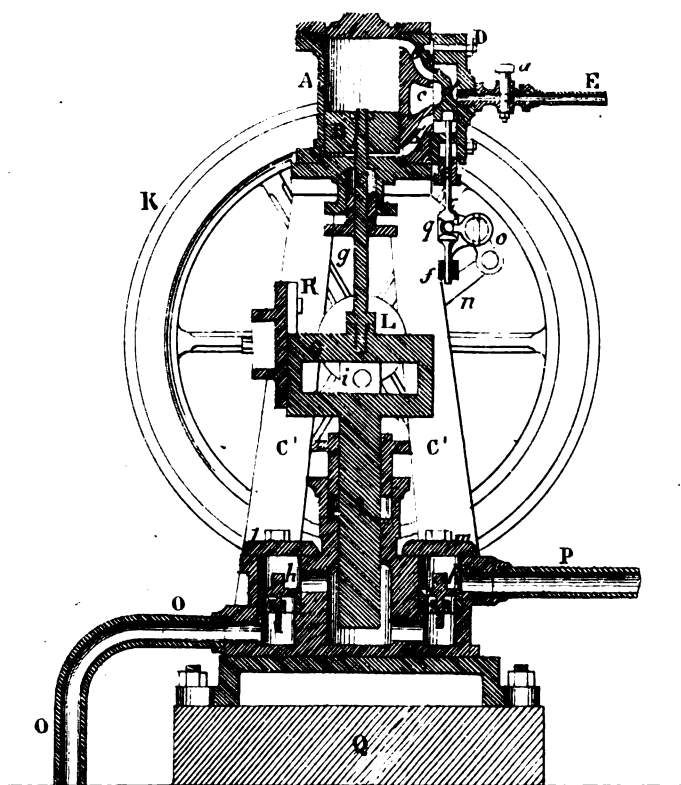
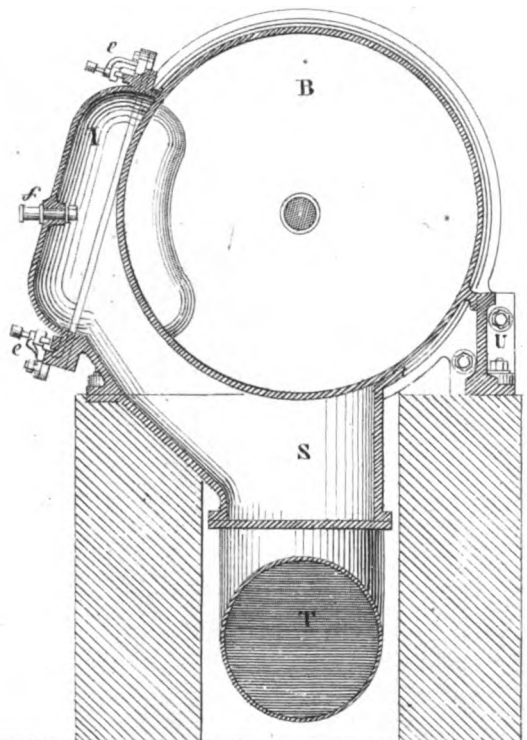
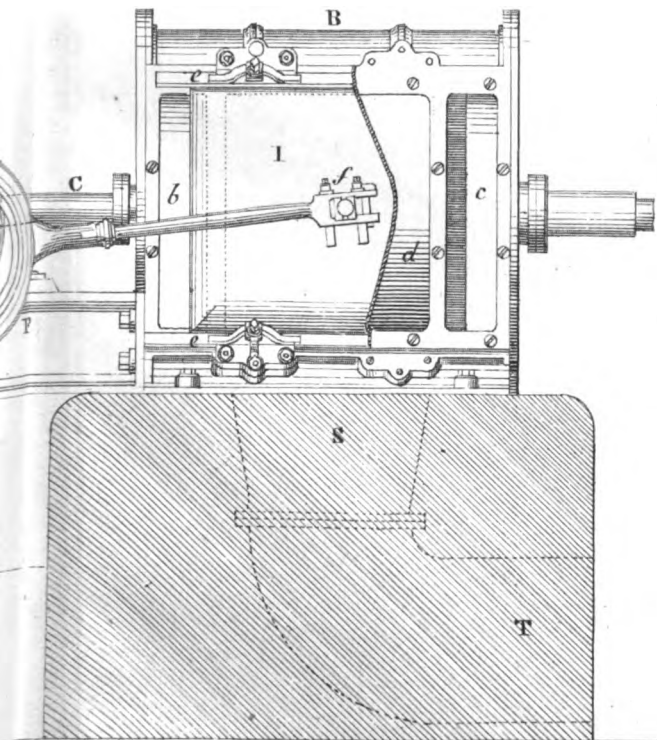
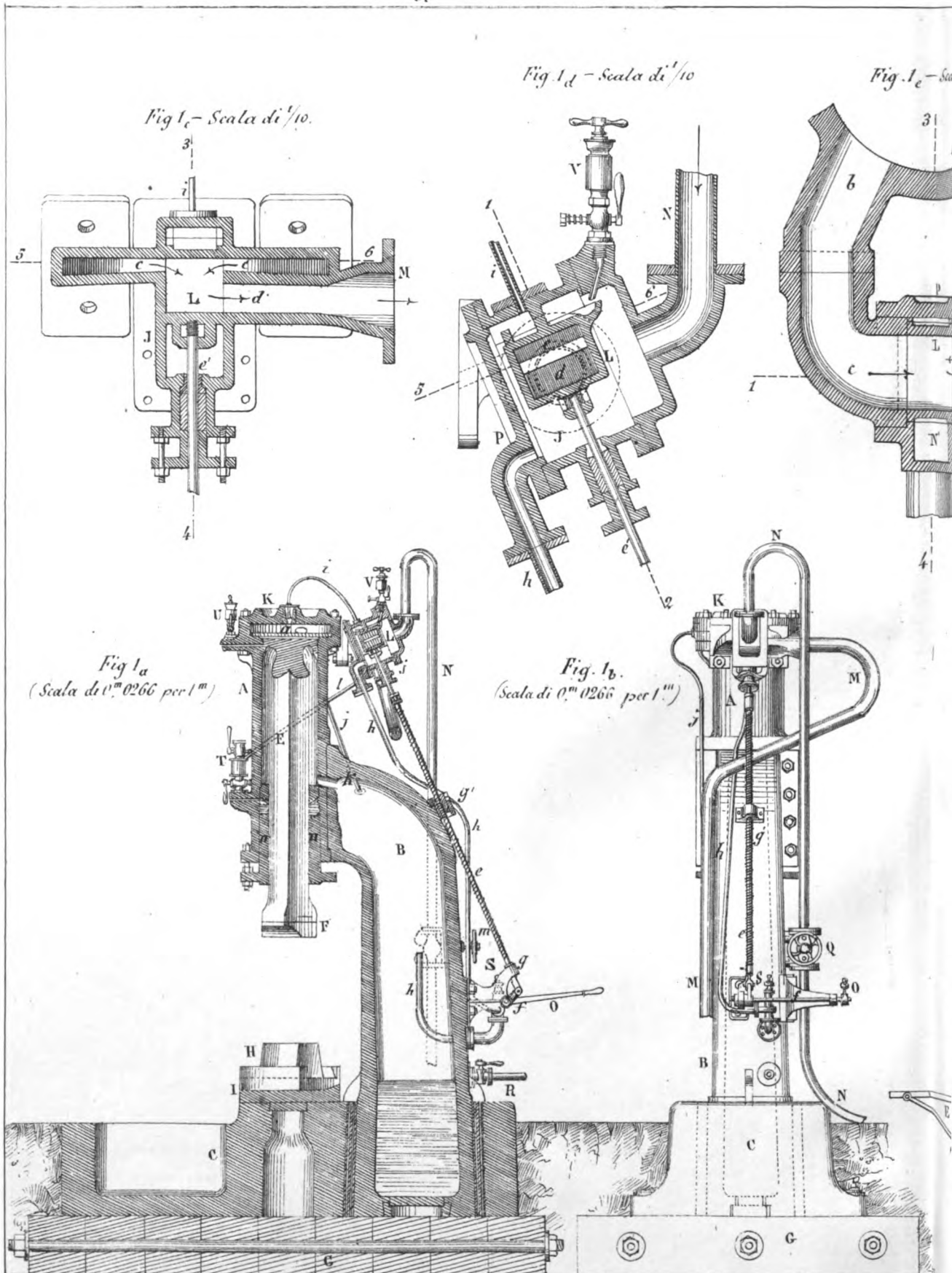

Fig. 2_b - Scala di 1/25.





Francesco Mora dis

Lit. P. Briola Via S. Francesco

-Scala di 1/10

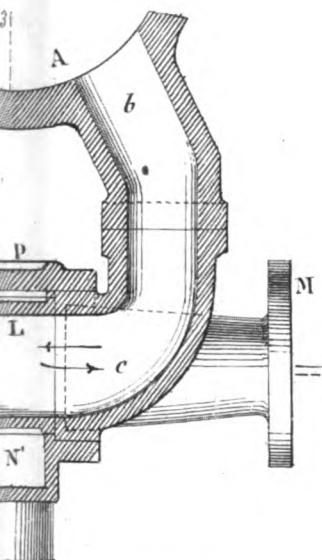

Fig. 1 - Scala 1/5

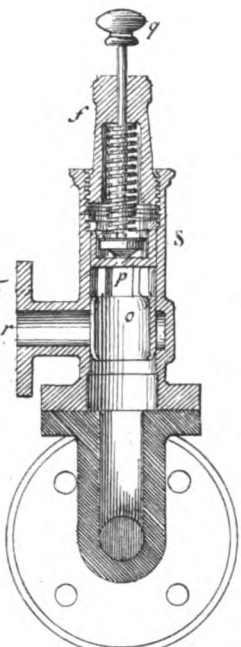

Fig. 2 - Scala di 1/40

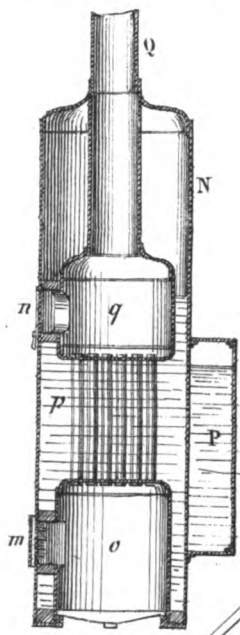

Fig. 2a - Scala di 1/40

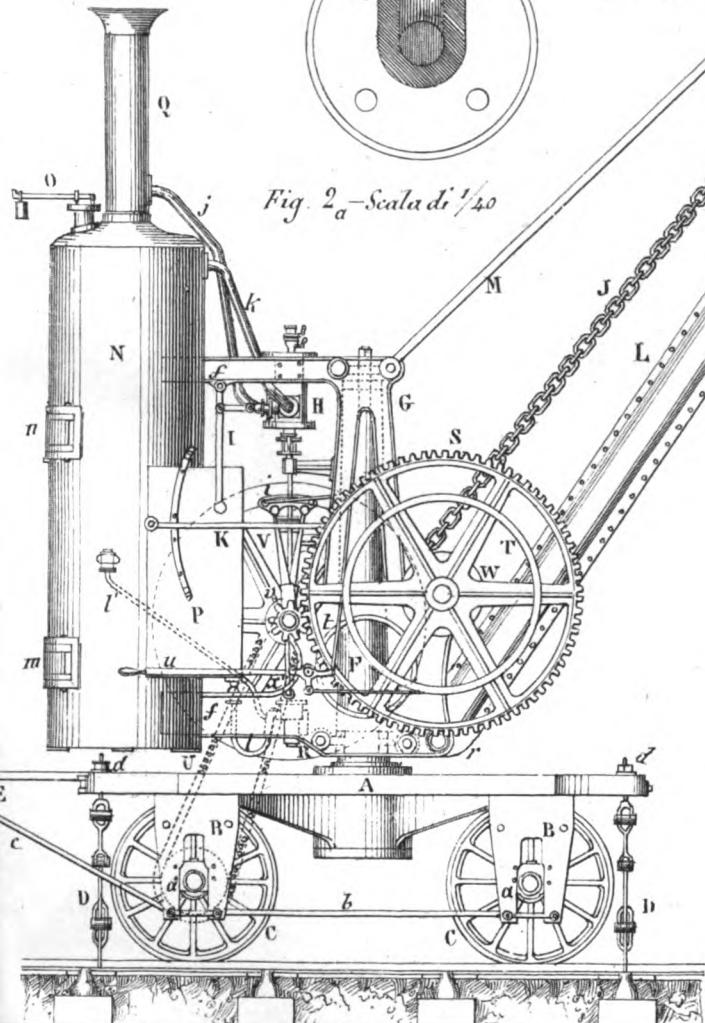
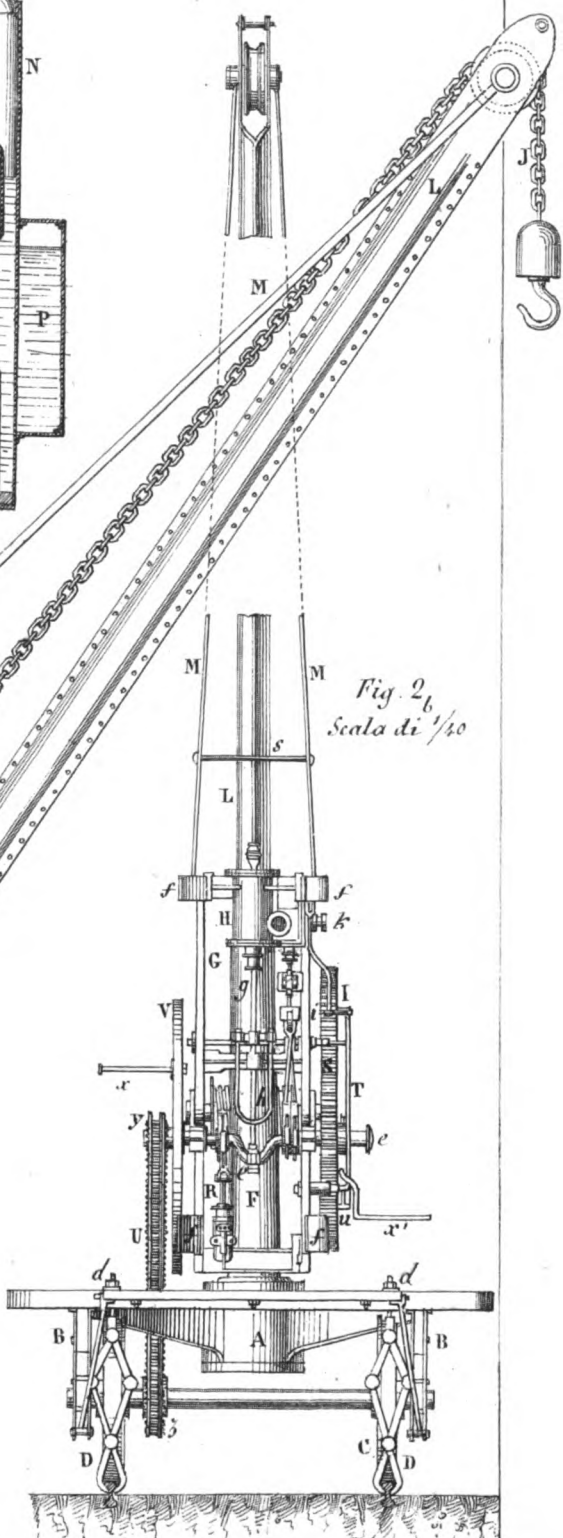

Fig. 2b - Scala di 1/40



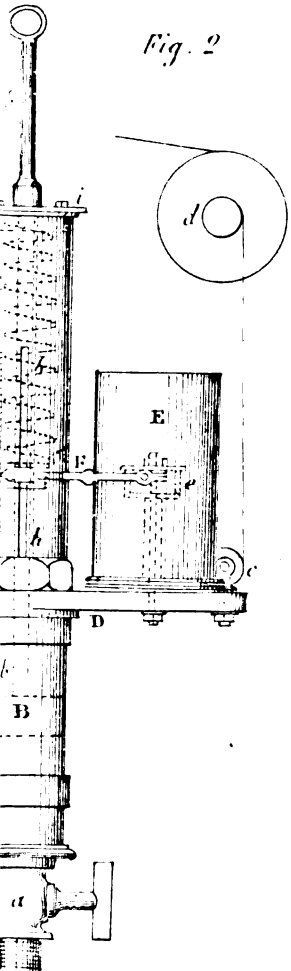

Fig. 2

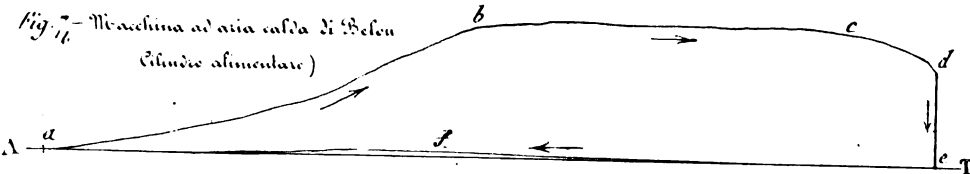
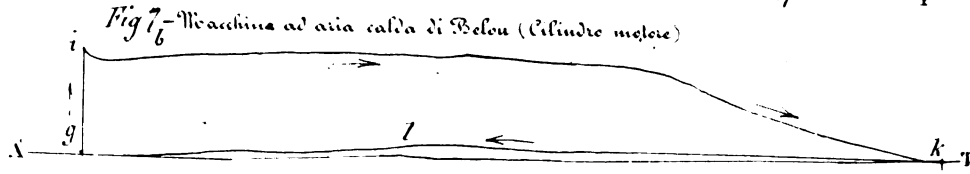
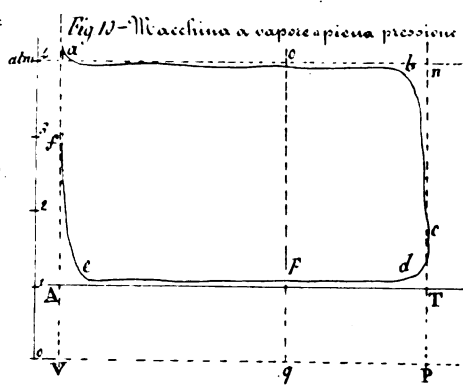
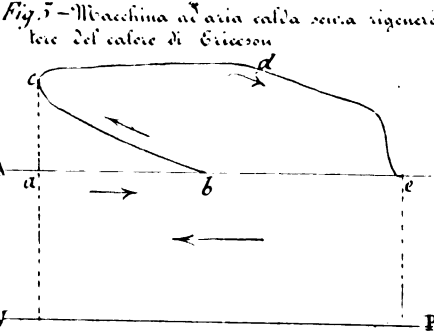
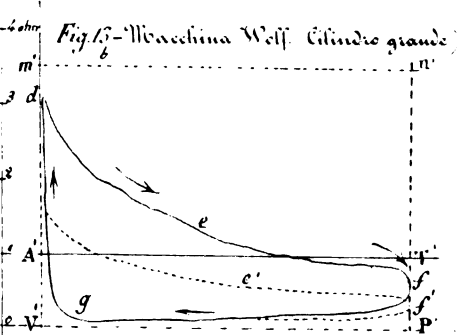
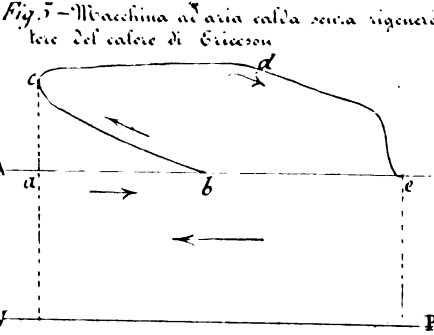
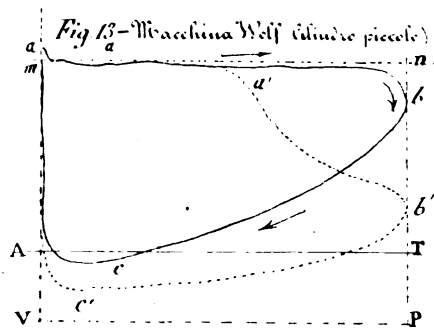

Fig. 9 - Macchina a gas di Hugon

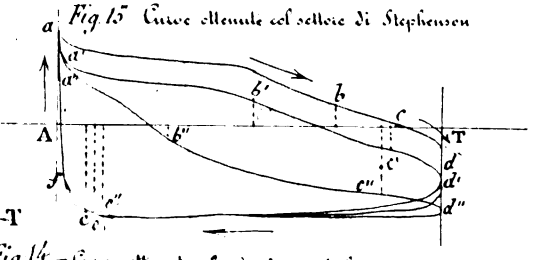
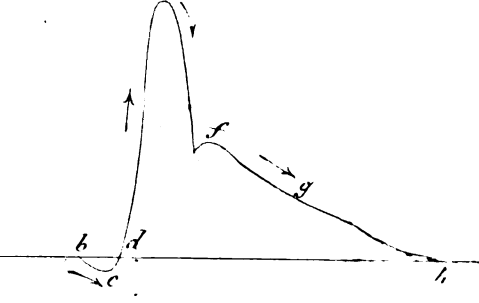

Fig. 6 - Macchina ad aria calda di Lamberau

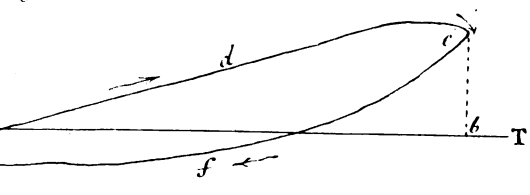
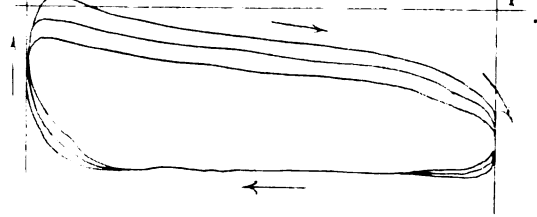
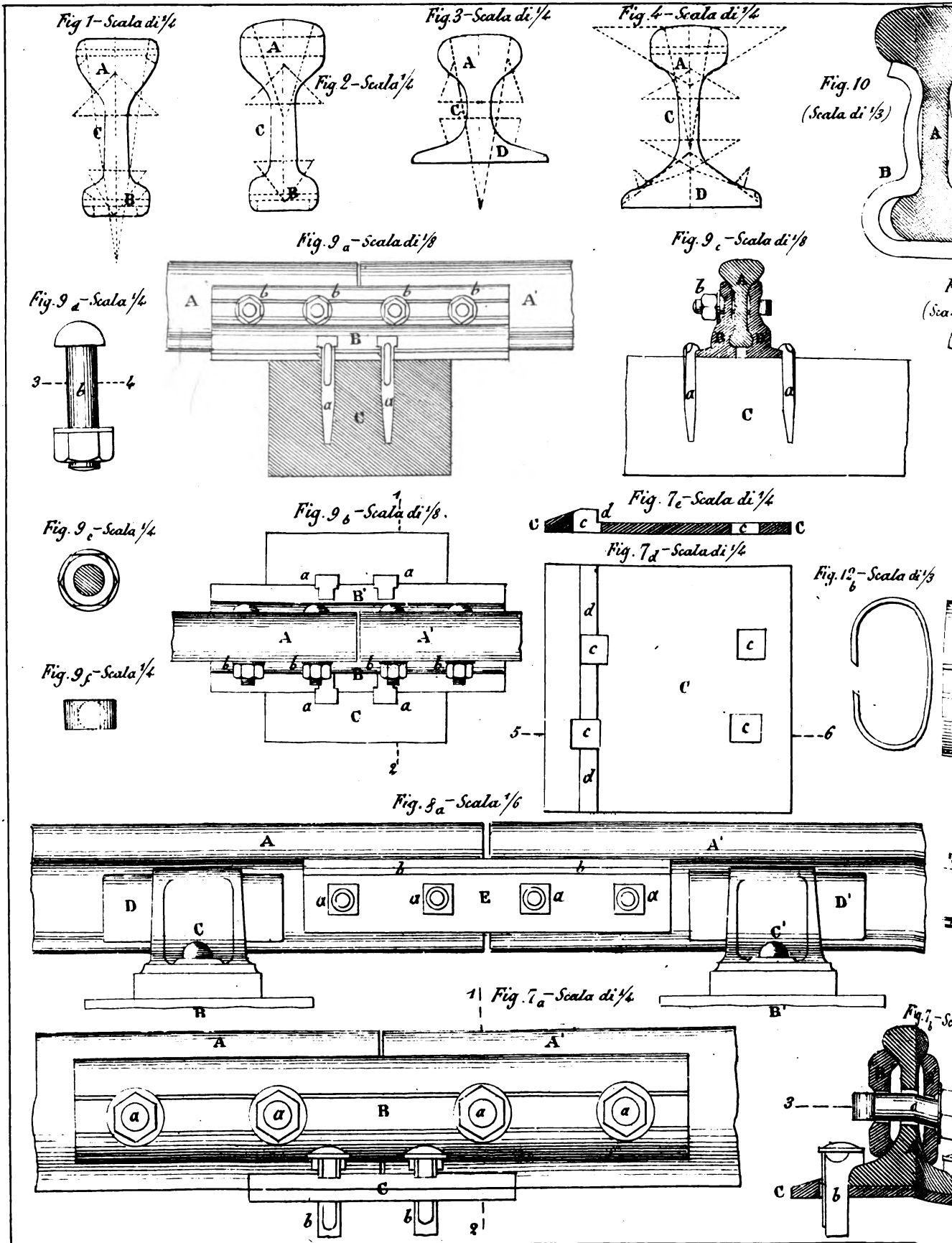
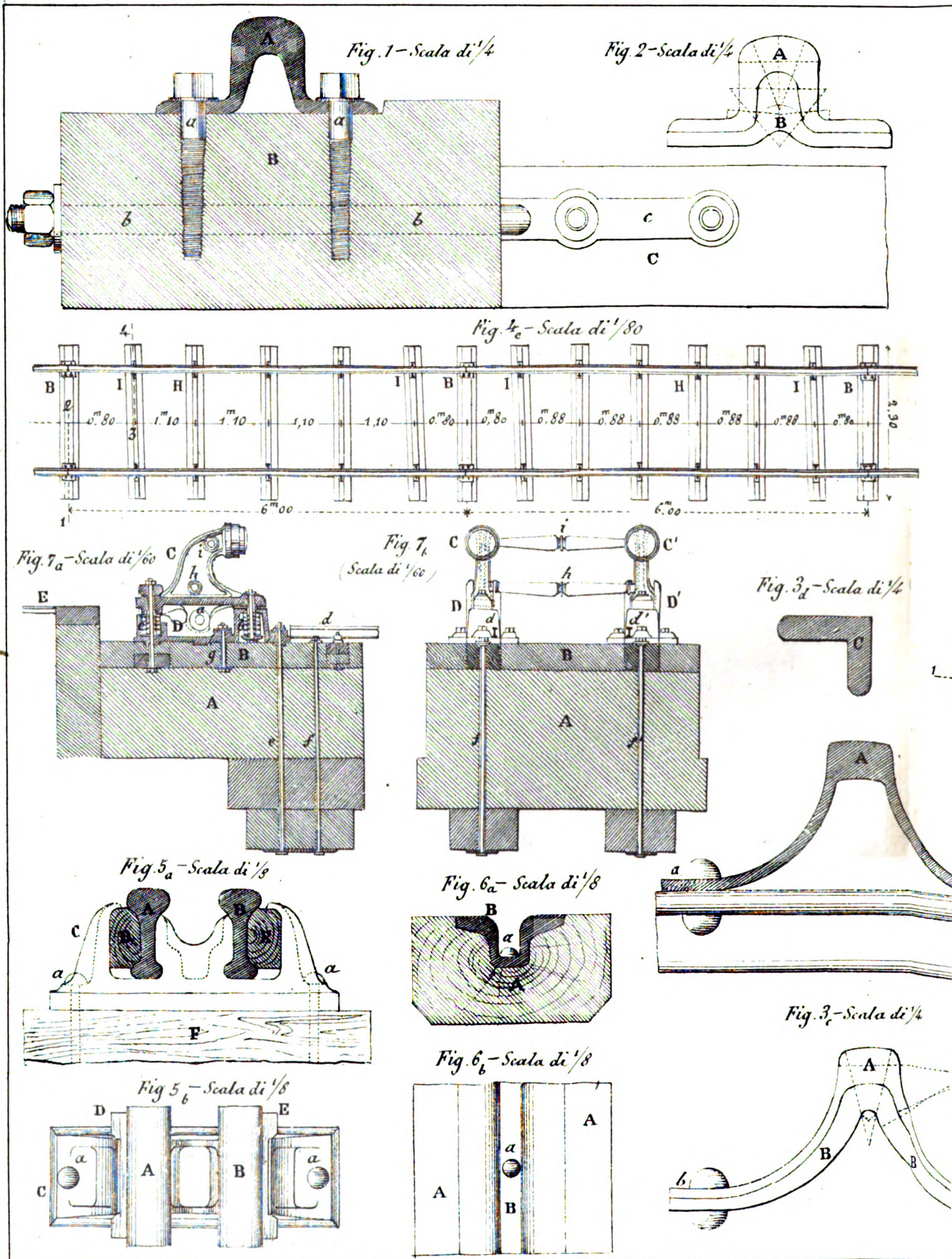

Fig. 14 - Curve ottenute chiudendo parzialmente la valvola di presa del vapore







Magnaghi Giuseppe dis.

Lil P Briola Via S Francesco d

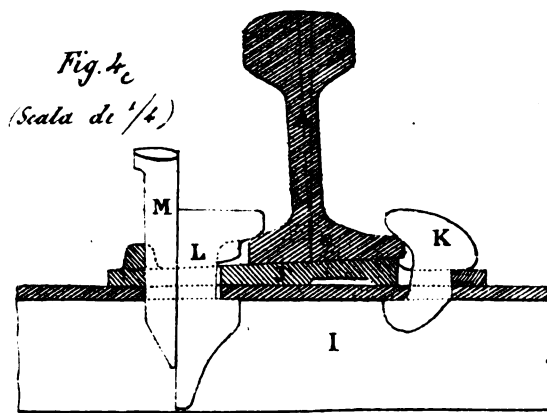
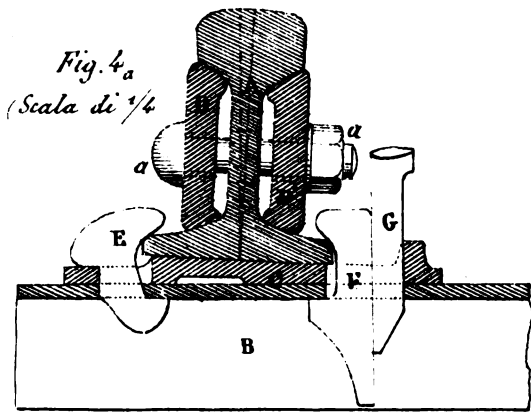

Fig. 4_b - Scala di $\frac{1}{4}$

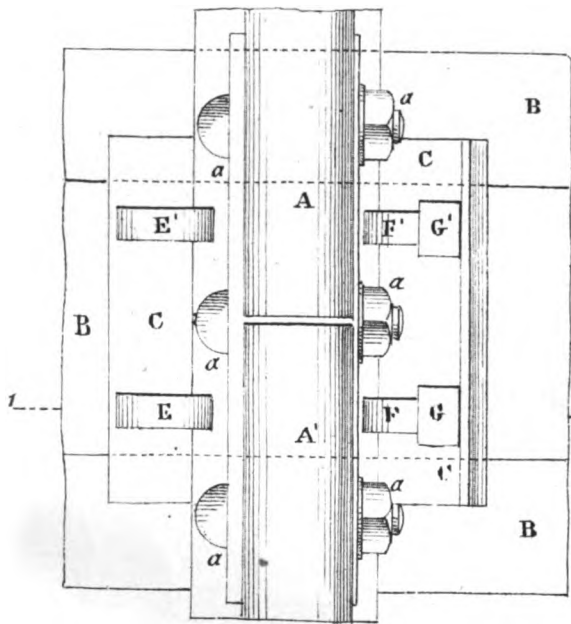

Fig. 4_d - Scala di $\frac{1}{4}$

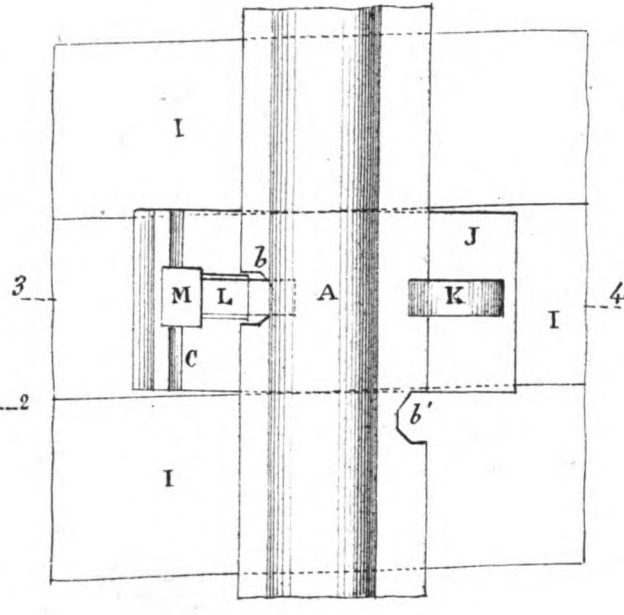

Fig. 3_a - Scala di $\frac{1}{4}$

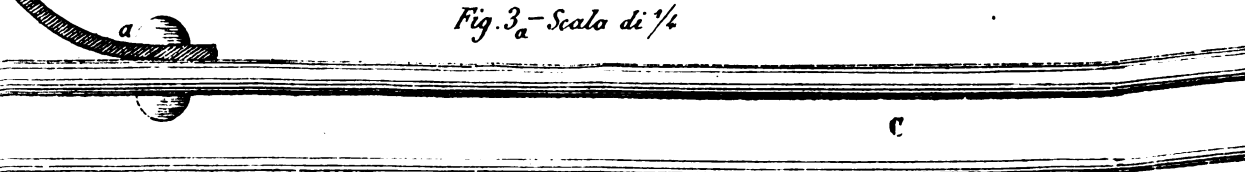

Fig. 3_b - Scala di $\frac{1}{4}$

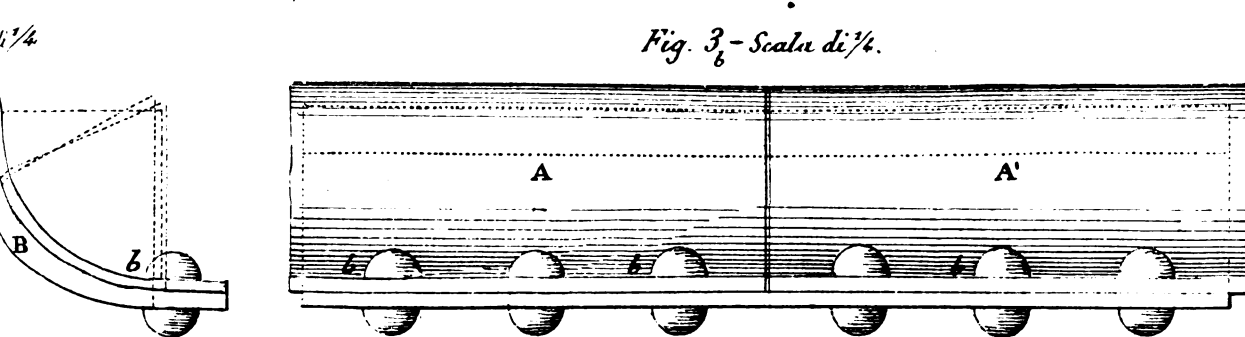

Fig. 1_a - Scala di 1/40

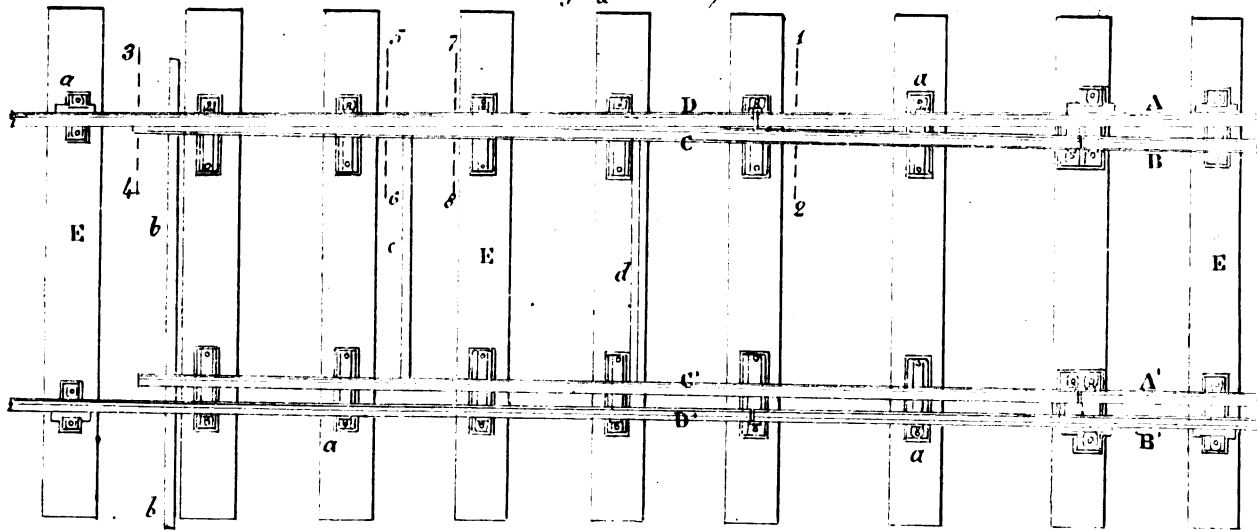

Fig. 6 - Scala di 1/200

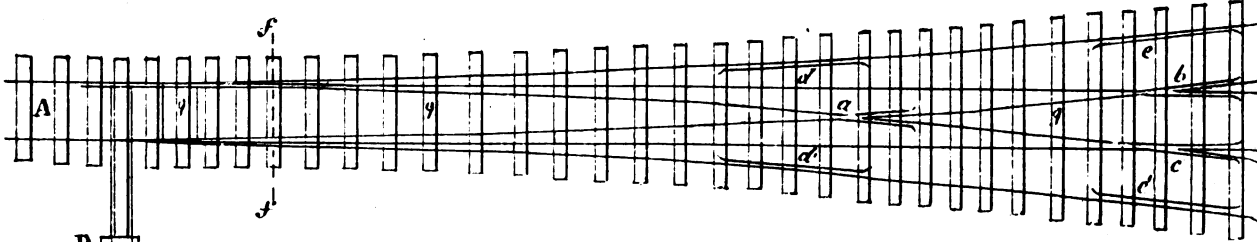

Fig. 4_a - Scala di 1/33

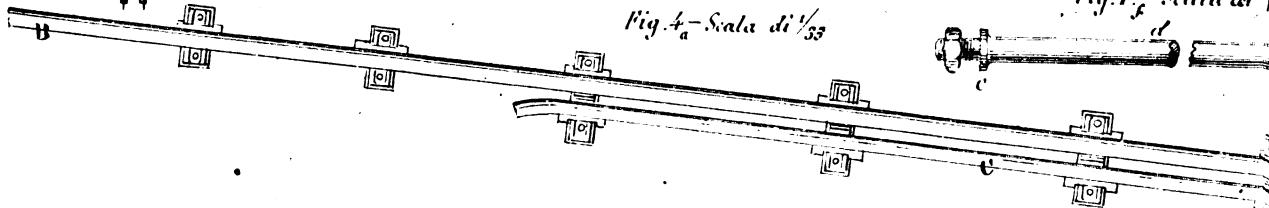

Fig. 1_b - Scala di 1/40

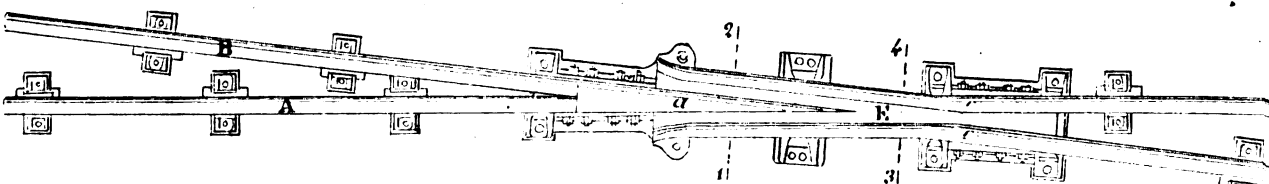
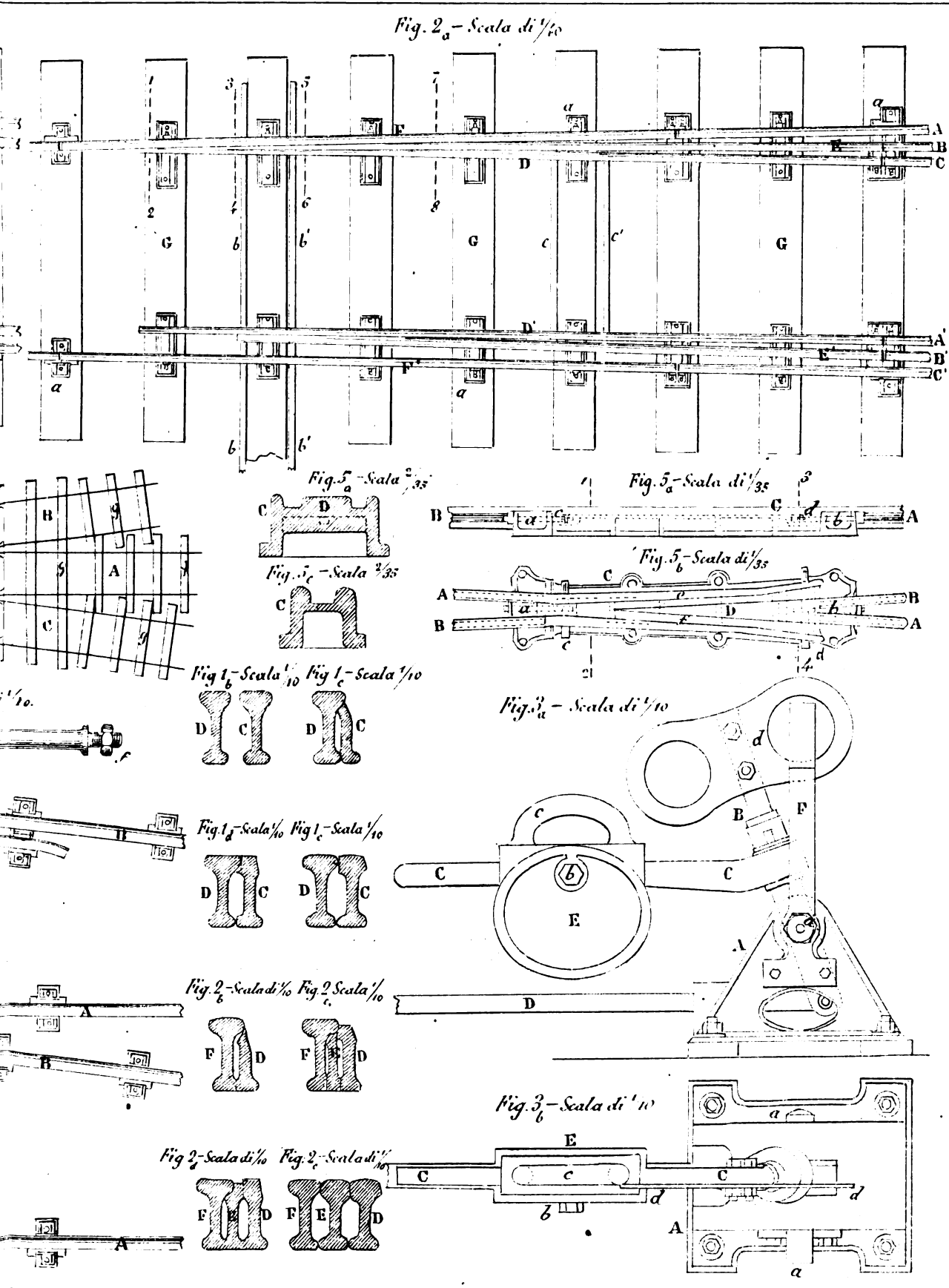

Fig. 4_b - Scala 2/33



Fig. 4_c - Scala 2/33





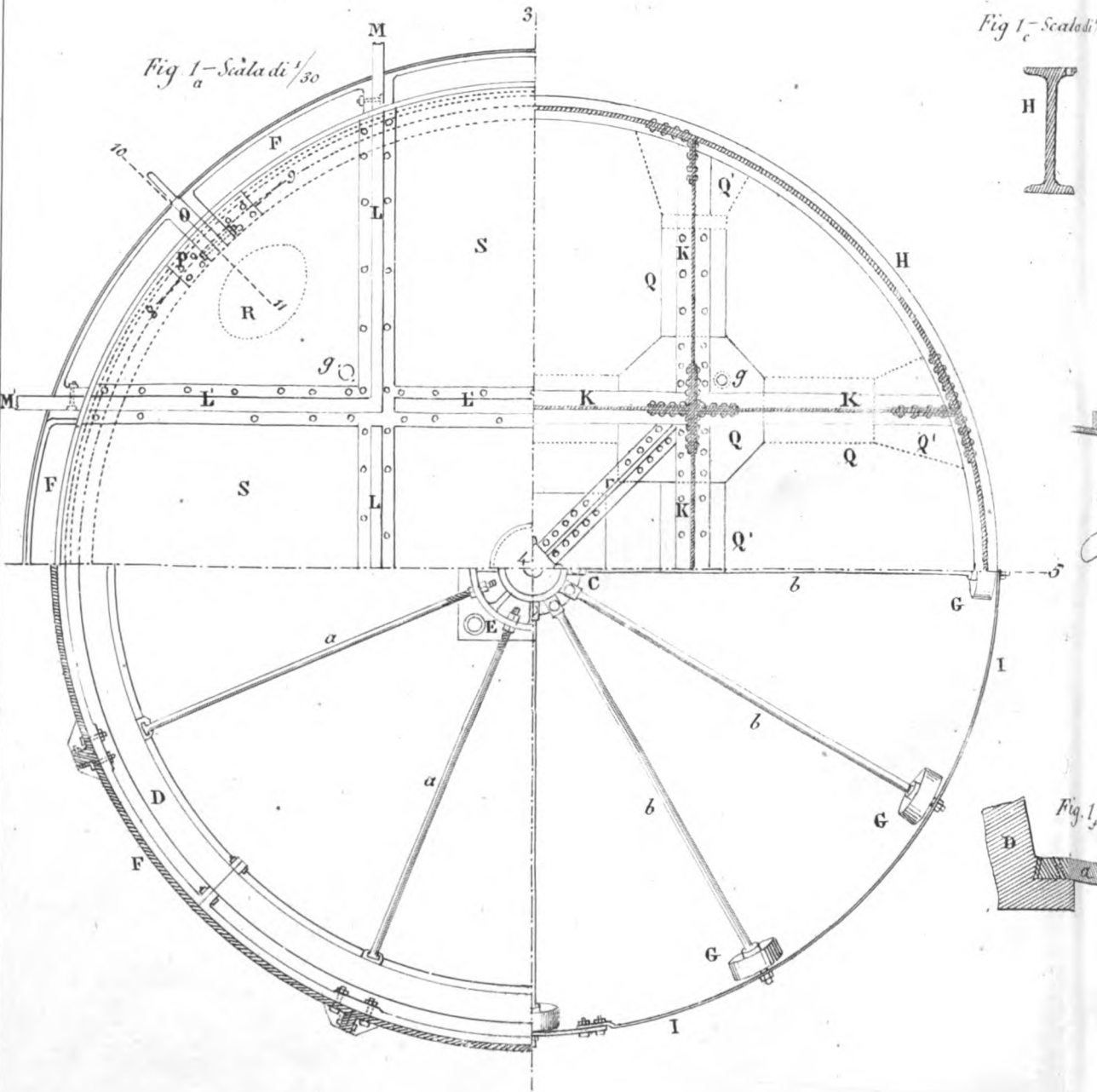
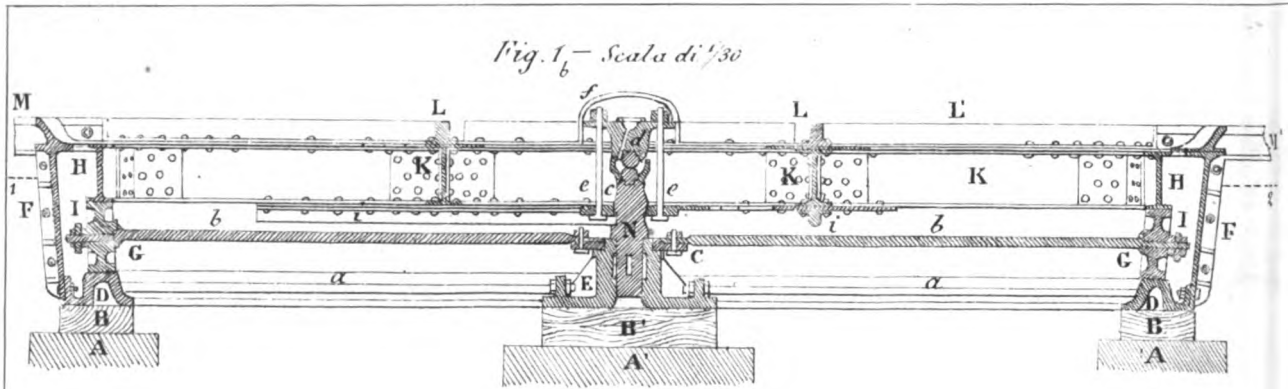

Fig. 1_c - Scala di 1/2.



Fig. 1_d - Scala di 1/2.

Fig. 1_e - Scala di 1/2.

Fig. 1_f - Scala di 1/2.

Piovano Luigi dis.

Lit. P. Briola Via S. Francesco

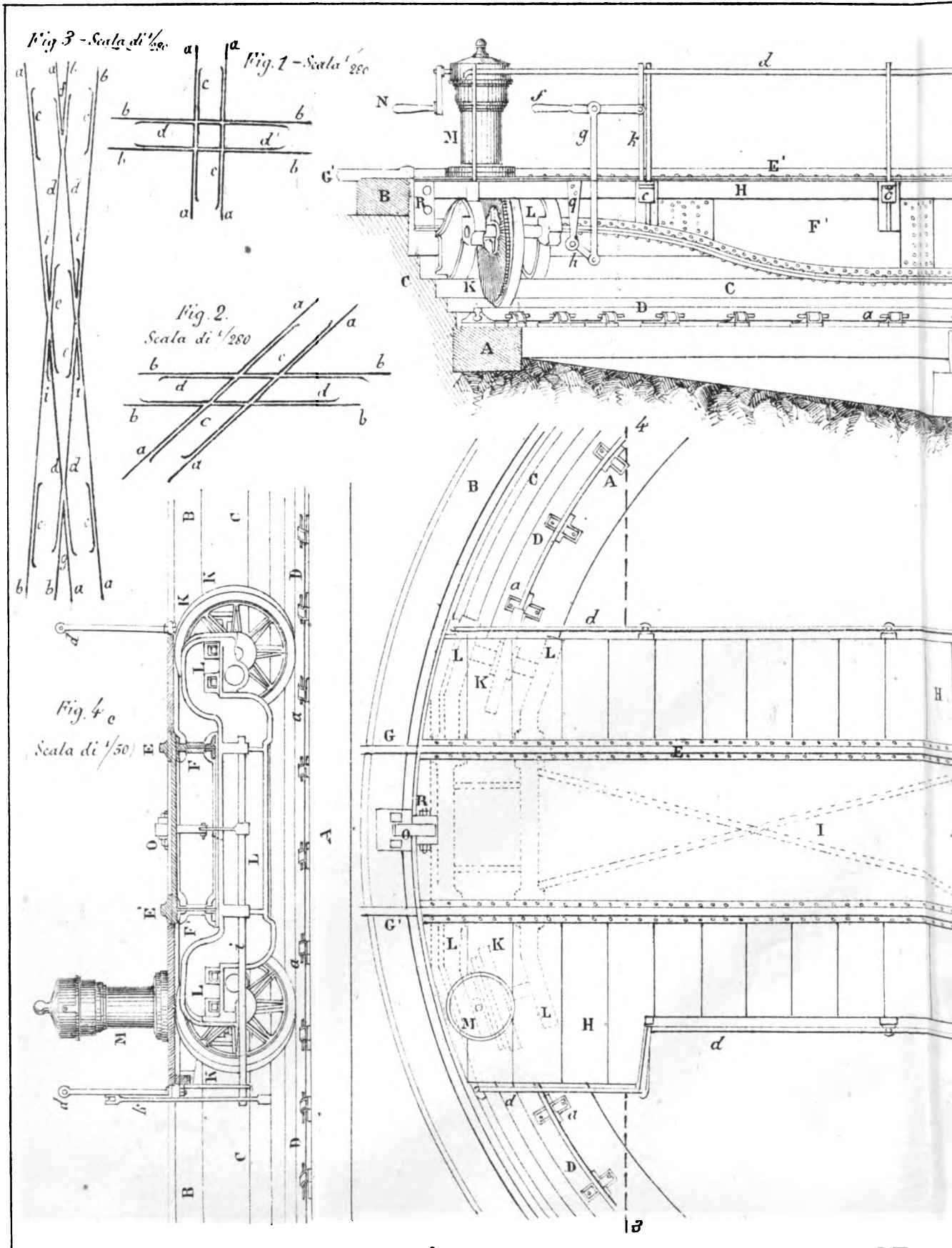

Fig. 4_b - Scala di 1/50

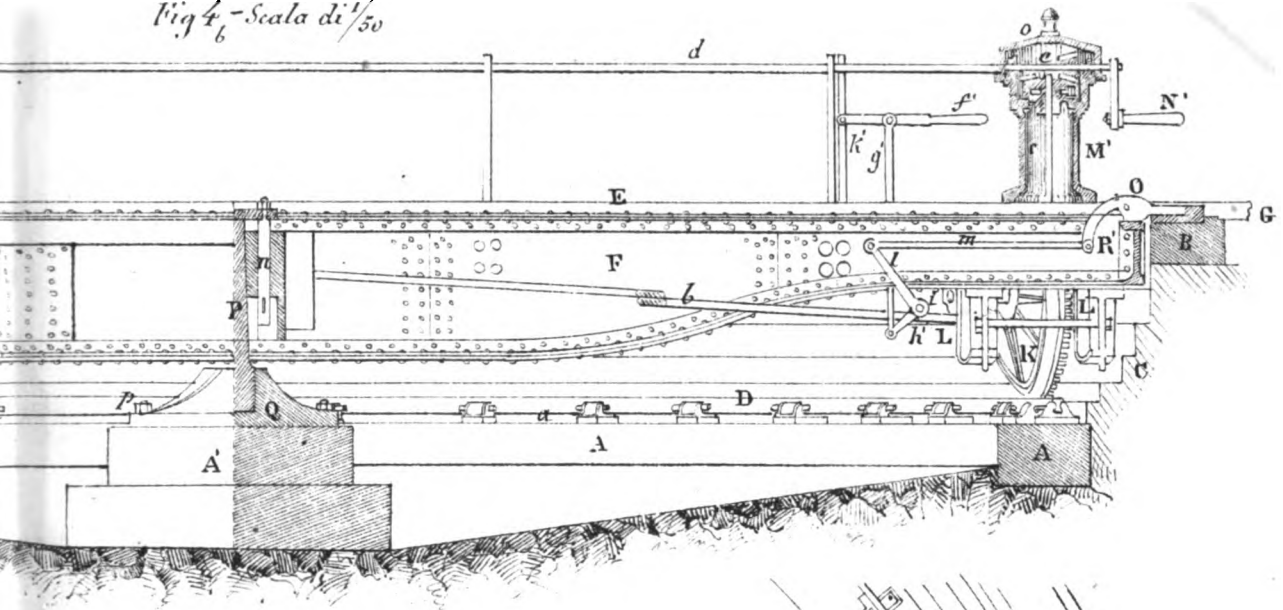
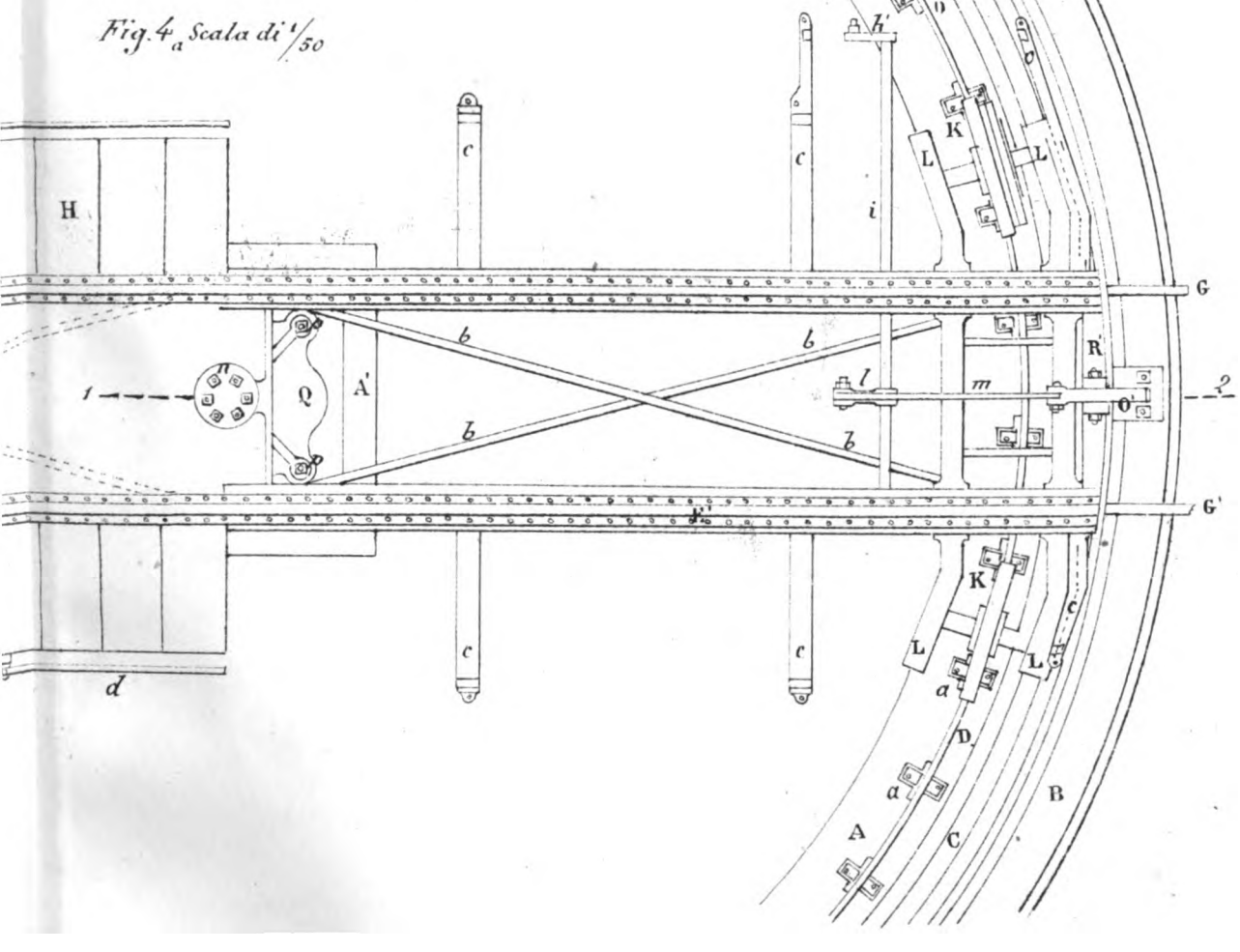
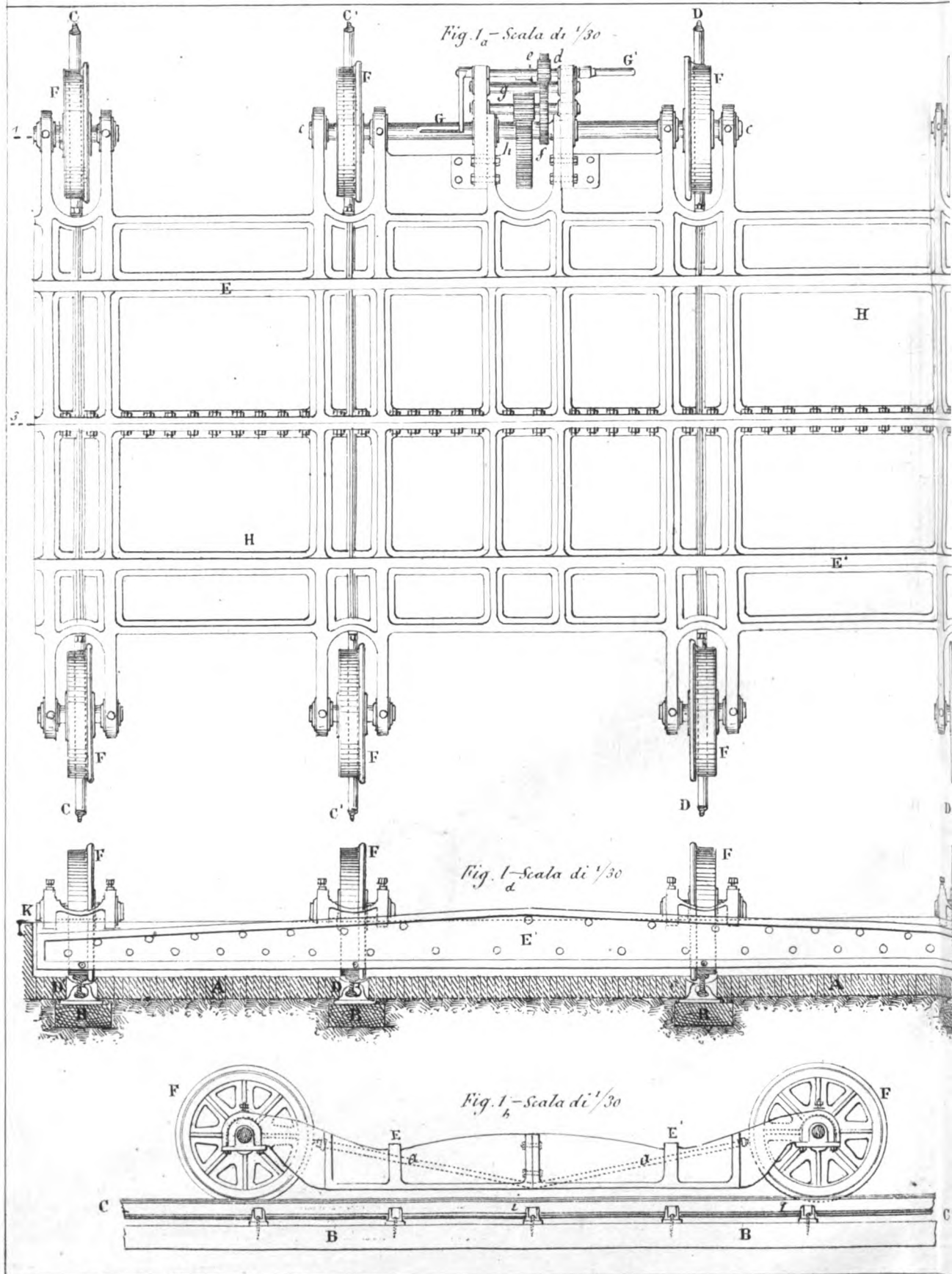

Fig. 4_a - Scala di 1/50





Leone Turina dis.

Torino Lit. P. Briola Via S.F.

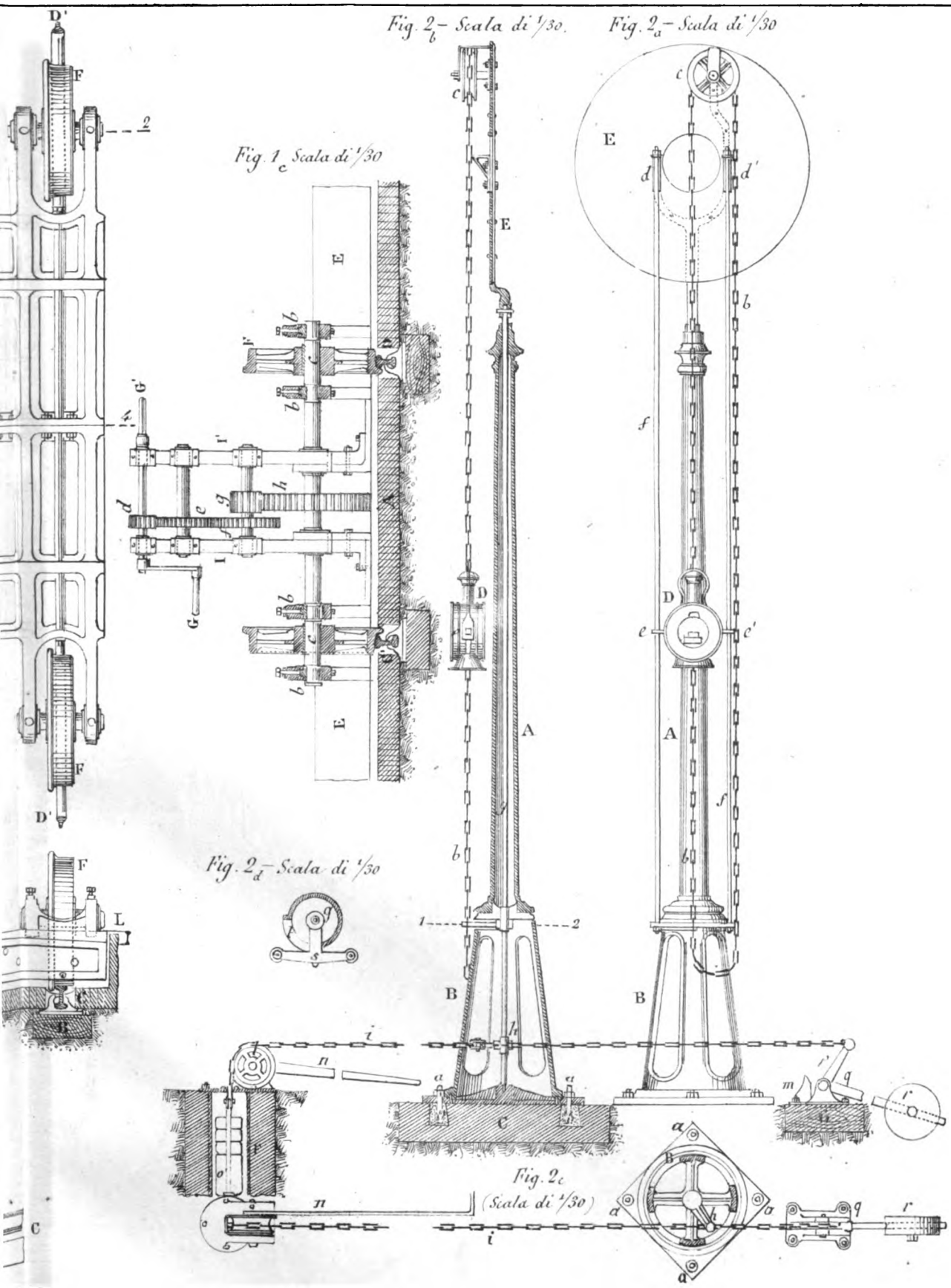

B a s t i a

Scala di 0,0000

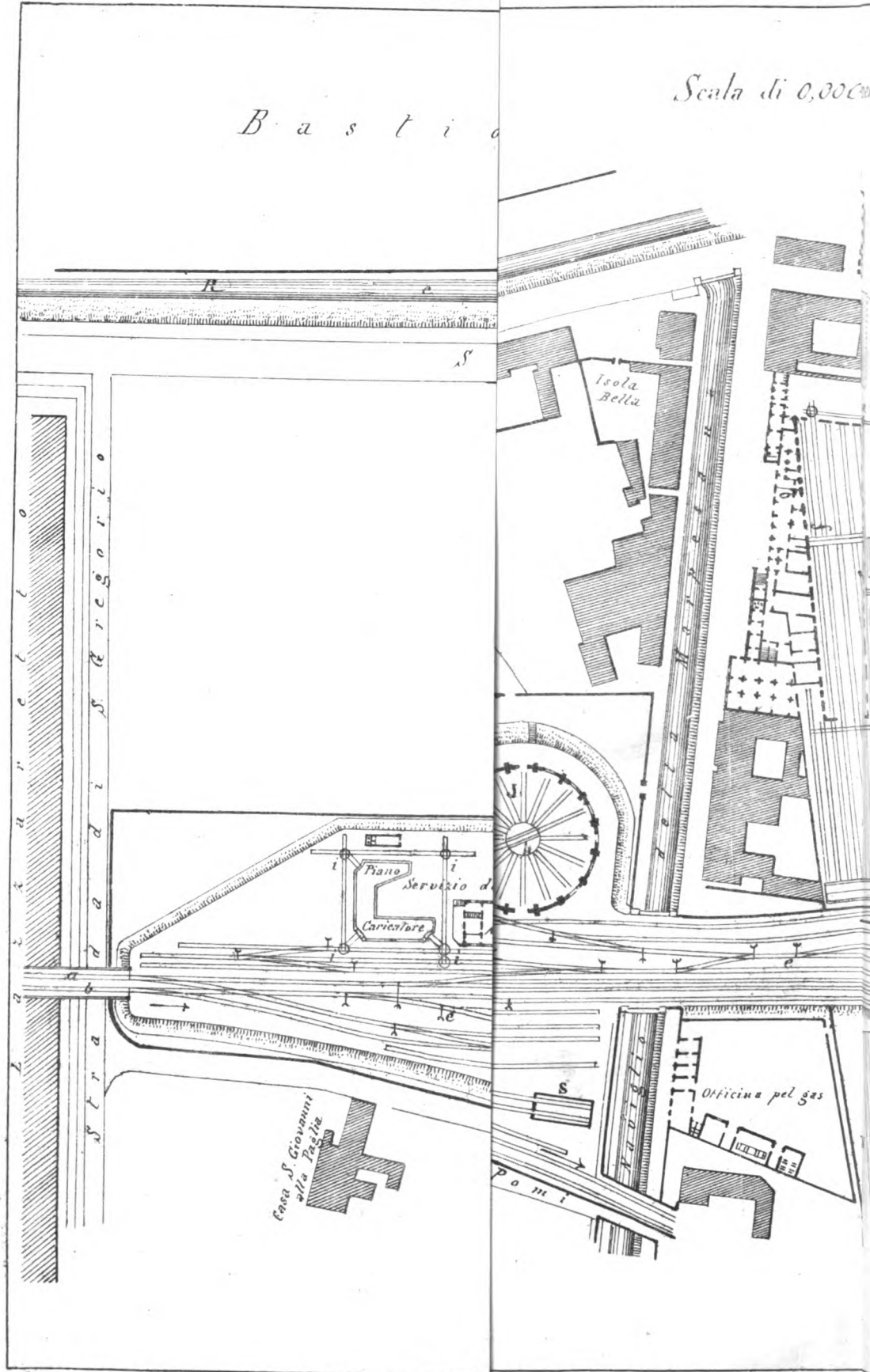

Luigi Polese dis.

Torino Lit P. Briola via S. Francesco

004 per metro

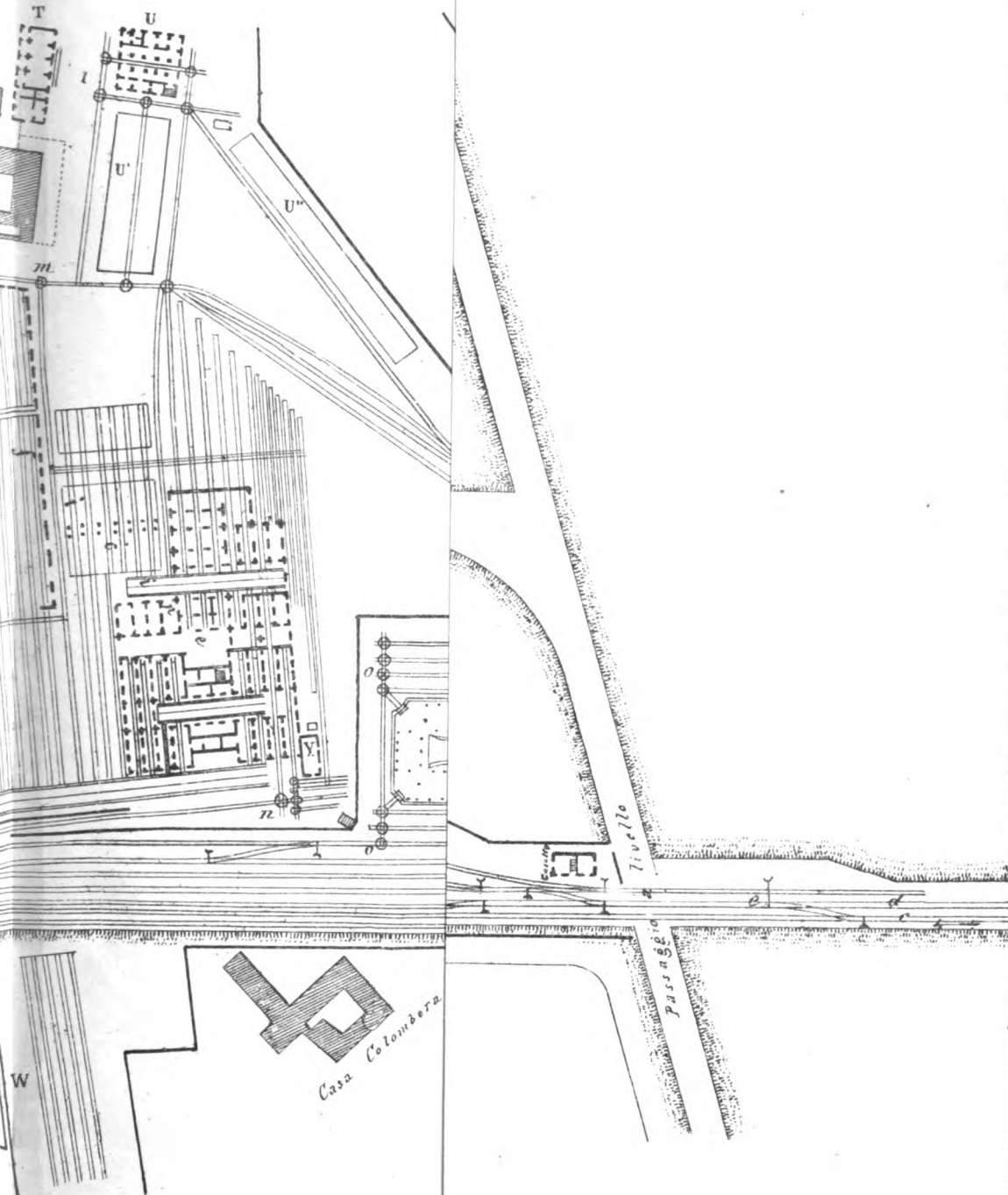

Fig. 4_a - Scala di 1/8

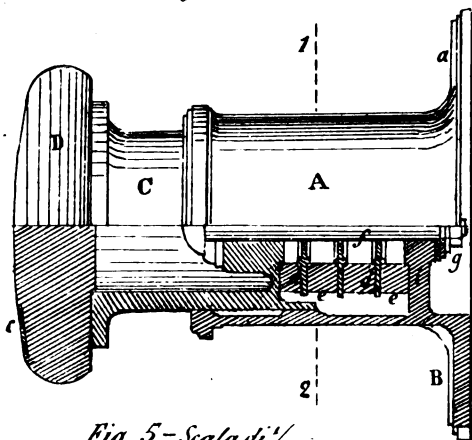

Fig. 4_b - Scala di 1/8

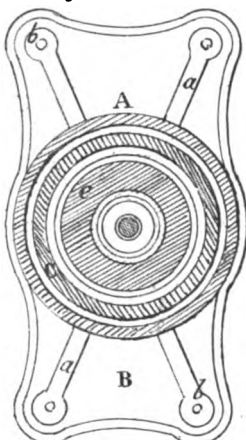

Fig. 6 - Scala di 1/8

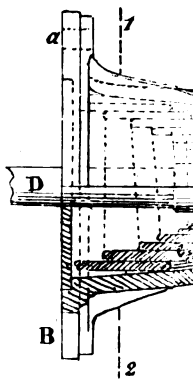
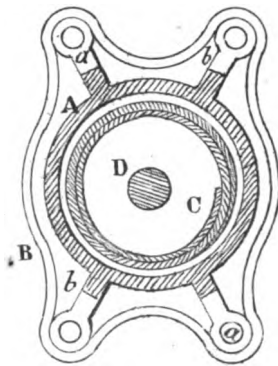

Fig. 5_b - Scala di 1/6

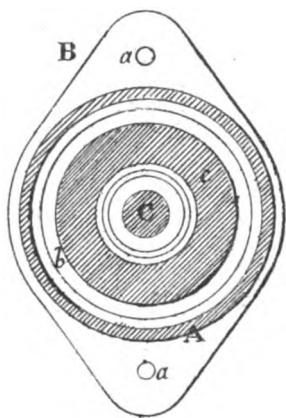

Fig. 5_a - Scala di 1/6

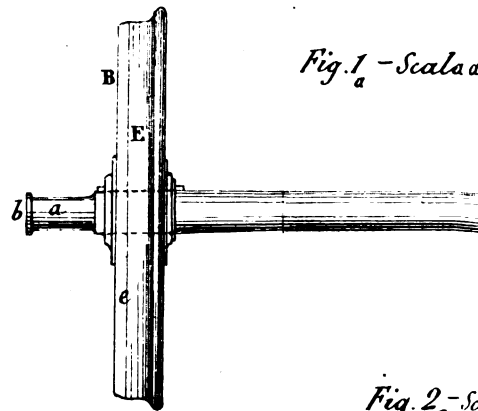
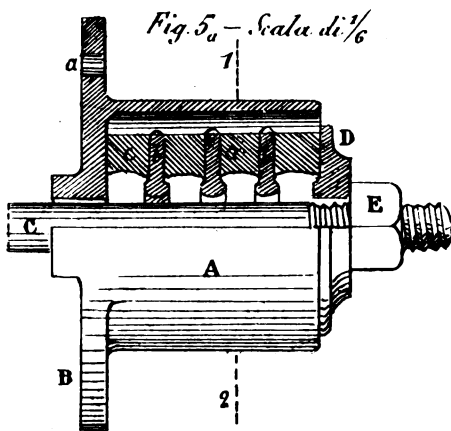

Fig. 1_a - Scala di 1/8

Fig. 2_a - Scala di 1/8

Fig. 2_c - Scala 1/5

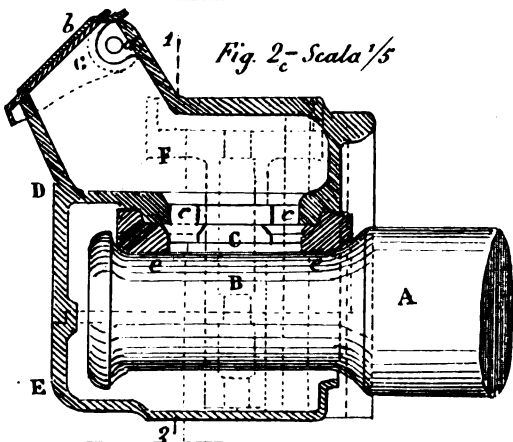
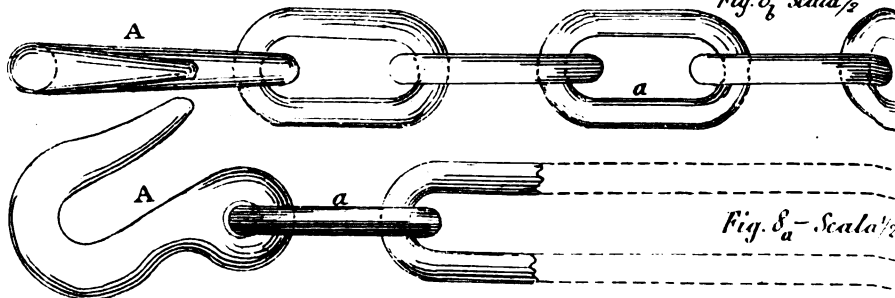
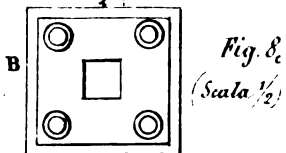
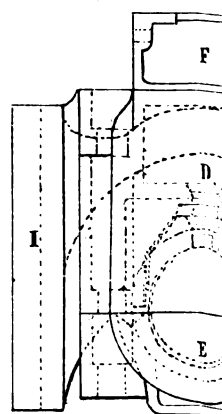
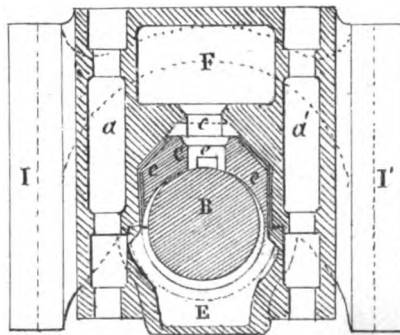

Fig. 2_d - Scala 1/5



T. Biagio dis.

Torino Int P. Briola Vis

Fig. 6_a - Scala di 1/8

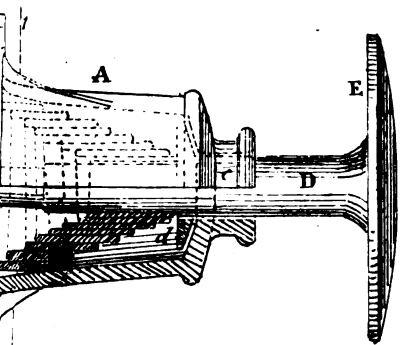

Fig. 7_a - Scala di 1/10

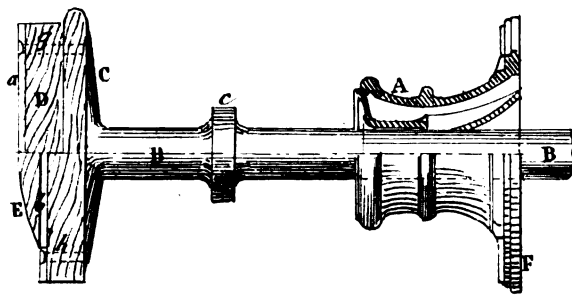

Fig. 7_b - Scala di 1/10

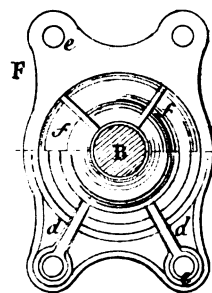

Fig. 1_b - Scala di 1/20

Scala di 1/20

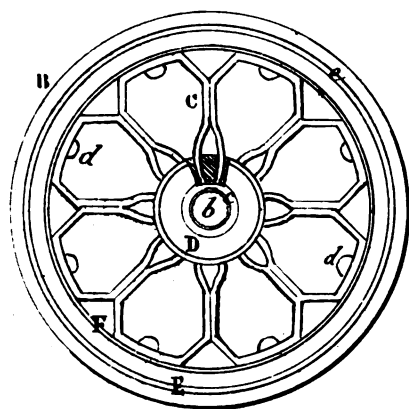
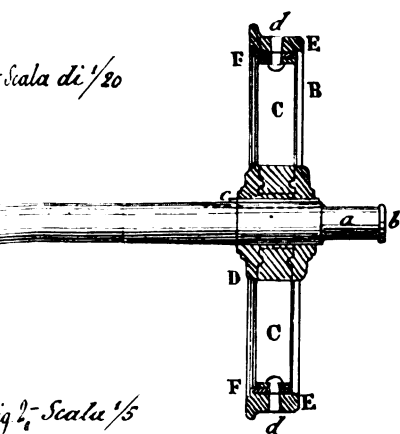

Fig. 7_c - Scala di 1/5

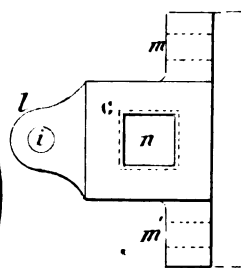
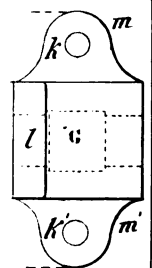

Fig. 7_d - Scala di 1/5



Scala 1/5

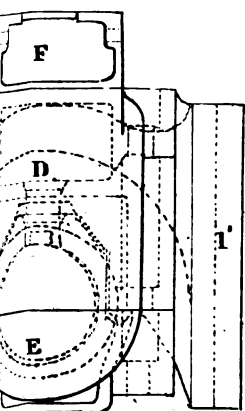

Fig. 2_b - Scala 1/5

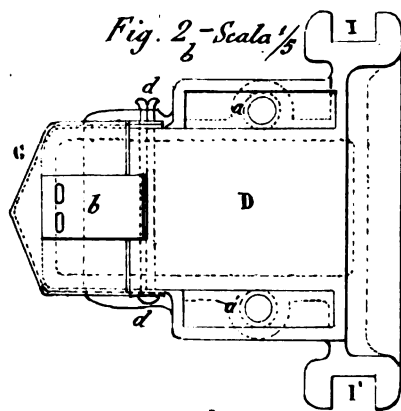

Fig. 3_a - Scala di 1/2

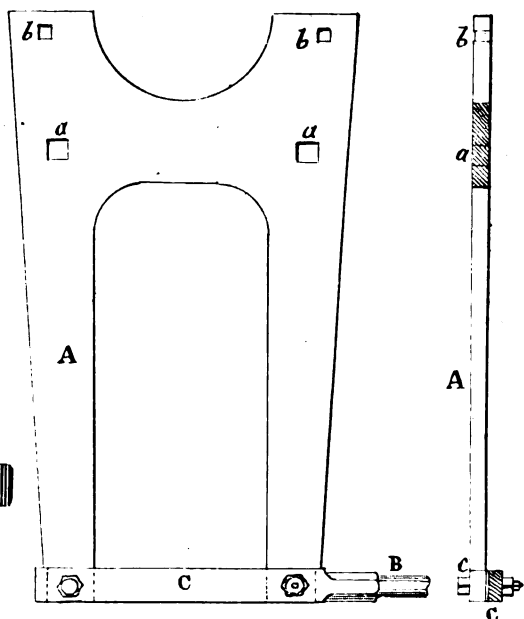
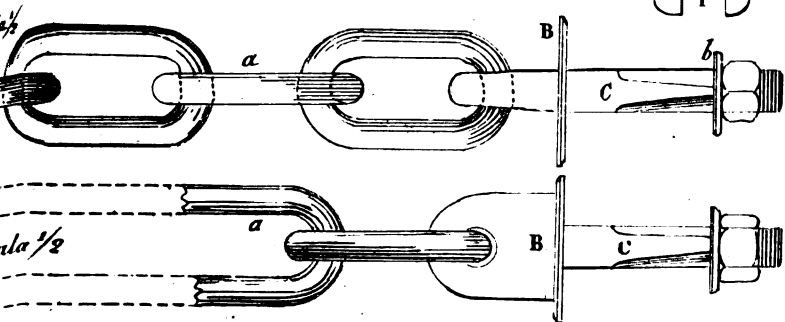

Fig. 3_b - Scala 1/2



Scala 1/2



Fig. 3_c - Scala 1/4

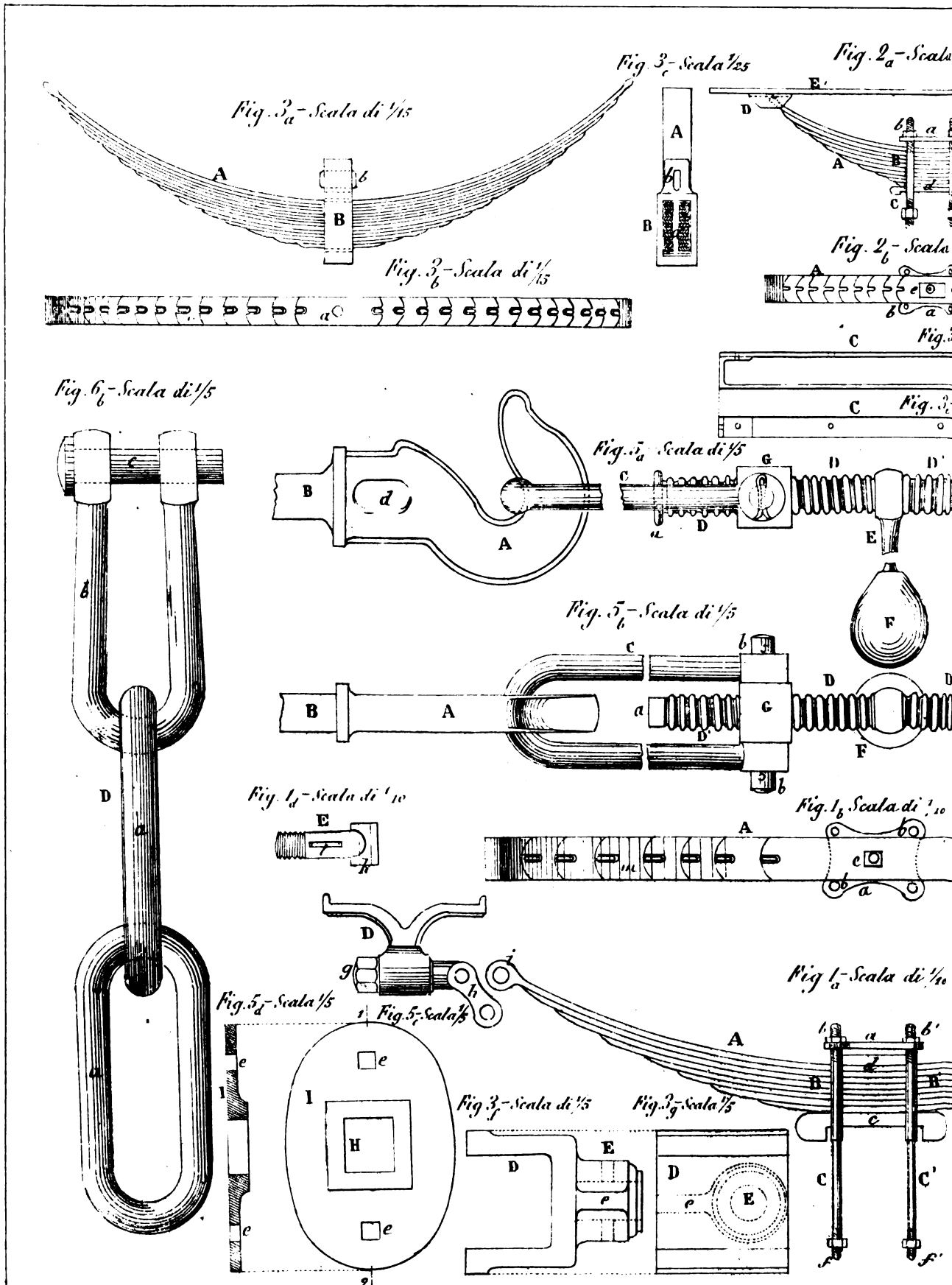

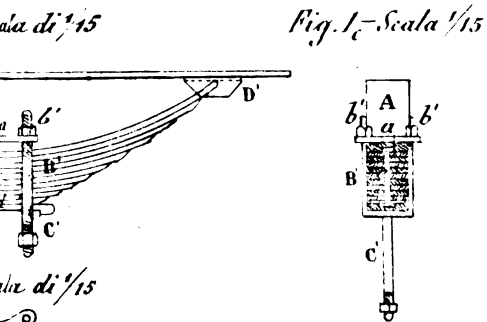

Fig. 1c - Scala $\frac{1}{15}$

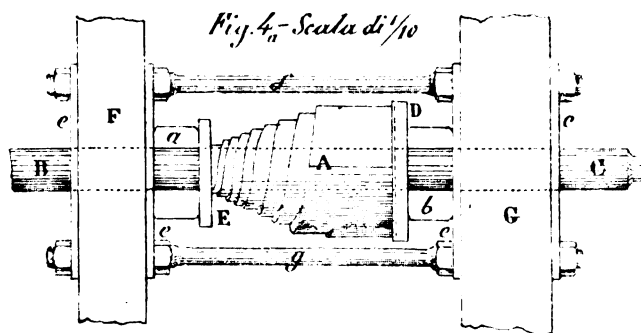
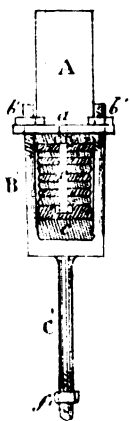
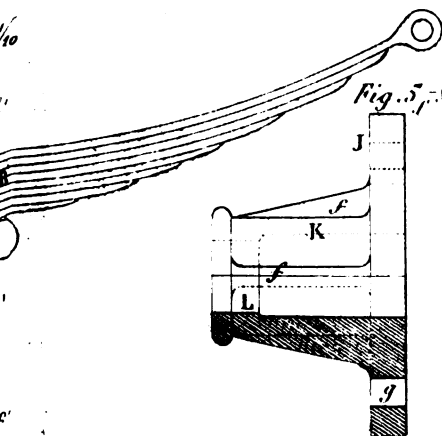
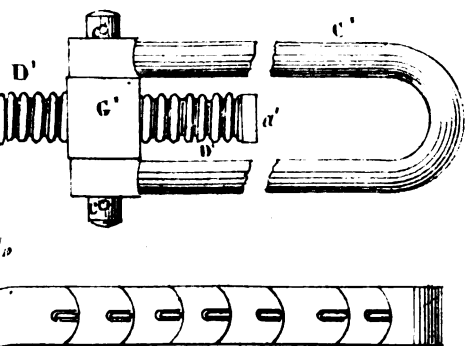
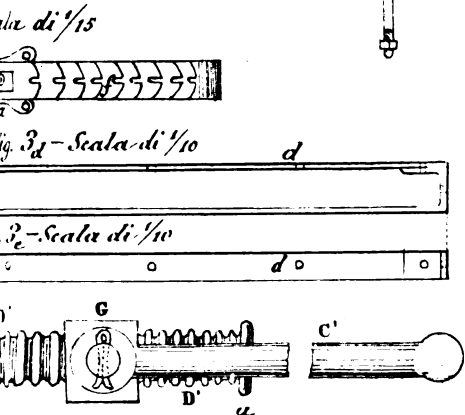

Fig. 4a - Scala di $\frac{1}{10}$

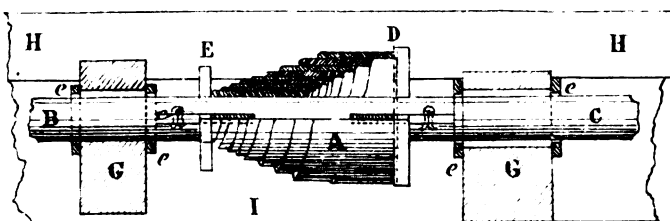

Fig. 6c - Scala di $\frac{1}{5}$

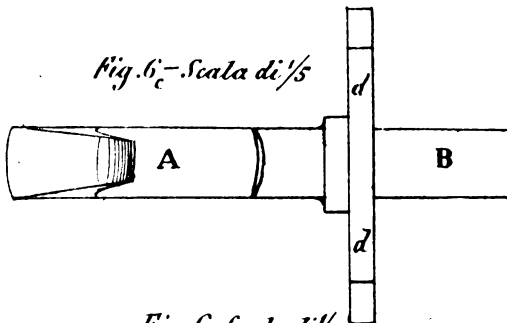

Fig. 6b - Scala di $\frac{1}{5}$

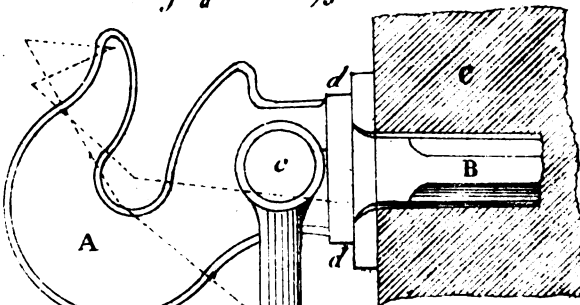

Fig. 5e - Scala di $\frac{1}{5}$

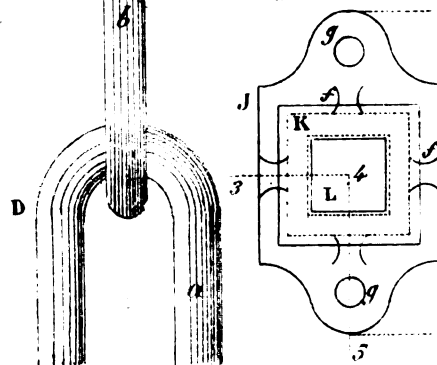

Fig. 1_a - Scala di 0.^m 027 per 1.^m

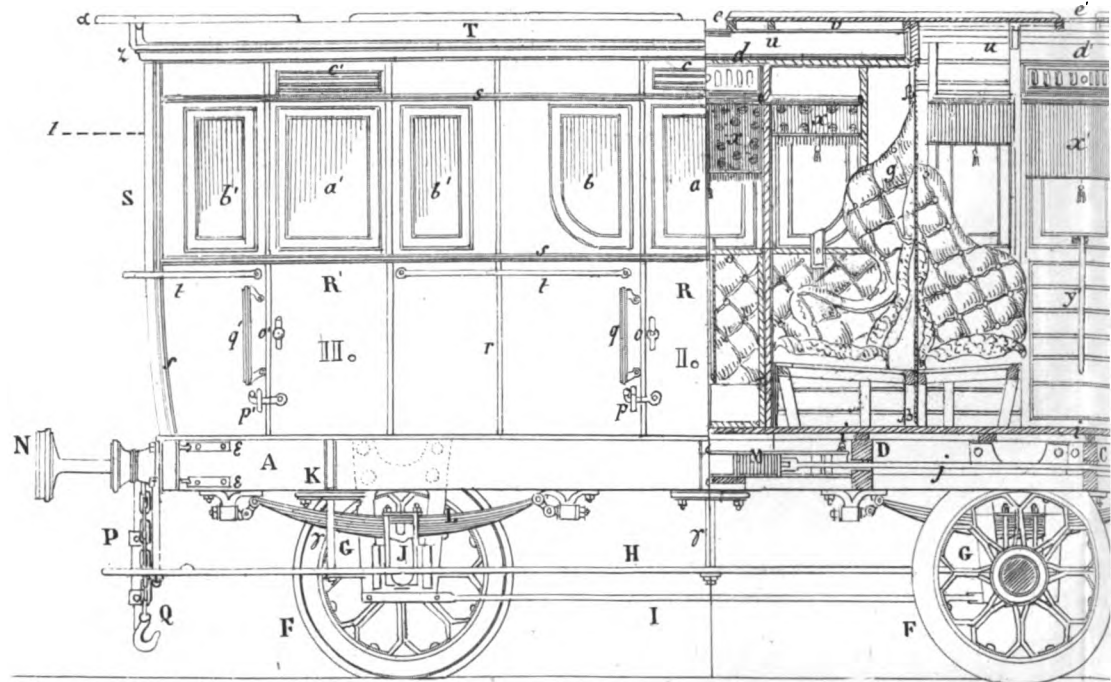

Fig. 1_c - Scala di 0.^m 027 per 1.^m

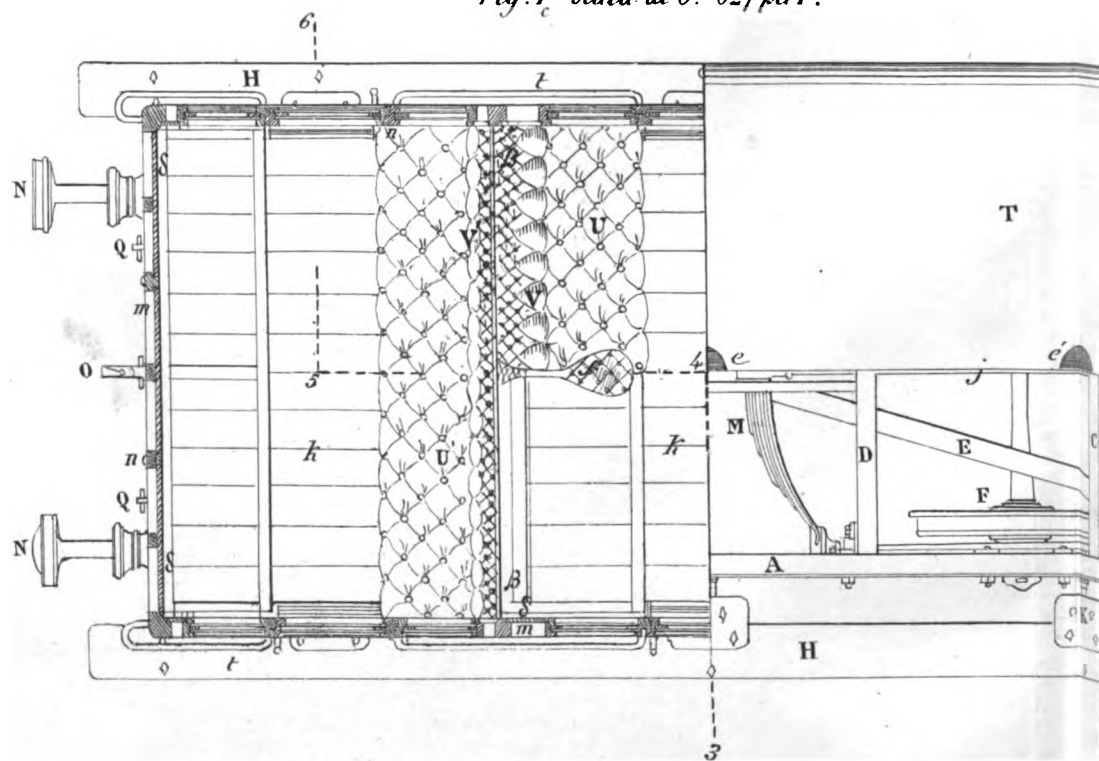

Fig. 1_a - Scala di 0,027 per 1^m

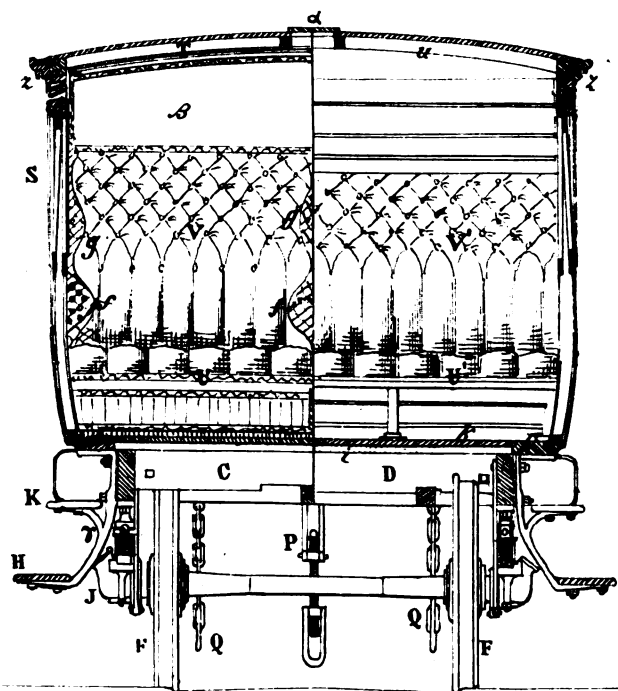
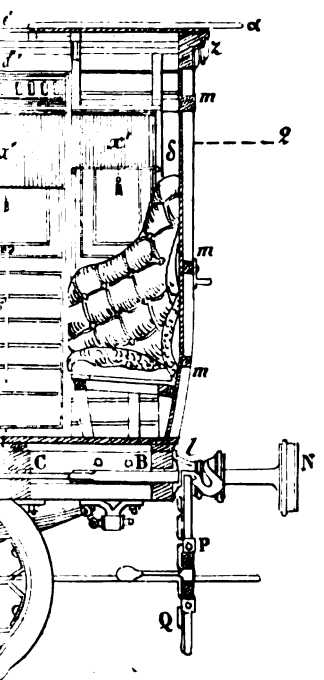

Fig. 1_b - Scala di 0,027 per 1^m

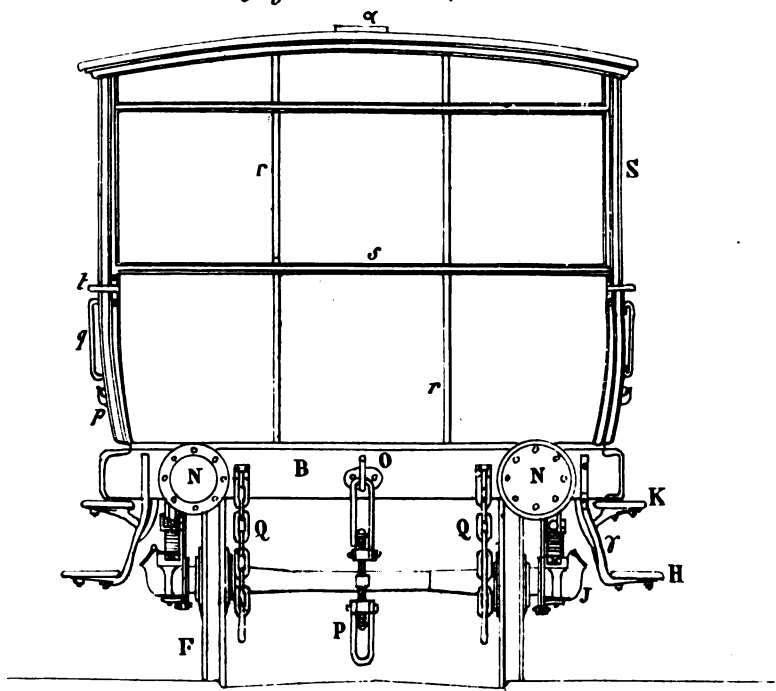
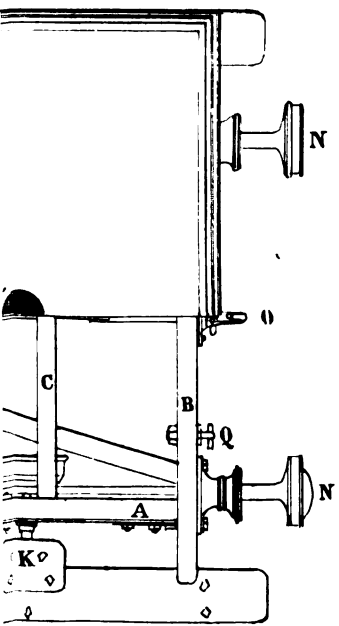

Fig. 1_a - Scala di 0.^m 027 per 1.^m

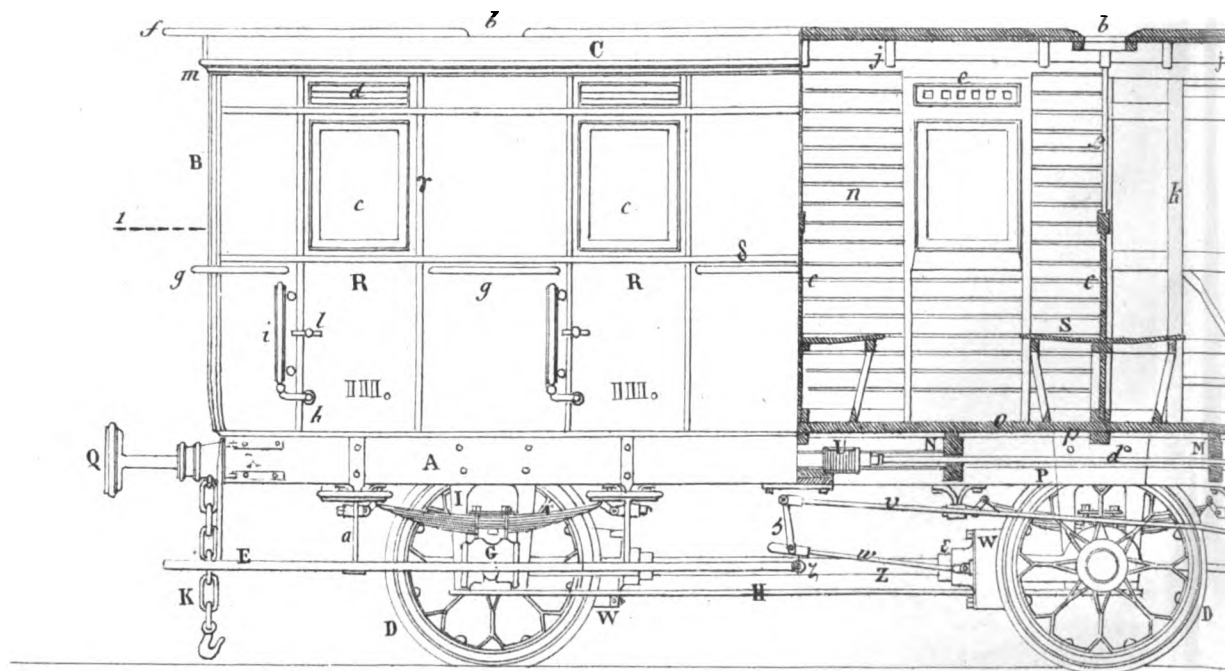
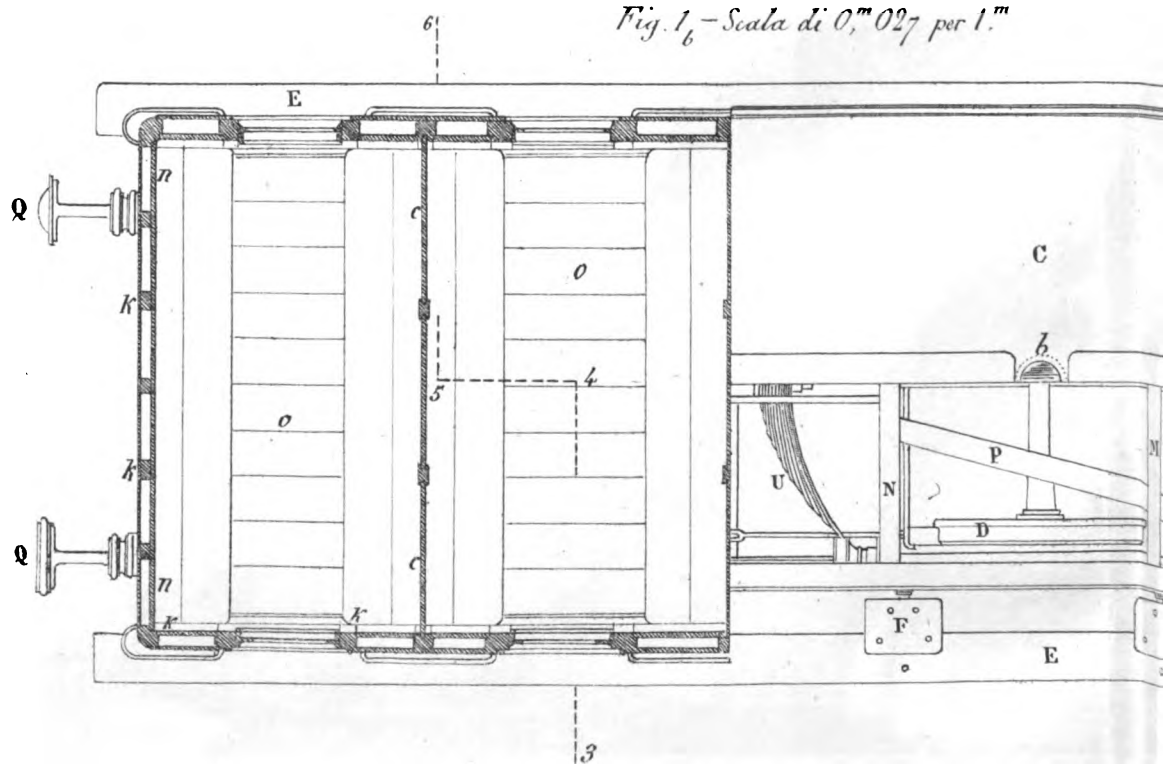

Fig. 1_b - Scala di 0.^m 027 per 1.^m



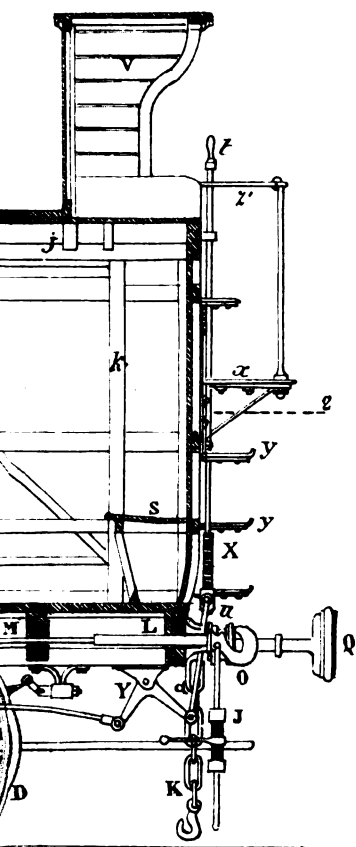

Fig. 1c
Scala di 0.^m 027 per 1.^m

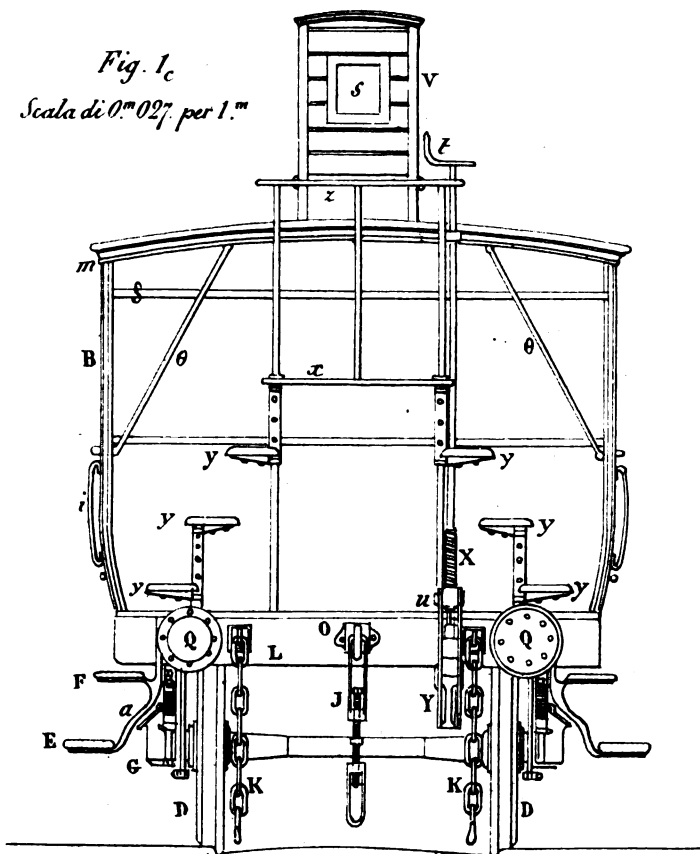
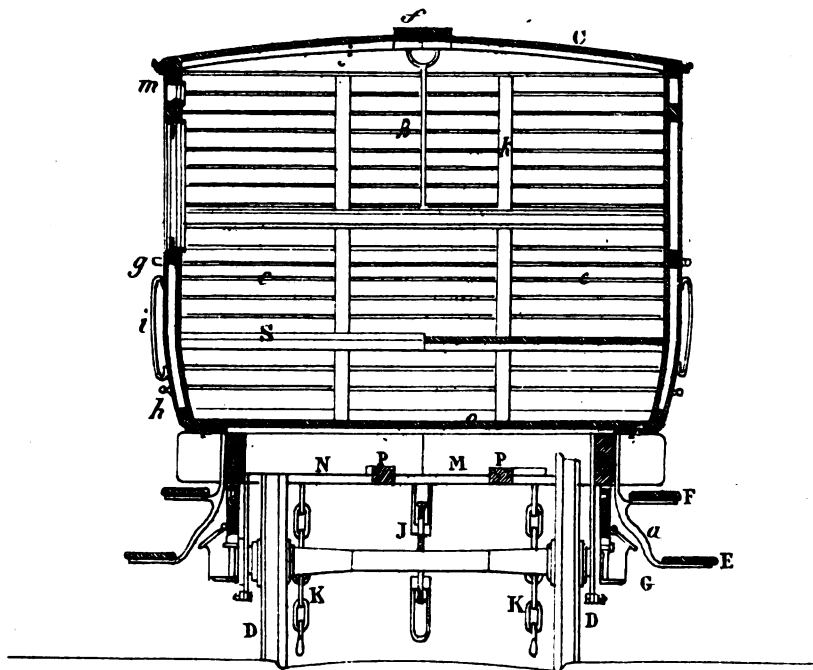
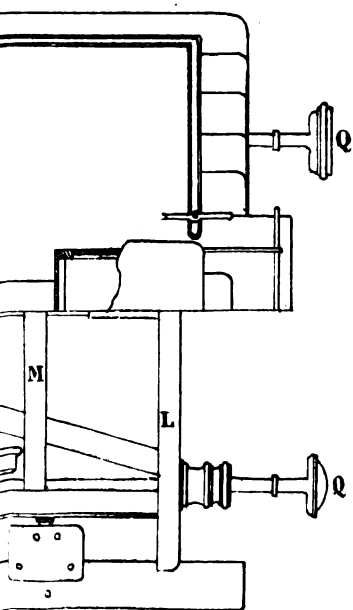

Fig. 1d - Scala di 0.^m 027 per 1.^m



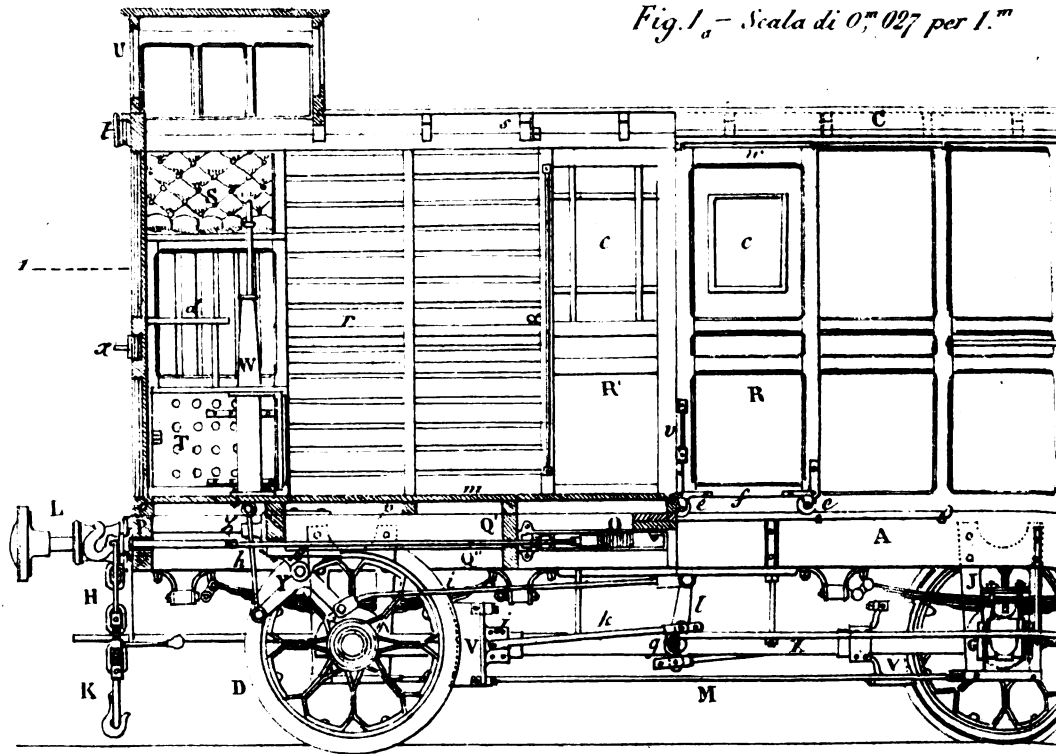

Fig. 1_a - Scala di 0.^m027 per 1.^m

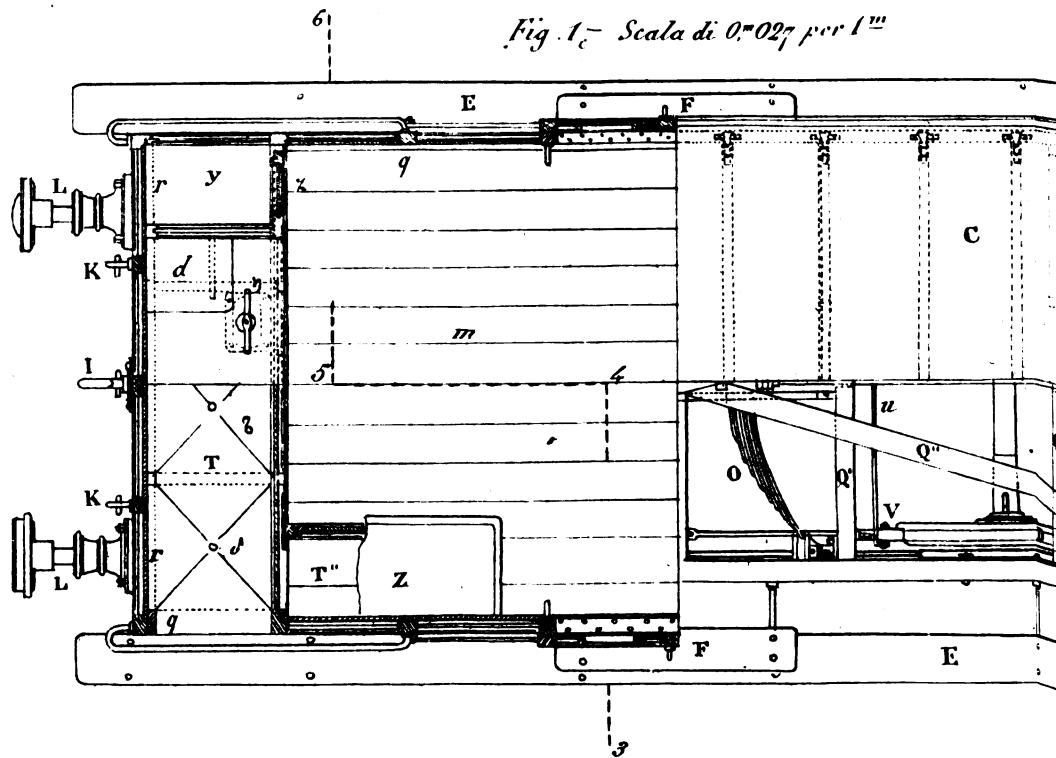

Fig. 1_c - Scala di 0.^m027 per 1.^m

Fig. 1_a - Scala di 0.^m 027 per 1

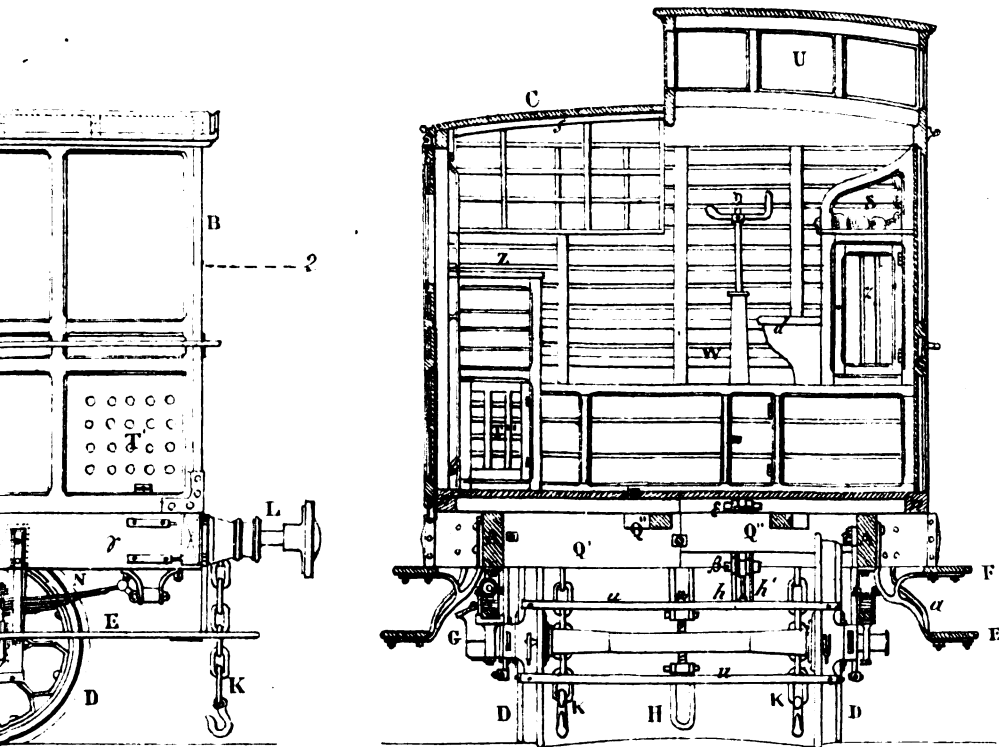
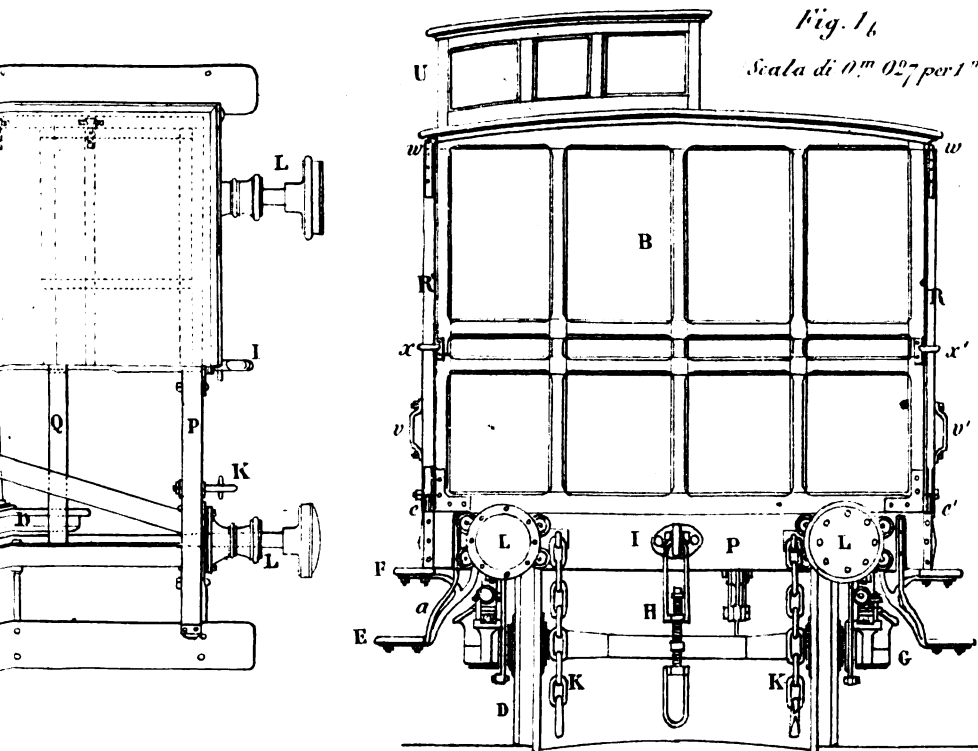
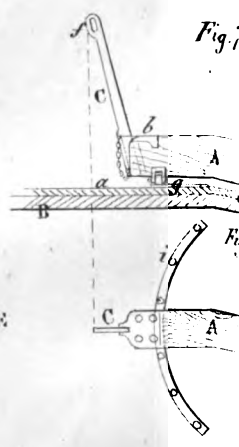
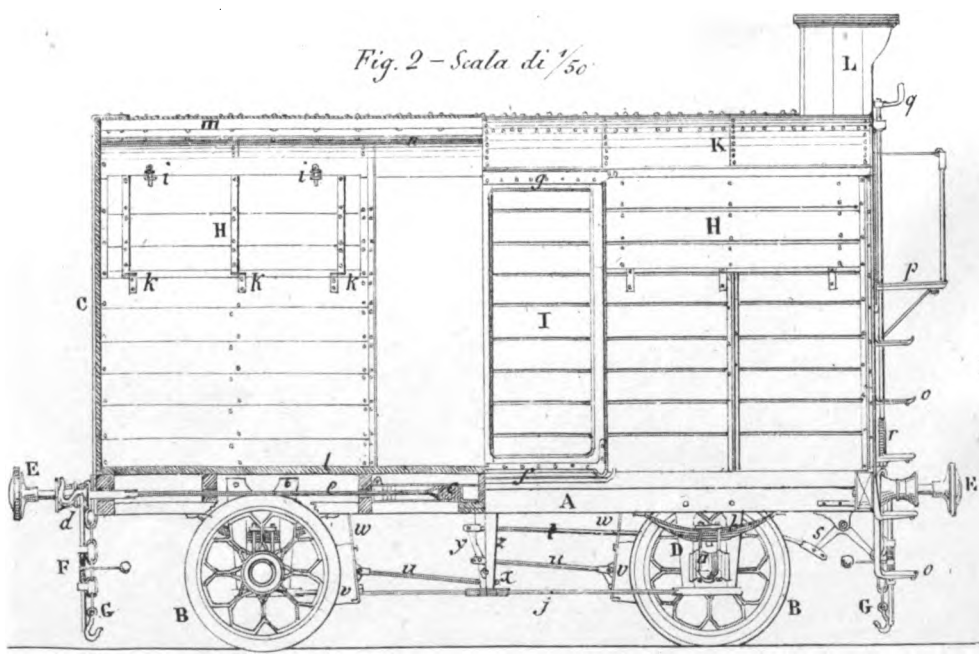
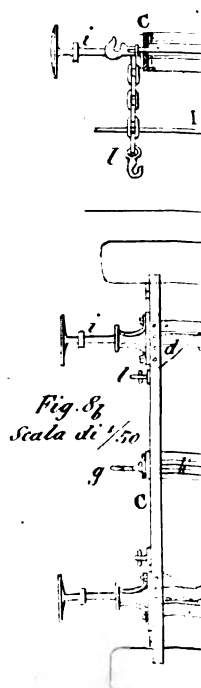
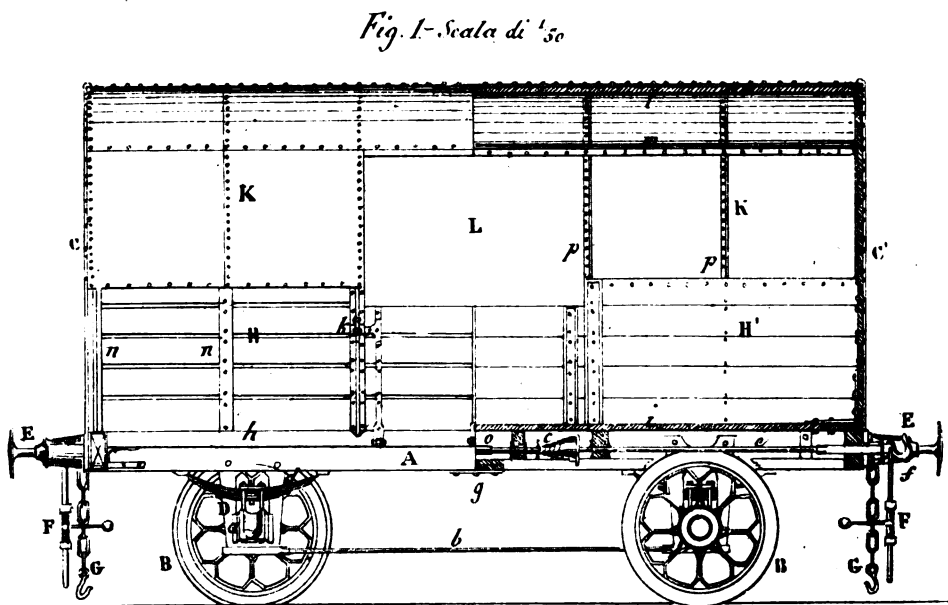
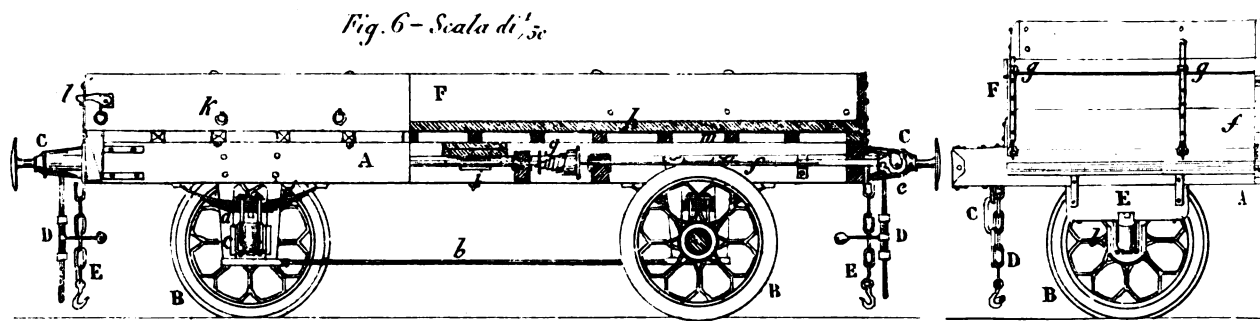

Fig. 1_b

Scala di 0.^m 027 per 1^m





Scala di $\frac{1}{50}$

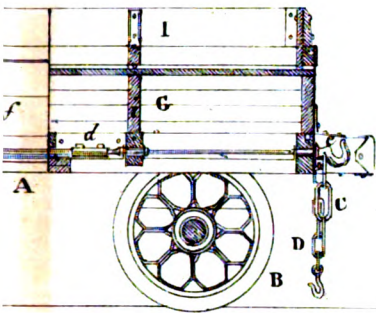

Fig. 5 - Scala di $\frac{1}{50}$

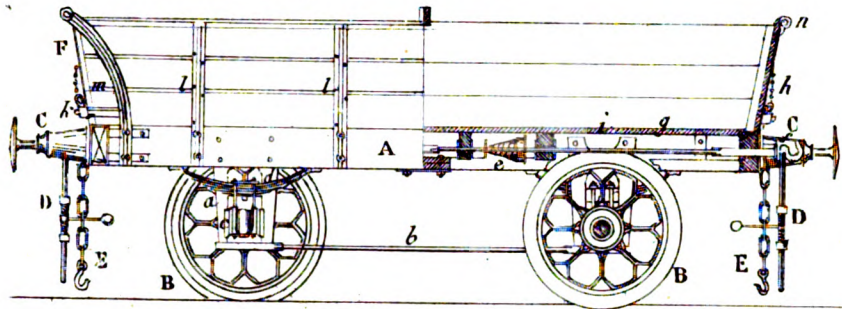

Fig. 8a - Scala di $\frac{1}{50}$

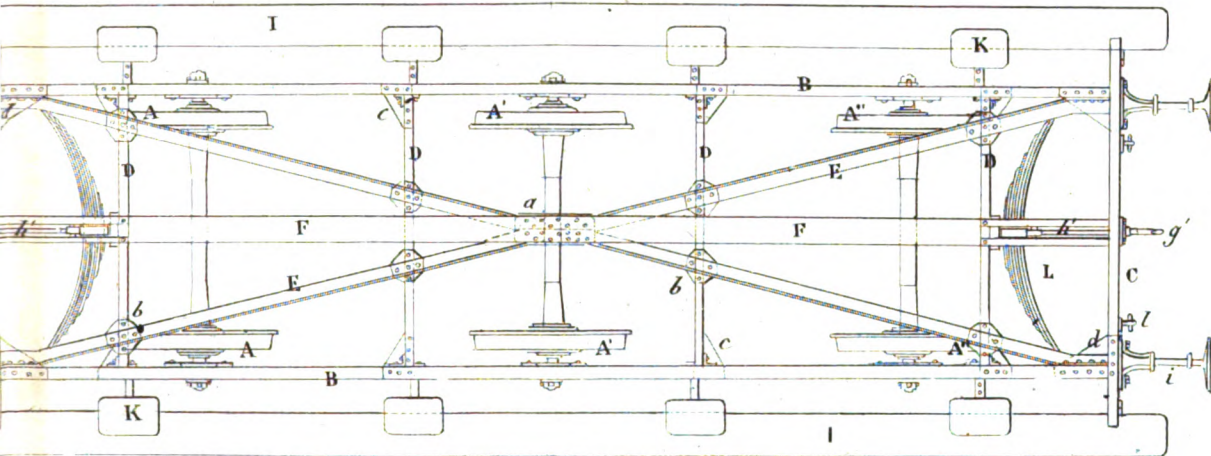
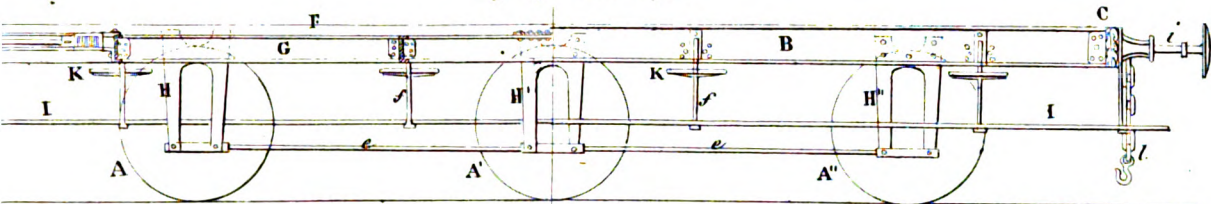

Fig. 3 - Scala di $\frac{1}{50}$

Fig. 7a - Scala $\frac{1}{50}$

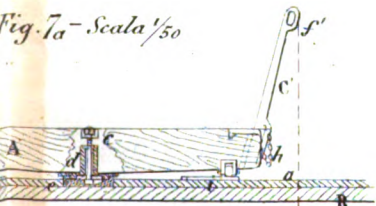
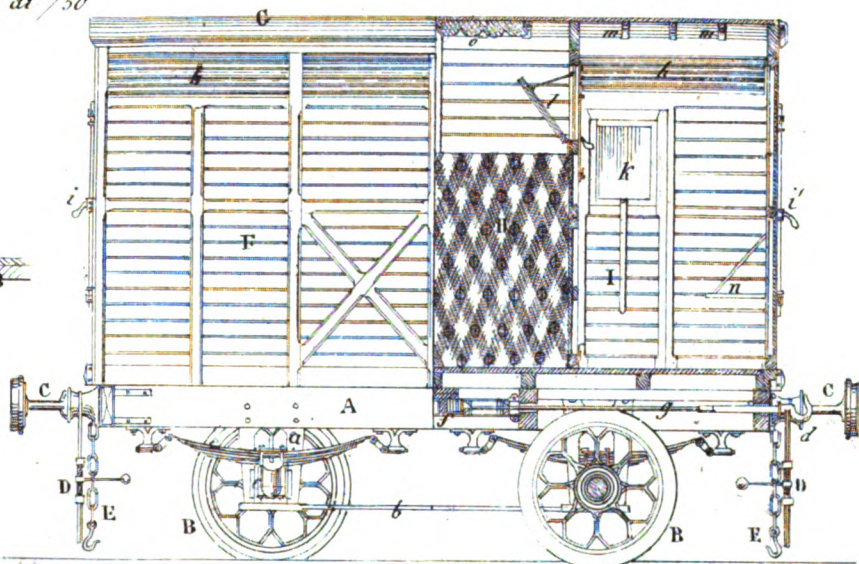
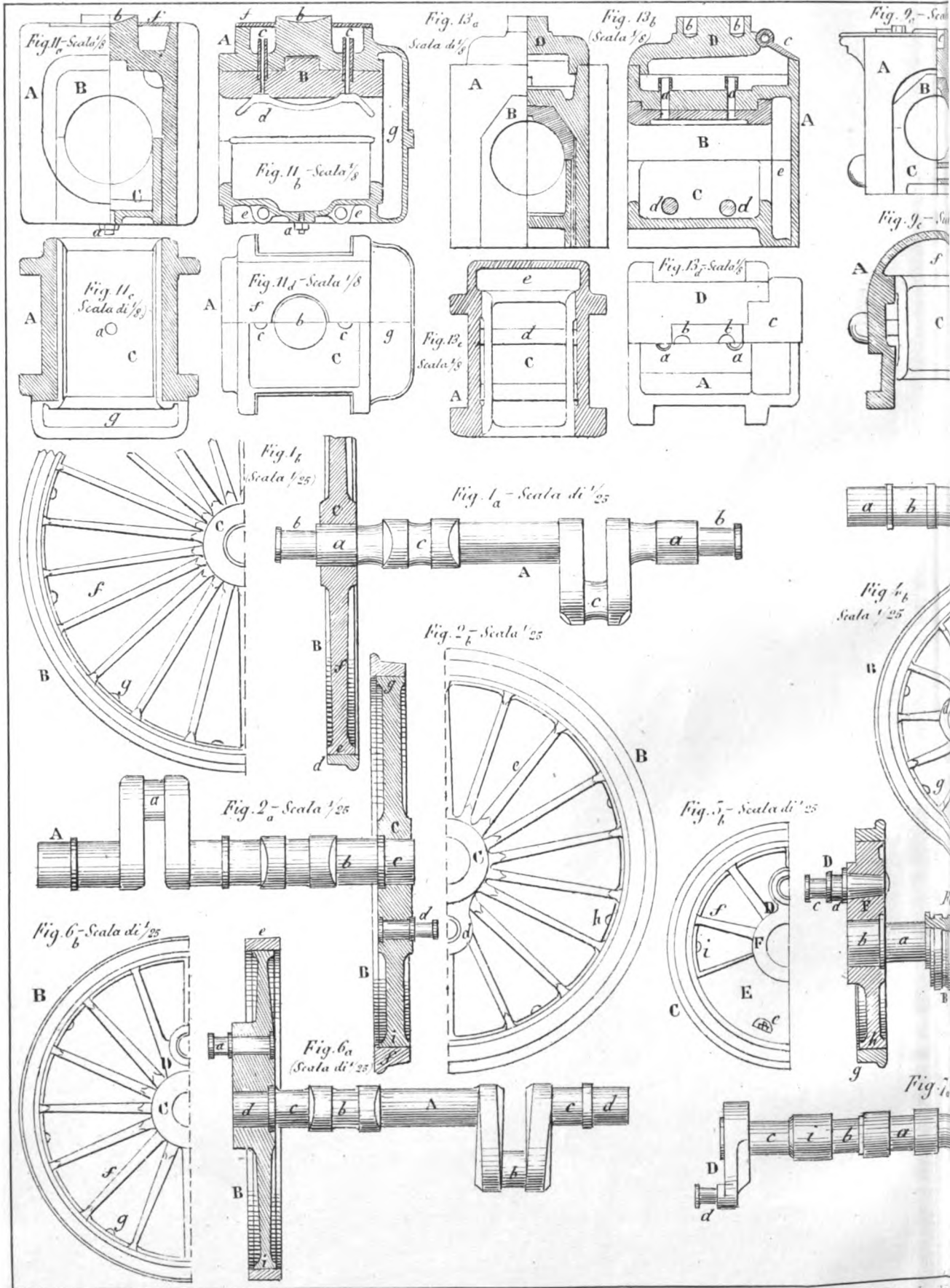
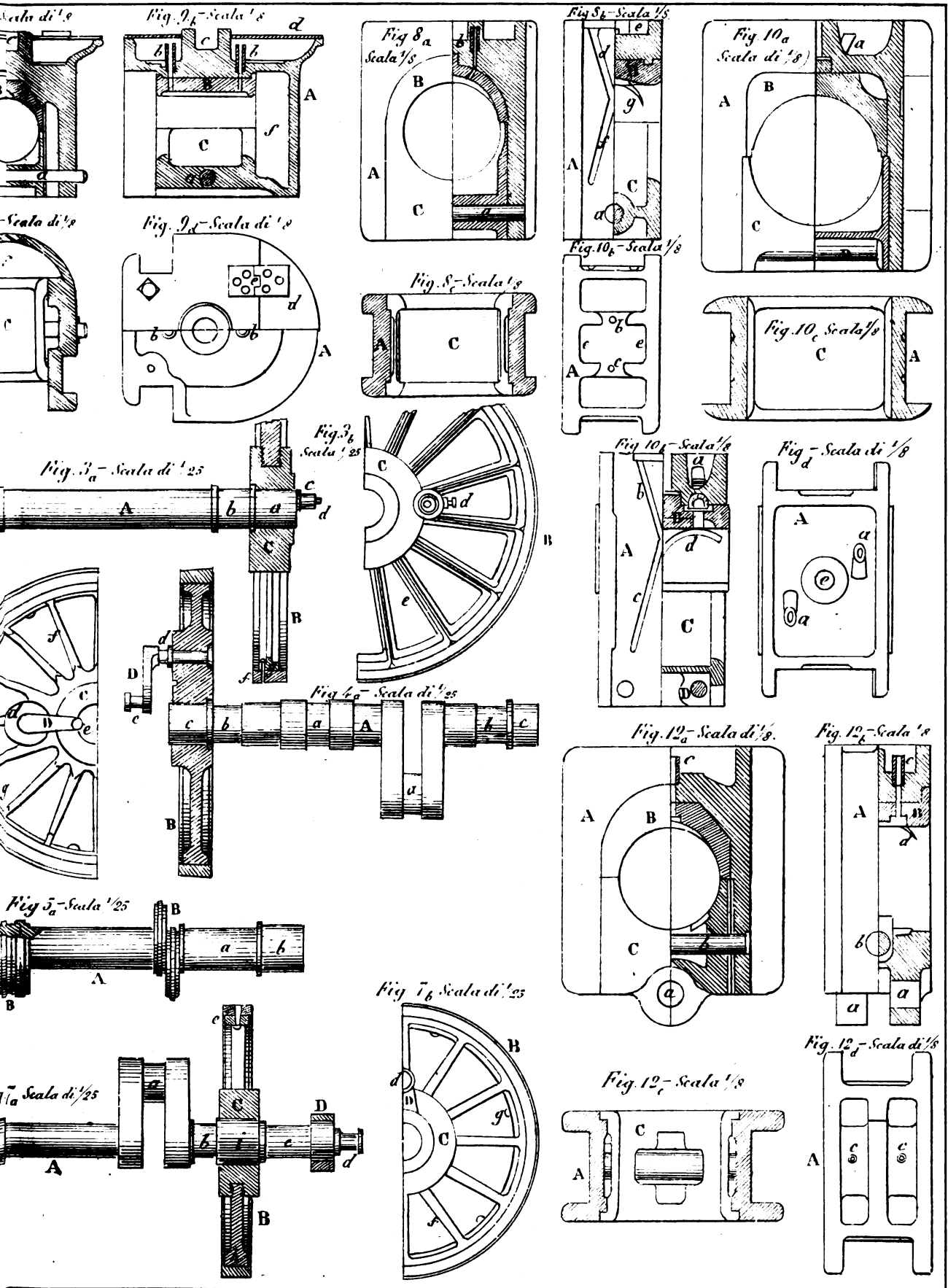

Fig. 7b - Scala $\frac{1}{50}$







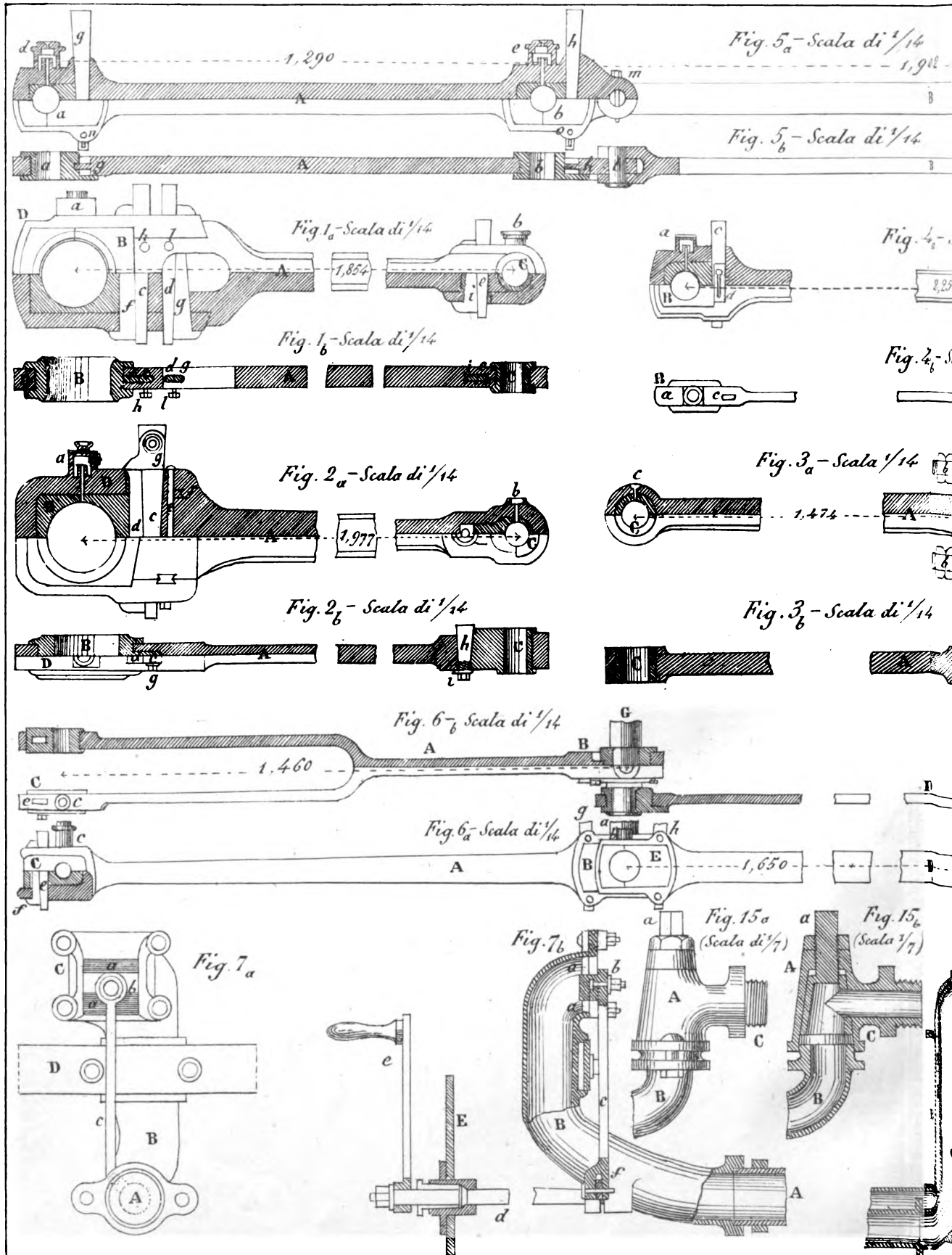

Fig. 1_a - Scala di 1/15

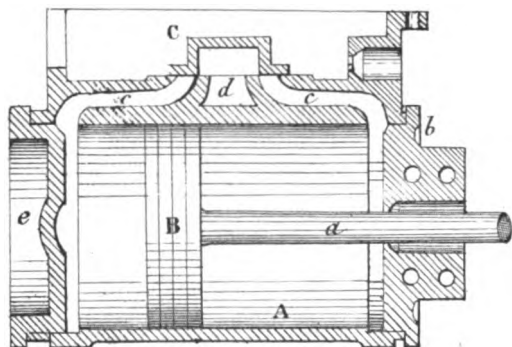

Fig. 1_b - Scala di 1/15

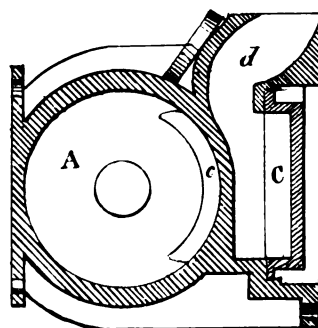

Fig. 1_c - Scala di 1/15

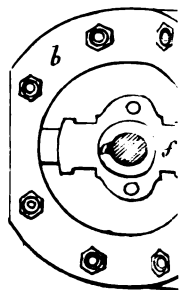

Fig. 2_a - Scala di 1/15

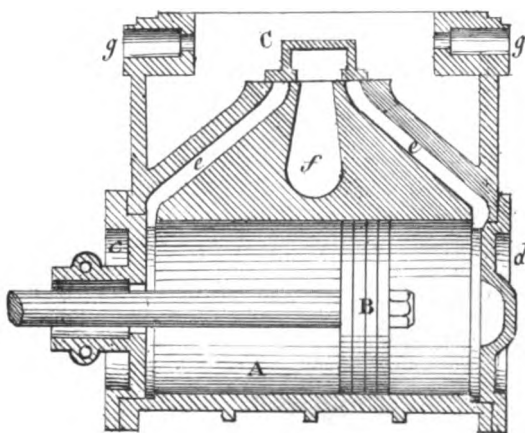

Fig. 2_b - Scala di 1/15

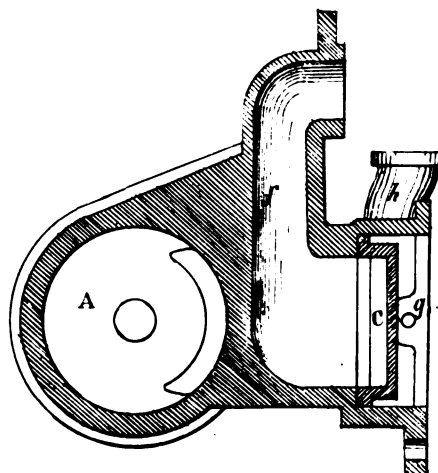

Fig. 2_c - Scala di 1/15

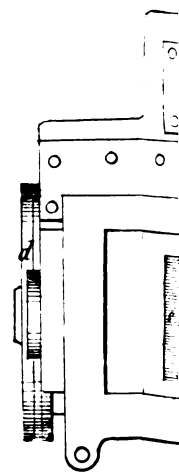

Fig. 3_a - Scala di 1/15

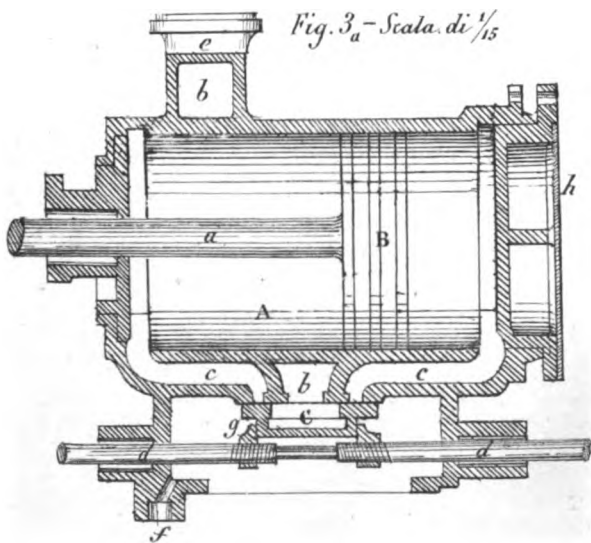

Fig. 3_b - Scala di 1/15

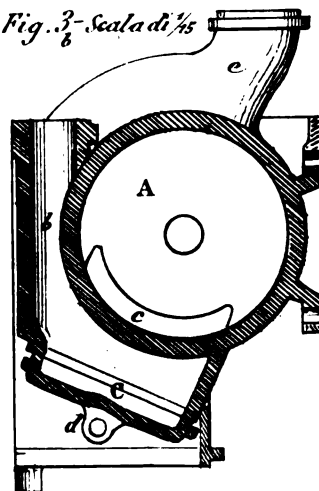

Fig. 3_c - Scala di 1/15



1-Scala di $\frac{1}{15}$

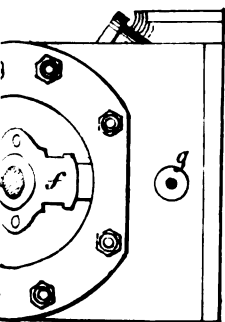
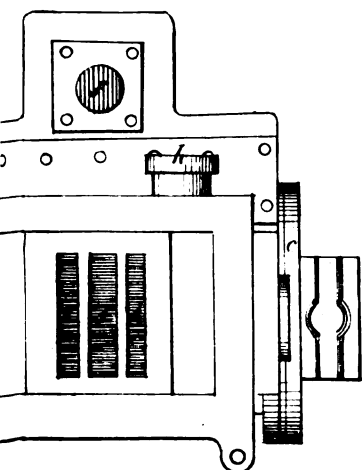

Fig. 2-Scala di $\frac{1}{15}$



3-Scala di $\frac{1}{15}$

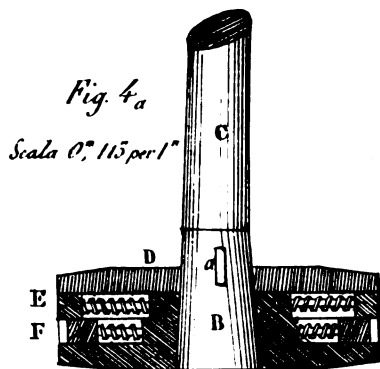
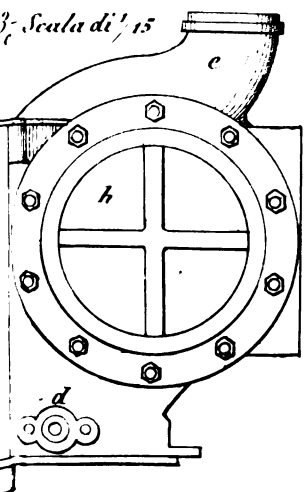

Fig. 4_a
Scala 0^m 115 per 1^m

Fig. 4_b - Scala 0^m 115 per 1^m

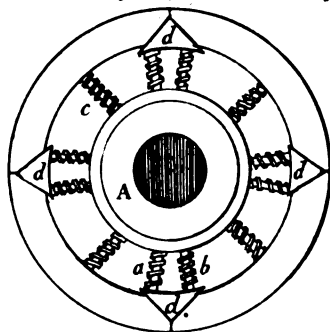

Fig. 6_a - Scala $\frac{1}{10}$

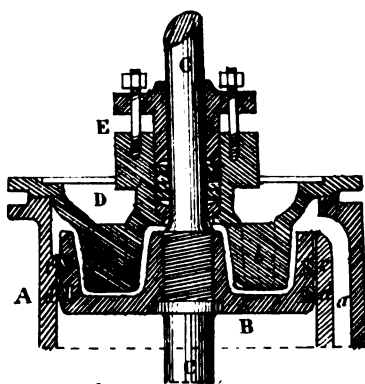

Fig. 6_b - Scala $\frac{1}{10}$

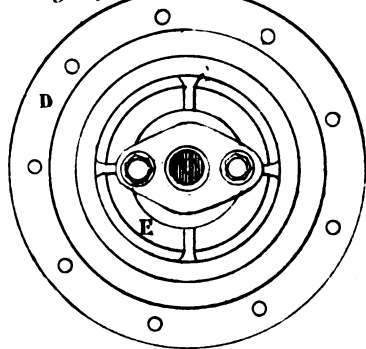

Fig. 5_a - Scala 0^m 165 per 1^m

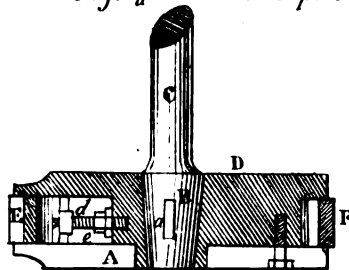

Fig. 5_b - Scala 0^m 165 per 1^m

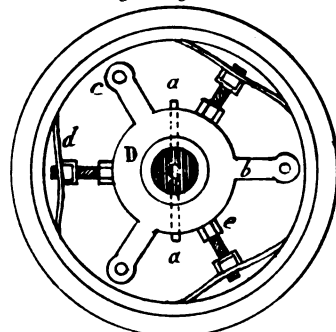

Fig. 7_a - Scala 0^m 165 per 1^m

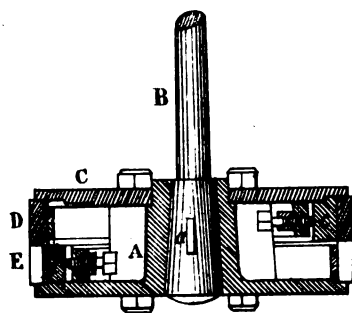
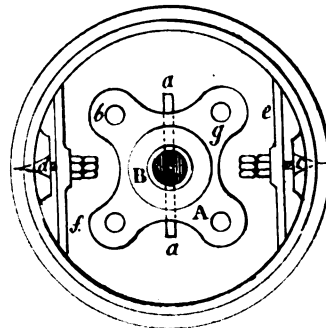

Fig. 7_b - Scala 0^m 165 per 1^m



Sezione longitudinale

Scala di 1/25

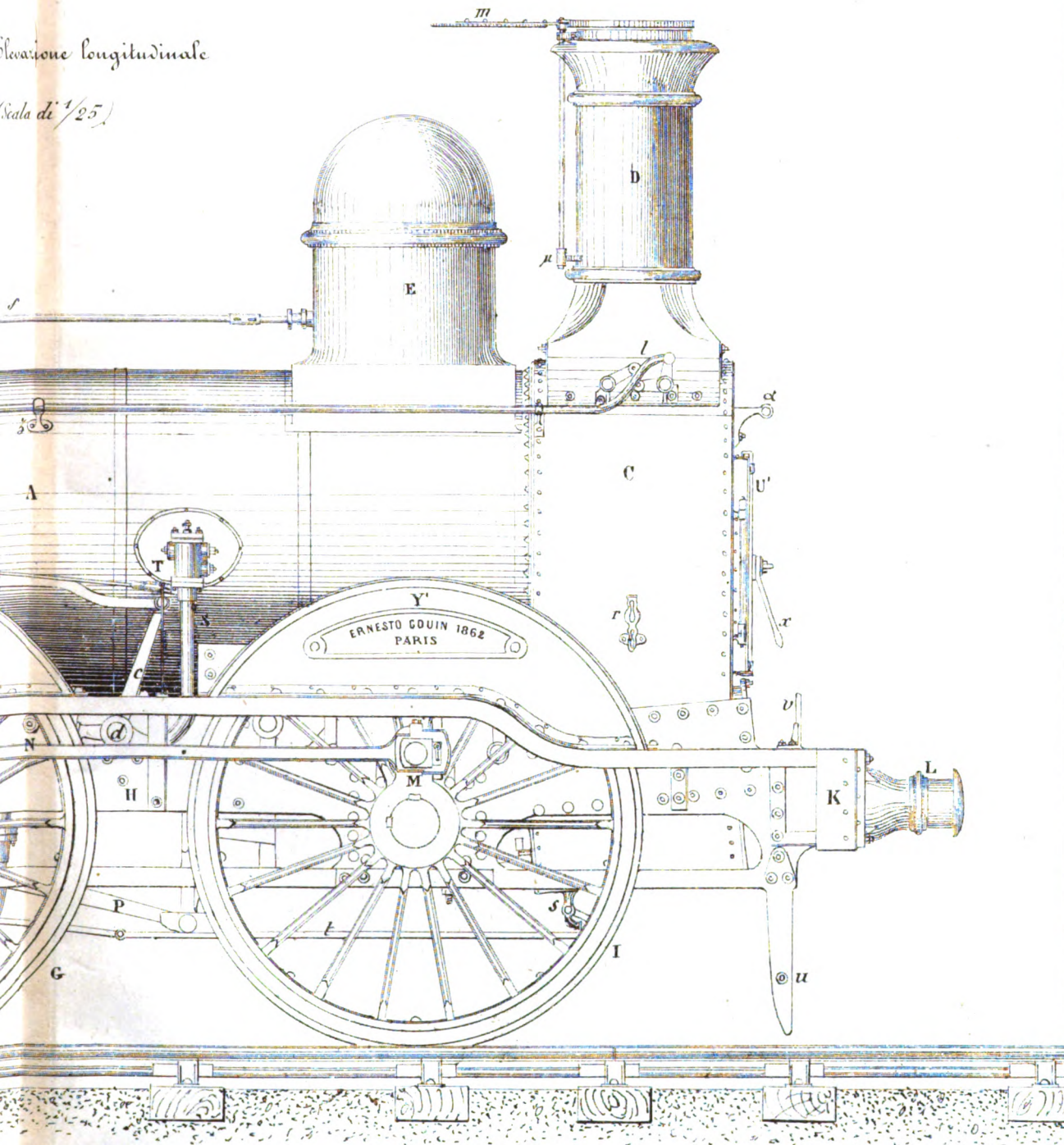
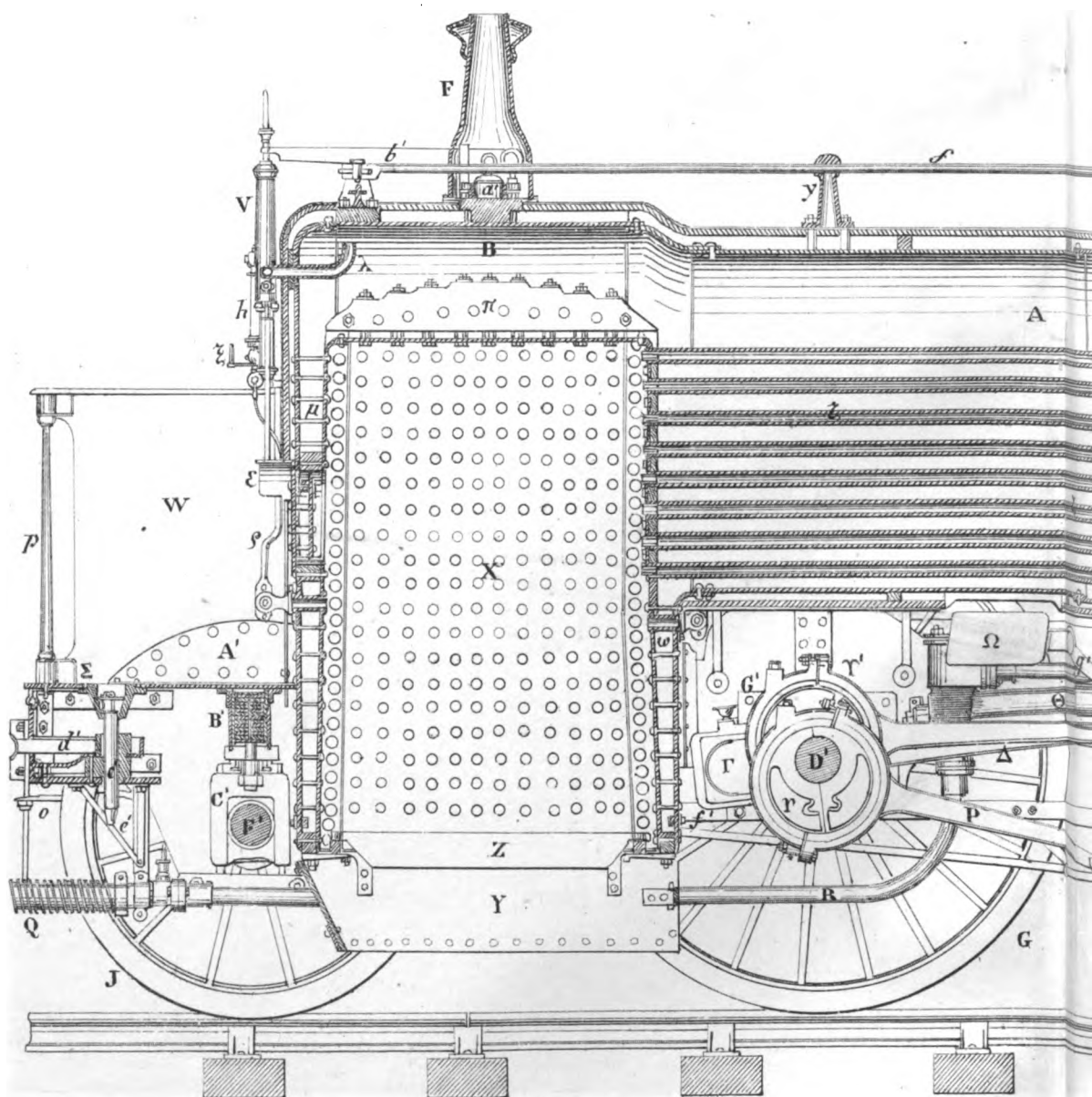

Fig. 1. - Sezione longitudinale
(Scala di 1/25)



Giulio Franco dis.

Lit P Briola Via S Franceso...

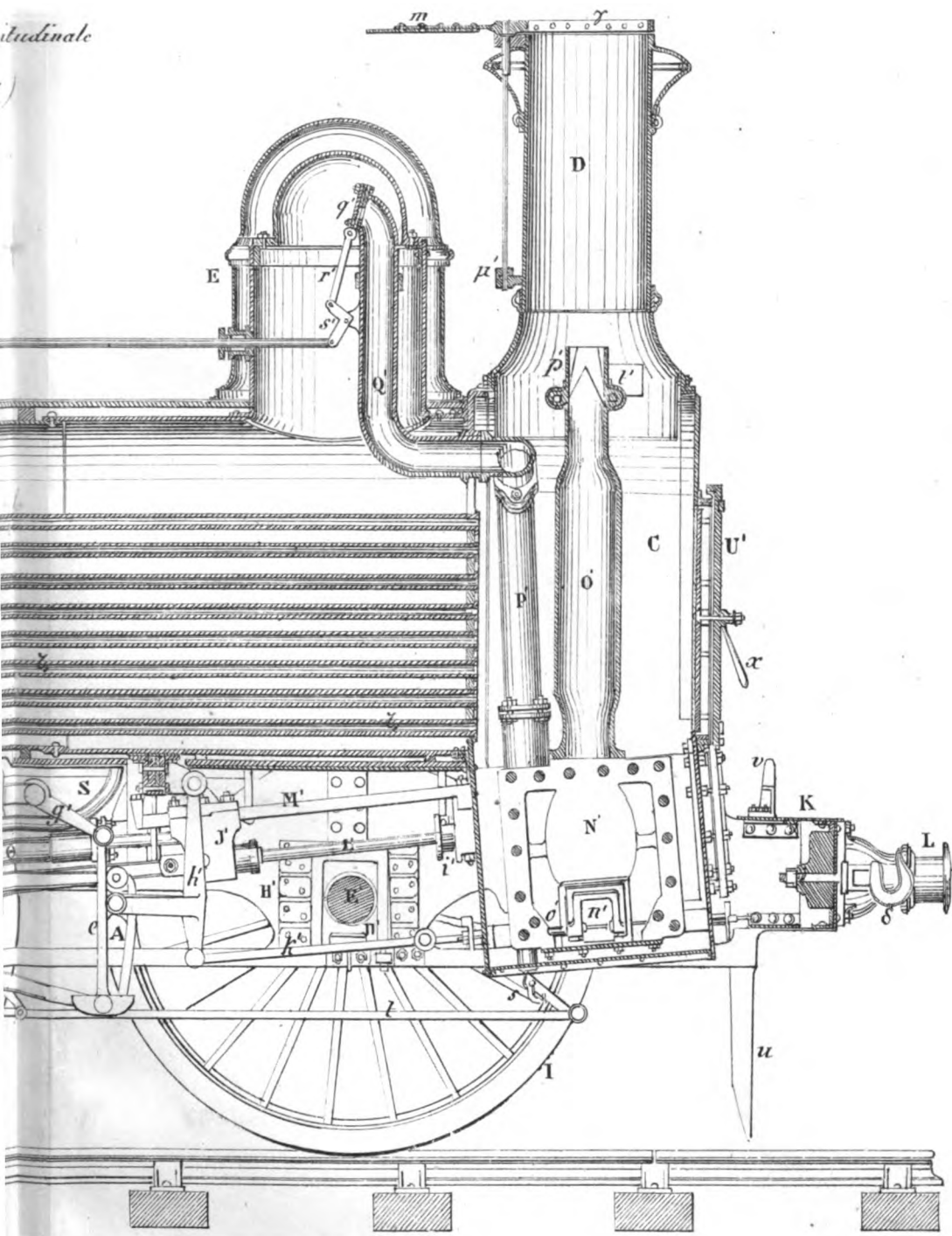

Fig. 1. - Elevazione posteriore e sezione trasversale sulla cassa del focolare (Scala 1/25)

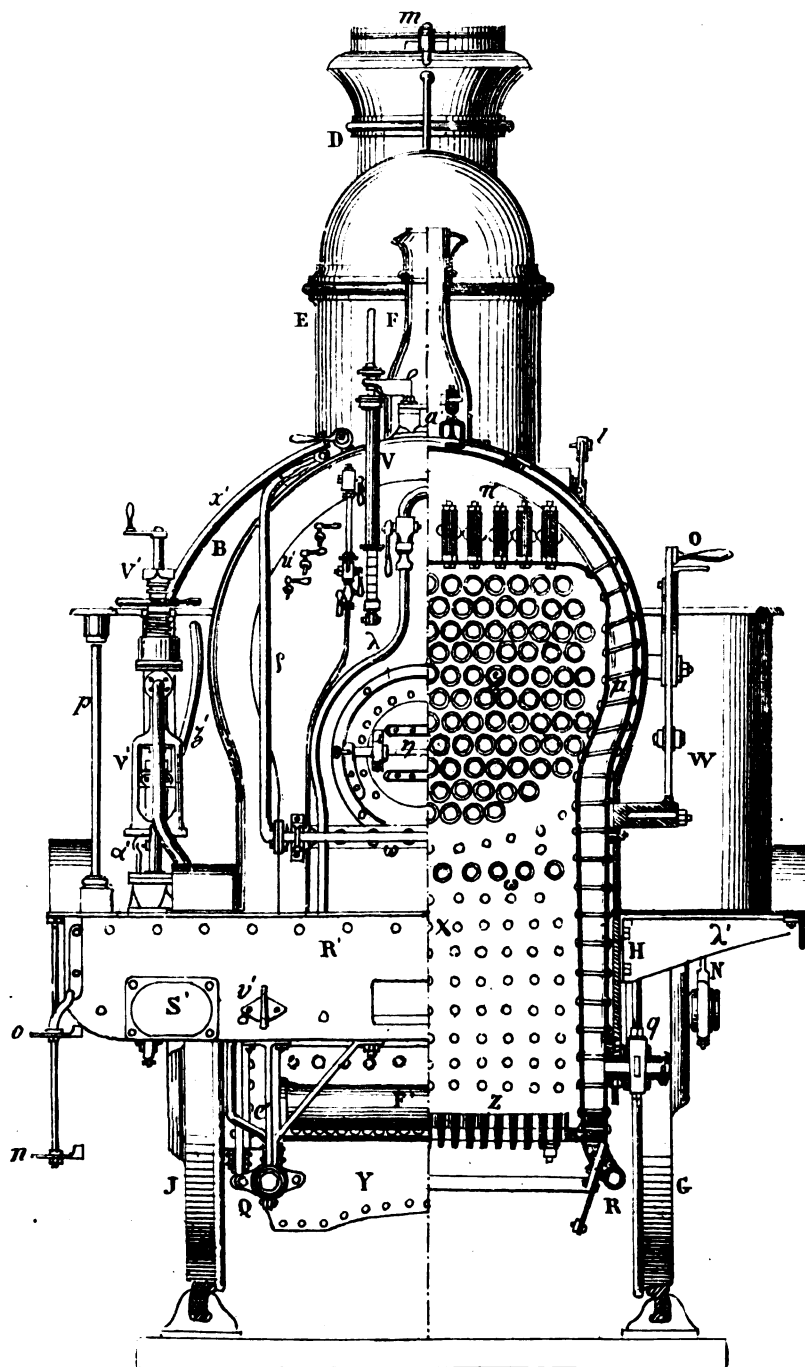
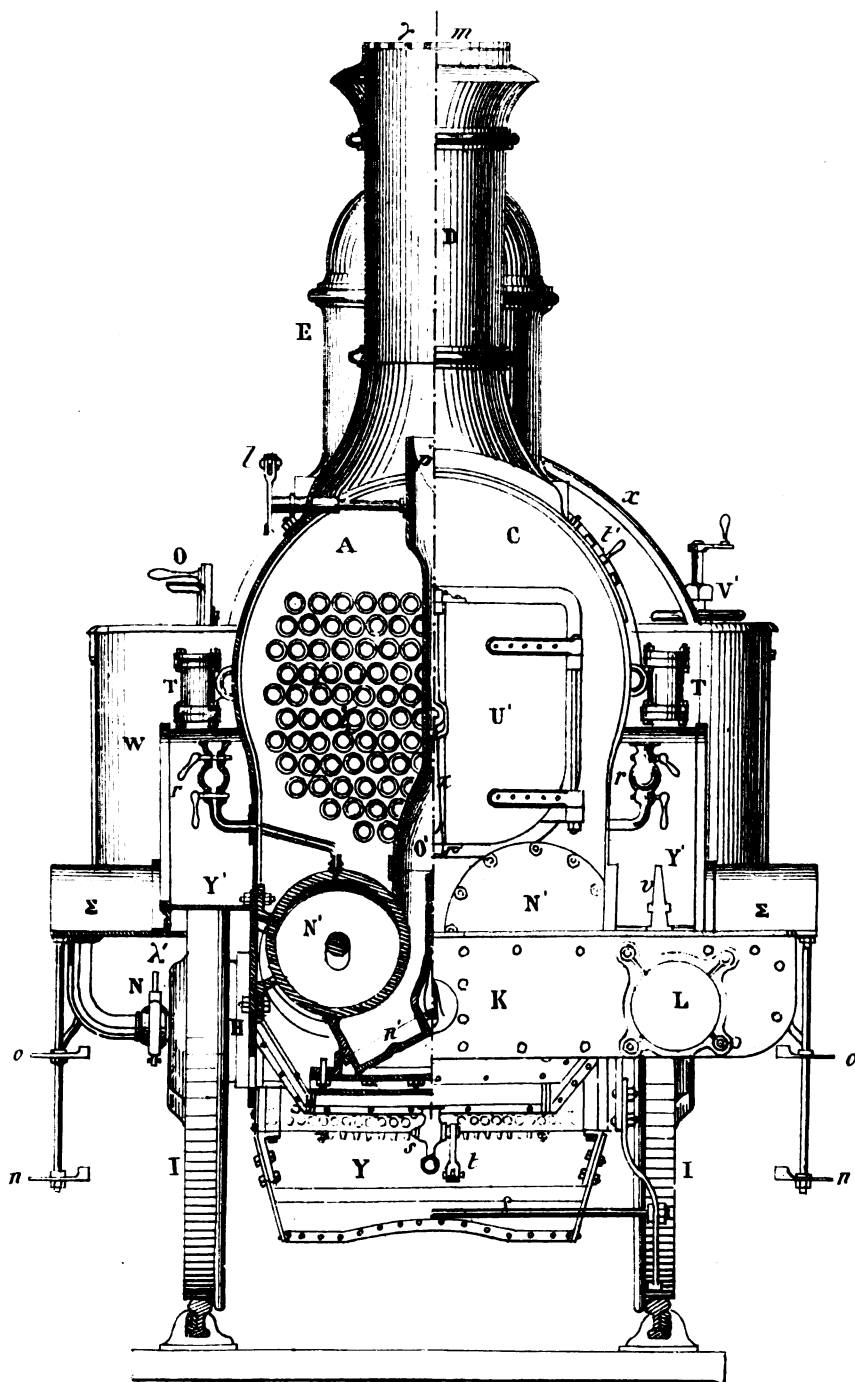

Fig. 1 - Elevazione anteriore e sezione trasversale sulla cassa del fumo (Scala 1/25)



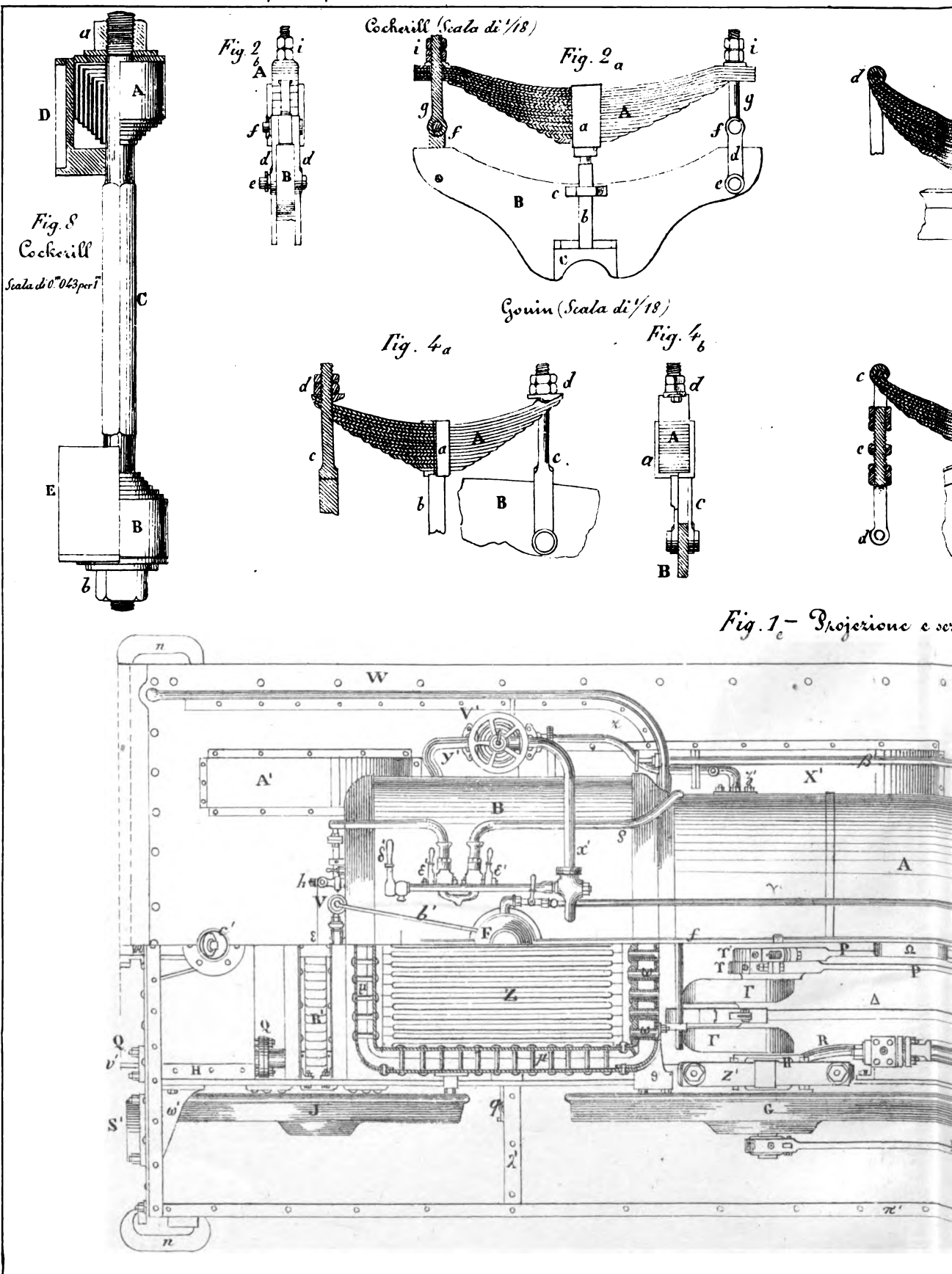

Fig. 1 - Proiezione e sezione

Sharp e Roberts (Scala di 1/18) Fig. 3

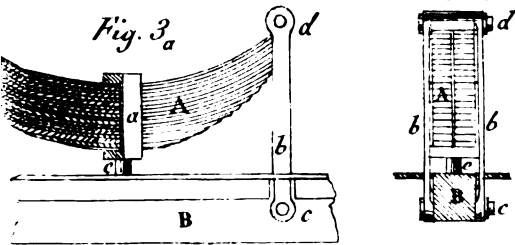
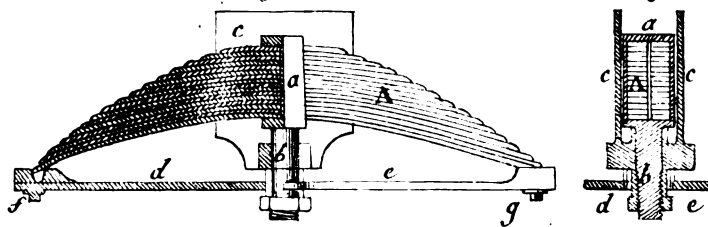

Fig. 7a Cjovin (Scala 1/18) Fig. 7b



Sharp e Roberts (Scala di 1/18)

Fig. 5a

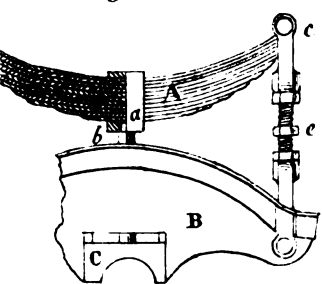
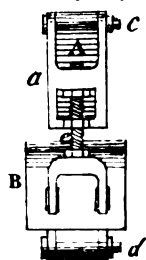

Fig. 5b



Stephenson (Scala 1/18)

Fig. 6a

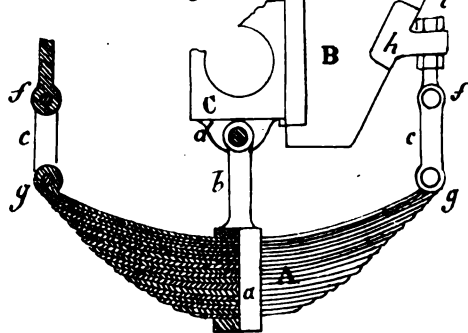
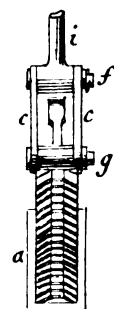

Fig. 6b



sezione orizzontali (Scala di 1/25)

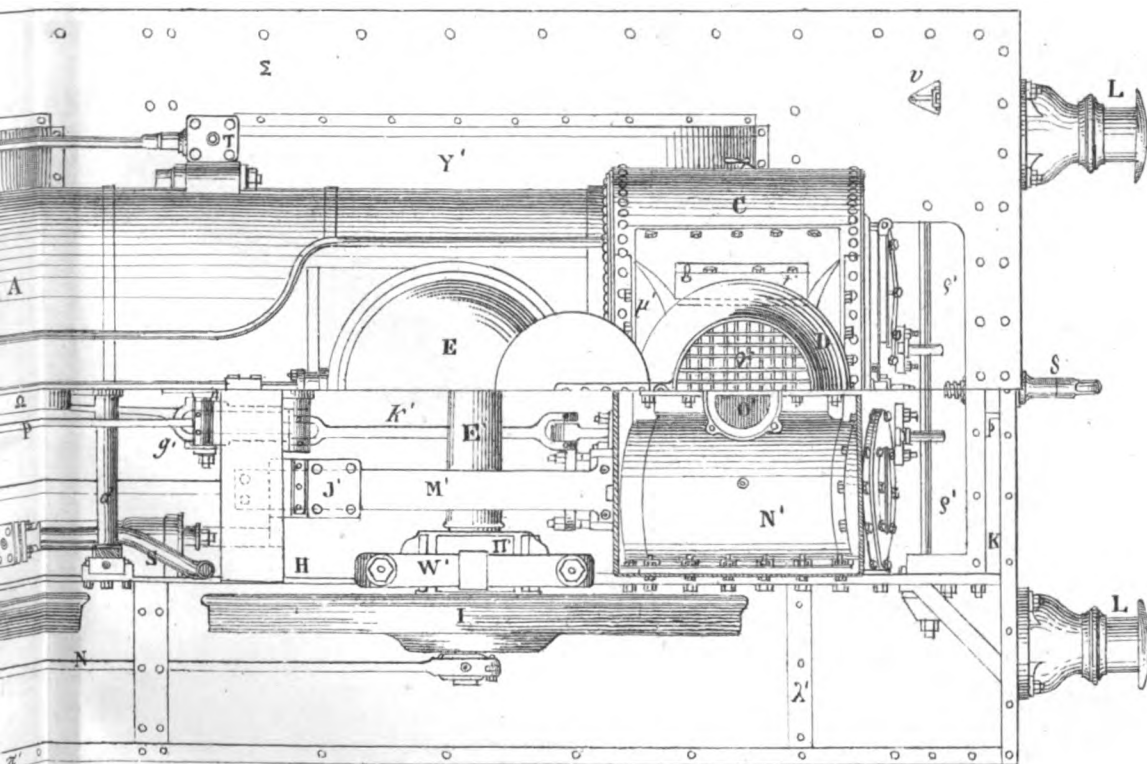

Fig. 1_a - Sezione longitudinale (Scala di 1/33)

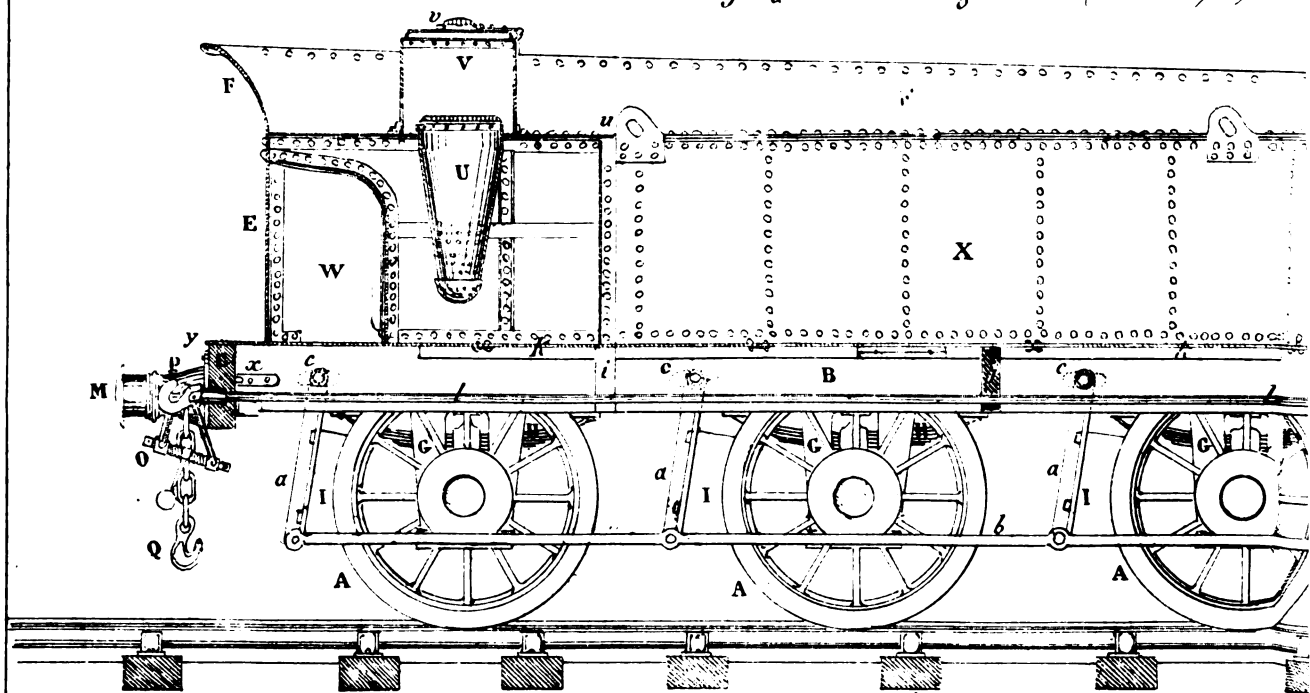
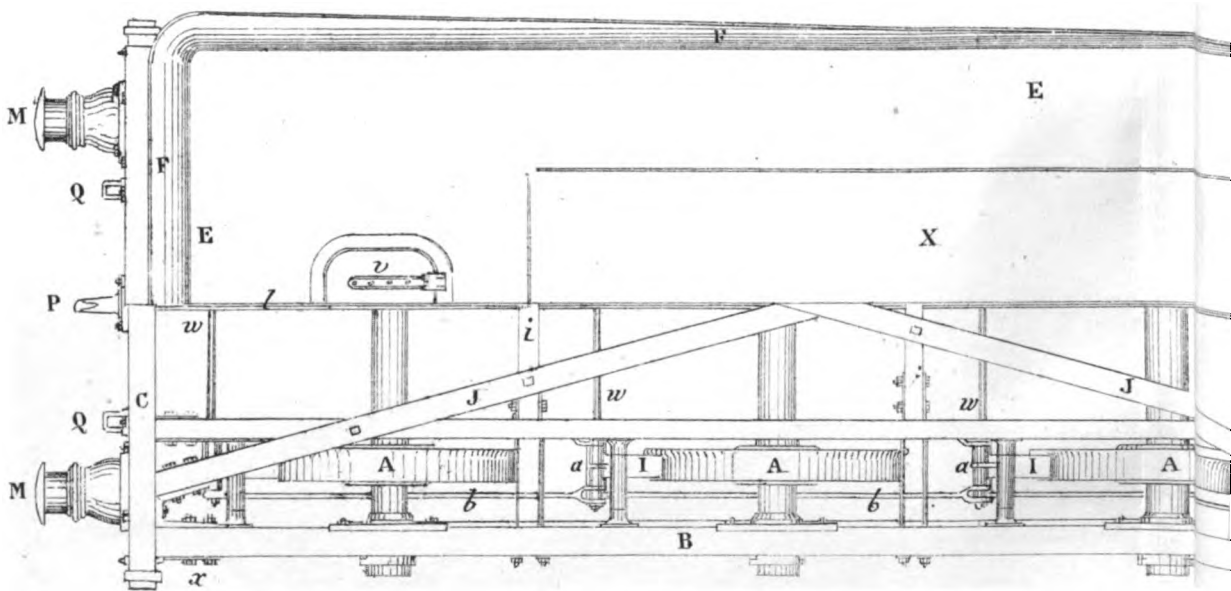

Fig. 1_b - Proiezione e Sezione orizzontali (Scala di 1/3)



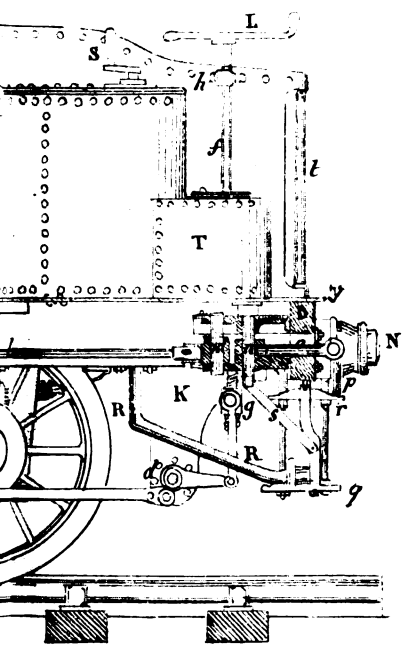

Fig. 2 Gouin
(Scala di $\frac{1}{9}$)

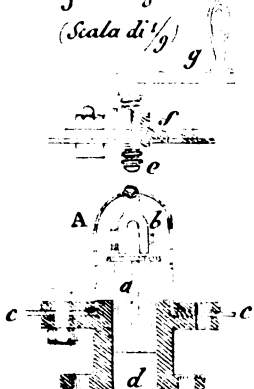

Fig. 3 Stephenson
(Scala di $\frac{1}{9}$)

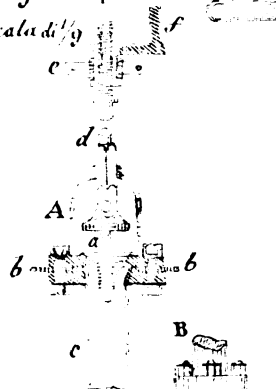
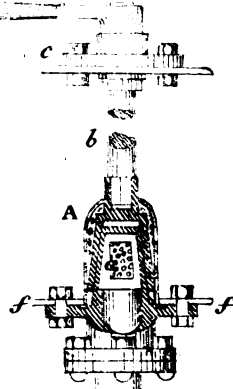
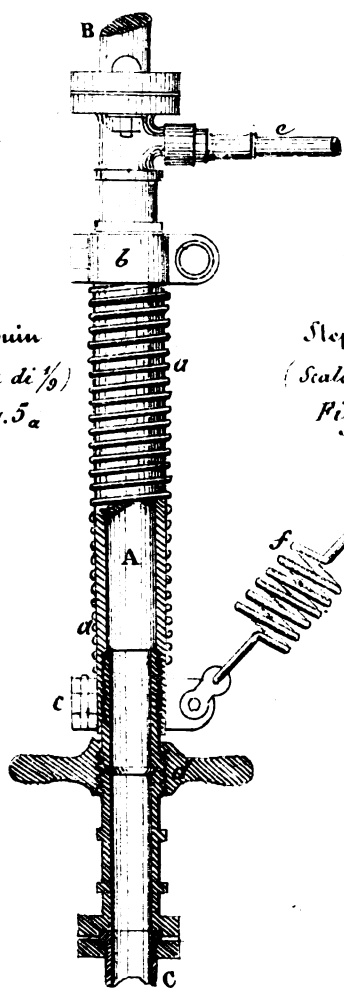

Fig. 4-Cocherill (Scala di $\frac{1}{9}$)



Gouin
(Scala di $\frac{1}{9}$)
Fig. 5_a



Stephenson
(Scala di $\frac{1}{9}$)
Fig. 6

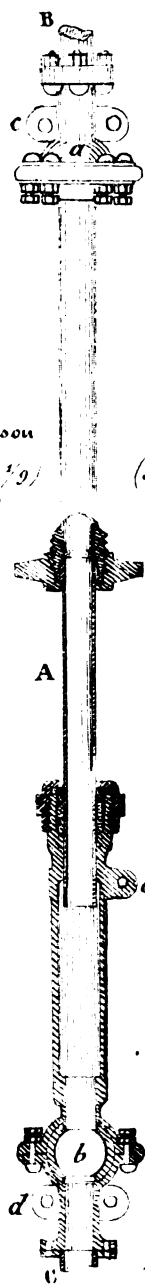

Cocherill
(Scala di $\frac{1}{9}$)
Fig. 7_a

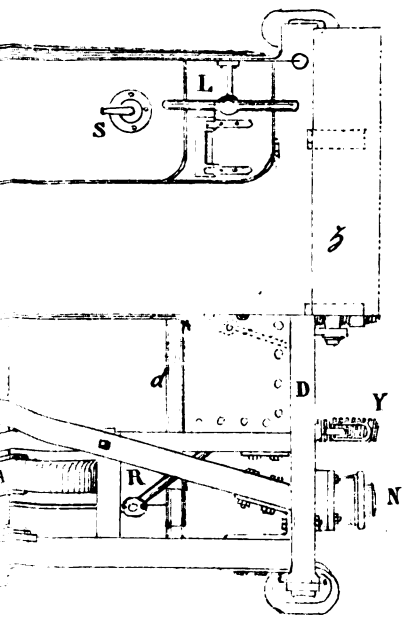
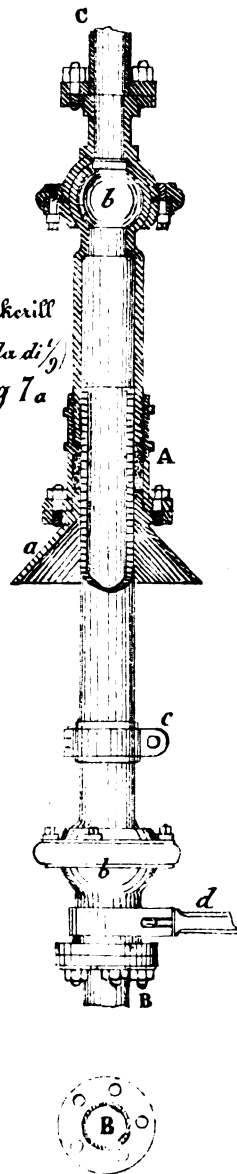
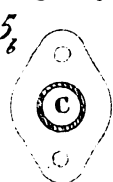

Fig. 5_b



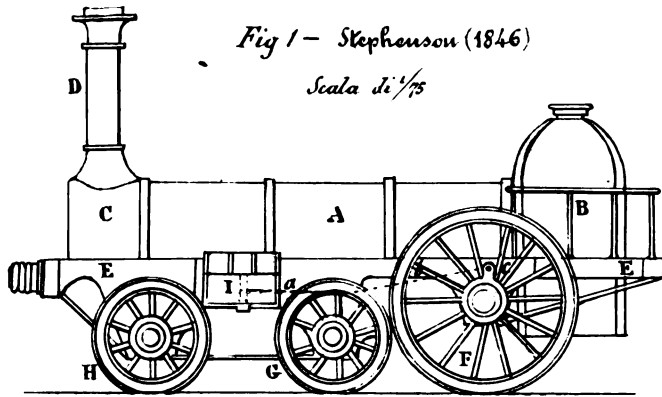

Fig. 1 - Stephenson (1846)
Scala di $\frac{1}{75}$

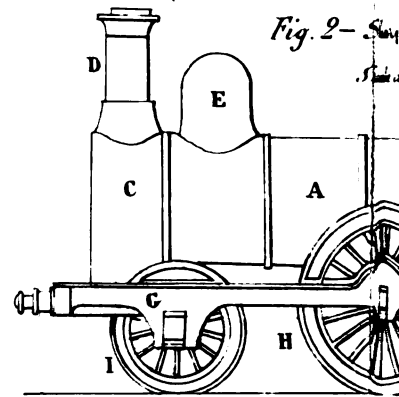

Fig. 2 - Stephenson (1846)
Scala di $\frac{1}{75}$

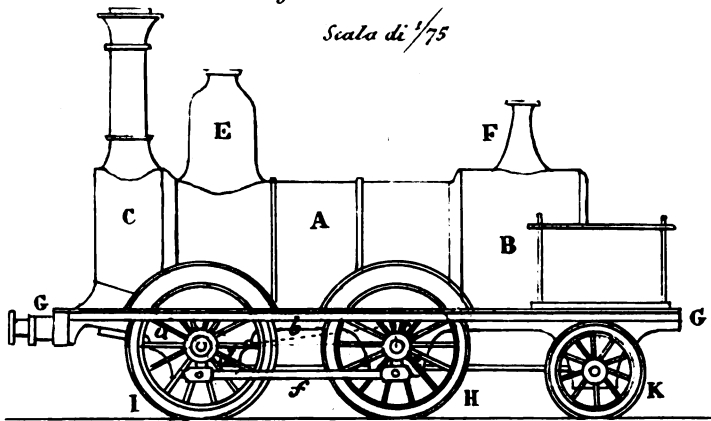

Fig. 4 - Ansaldo (1855)
Scala di $\frac{1}{75}$

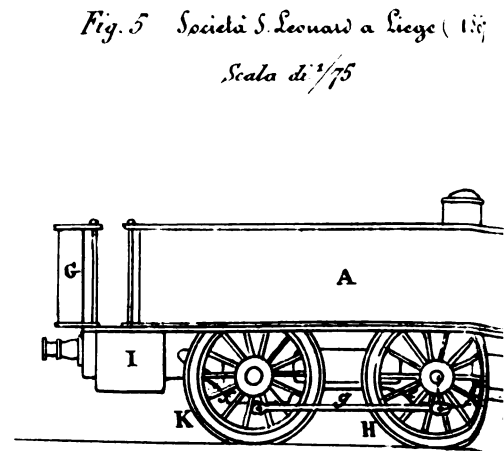

Fig. 5 - Società S. Leonard a Liege (1858)
Scala di $\frac{1}{75}$

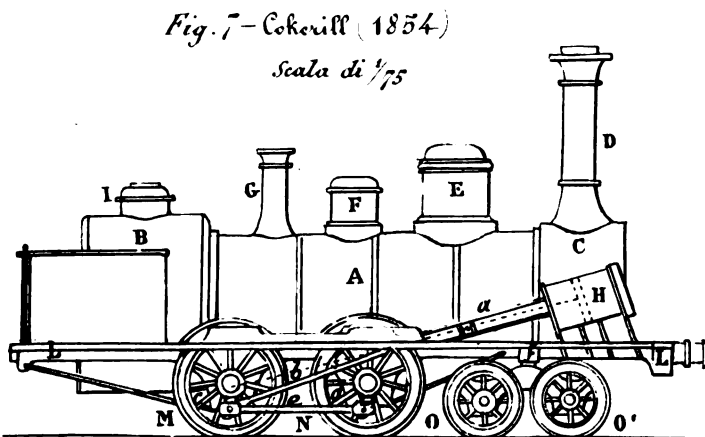

Fig. 7 - Cokerill (1854)
Scala di $\frac{1}{75}$

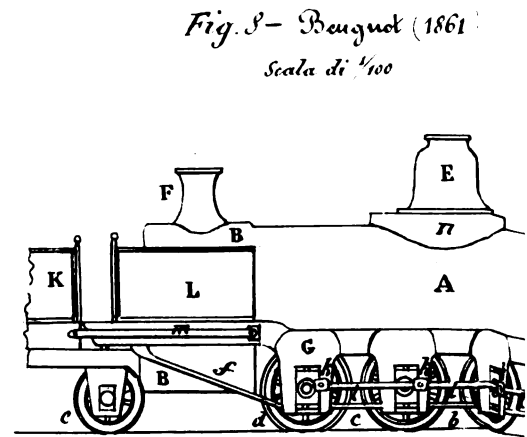

Fig. 8 - Bagnot (1861)
Scala di $\frac{1}{100}$

Fig. 2- Sharp e Roberts (1853)

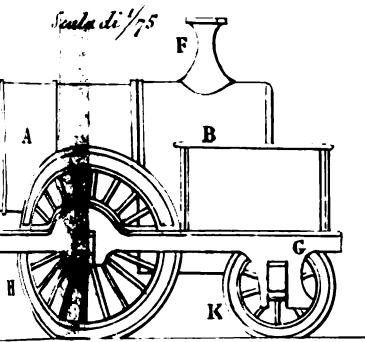

Fig. 3- Derosne e Cail (sistema Clapton = 1849)

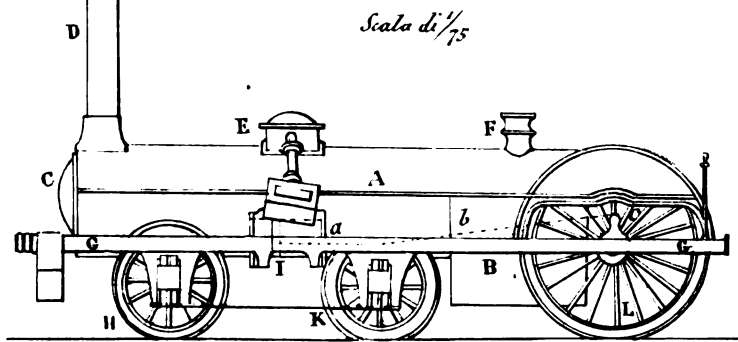

Fig. 4- 1867

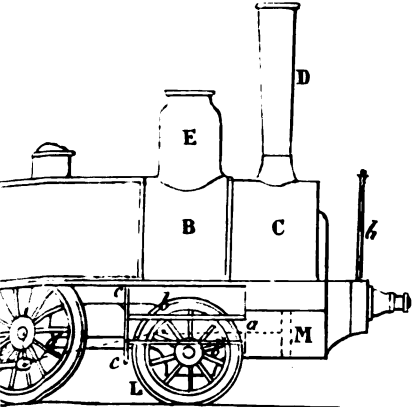

Fig. 6- Stephenson (1851)

Scala di $\frac{1}{75}$.

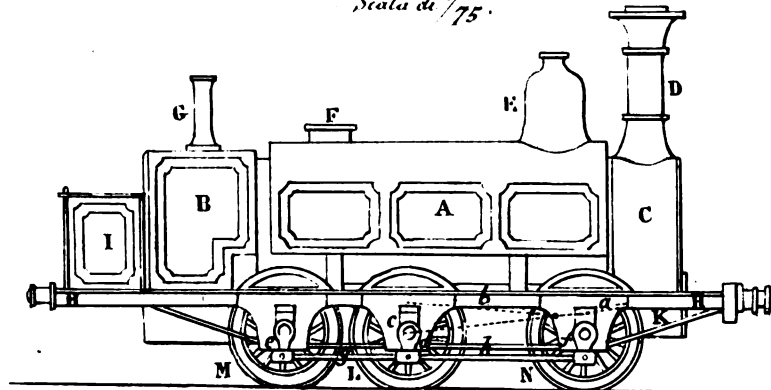

Fig. 8

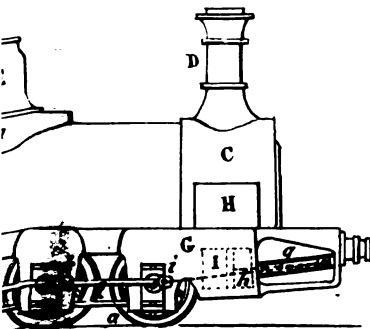
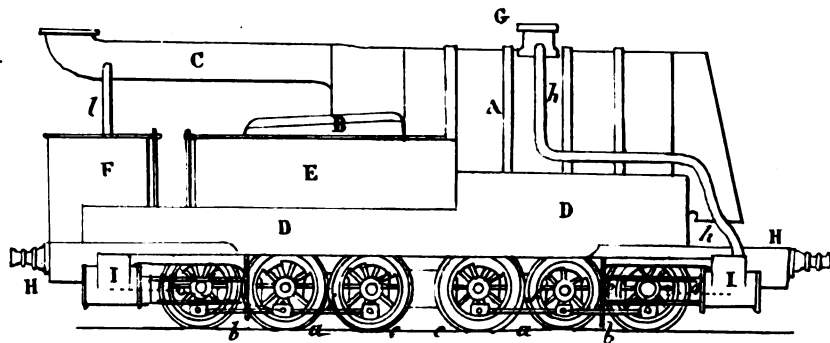
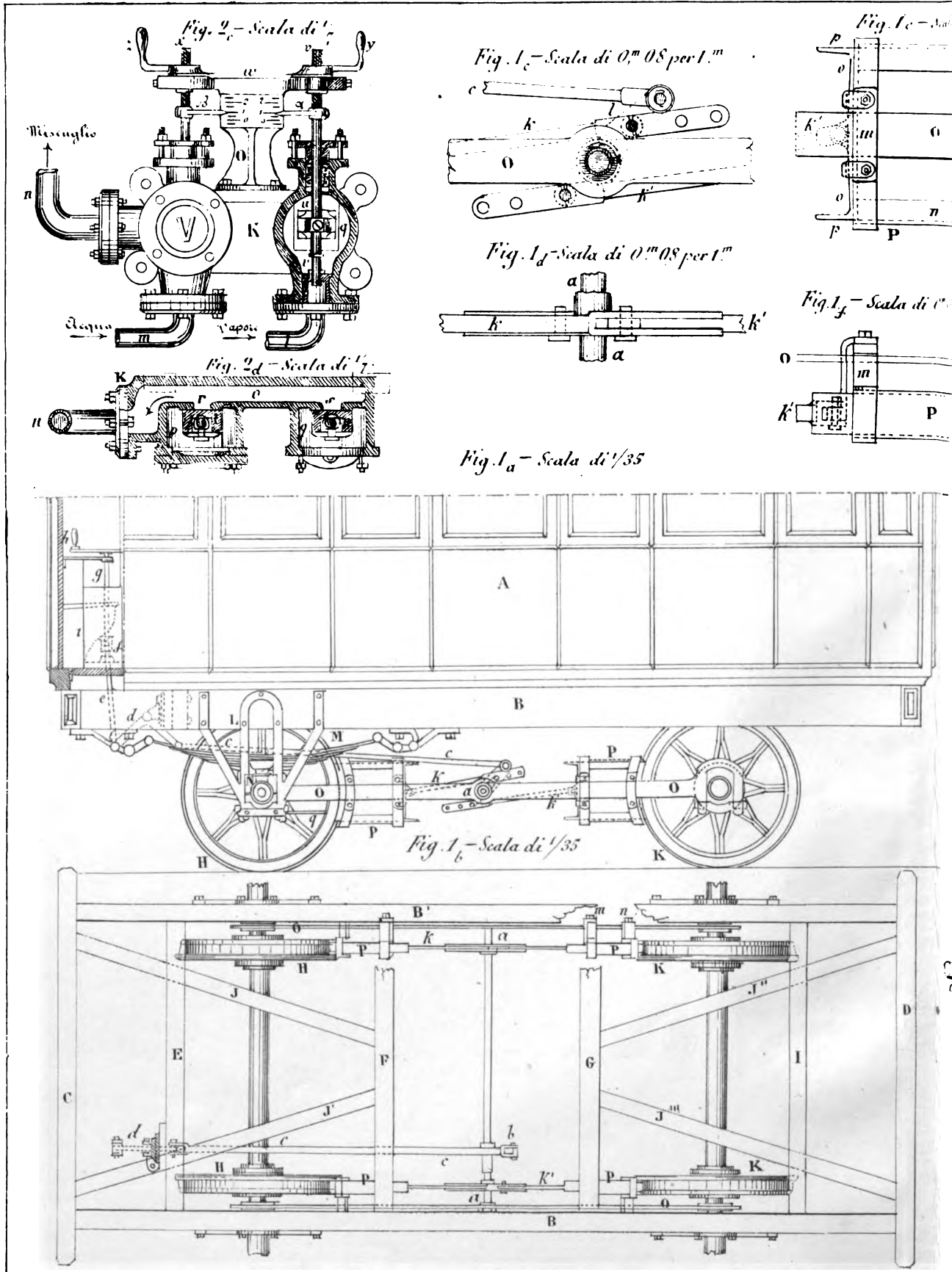
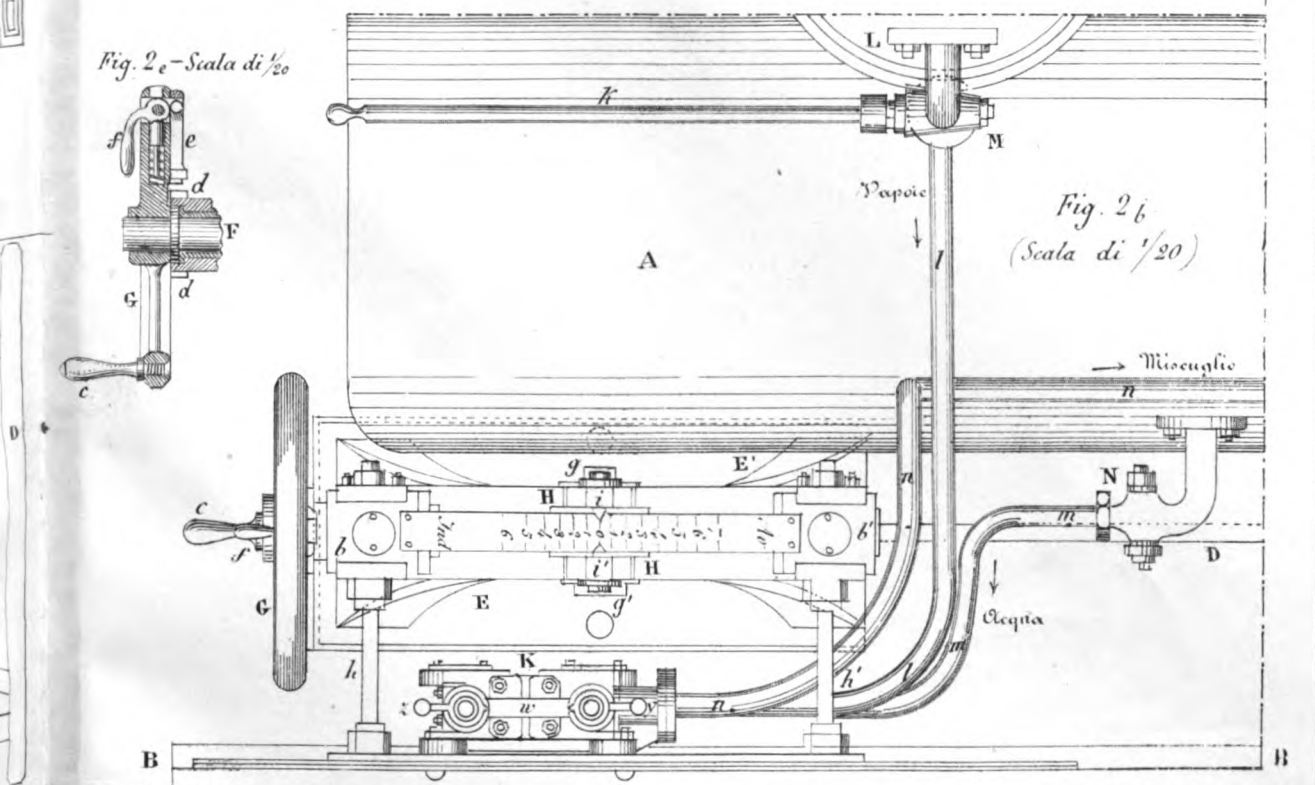
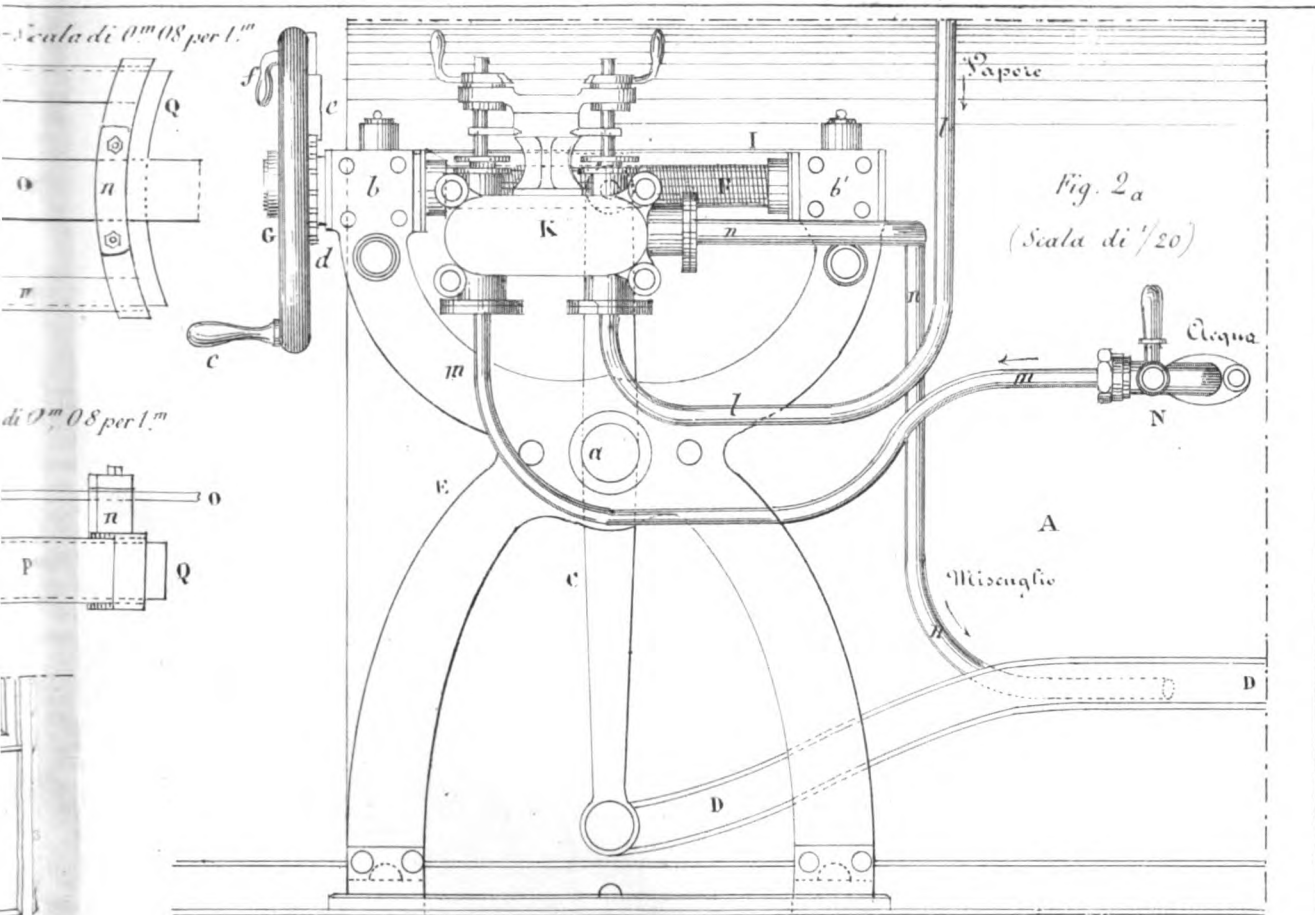

Fig. 9- Pellet (1862)

Scala di $\frac{1}{100}$.







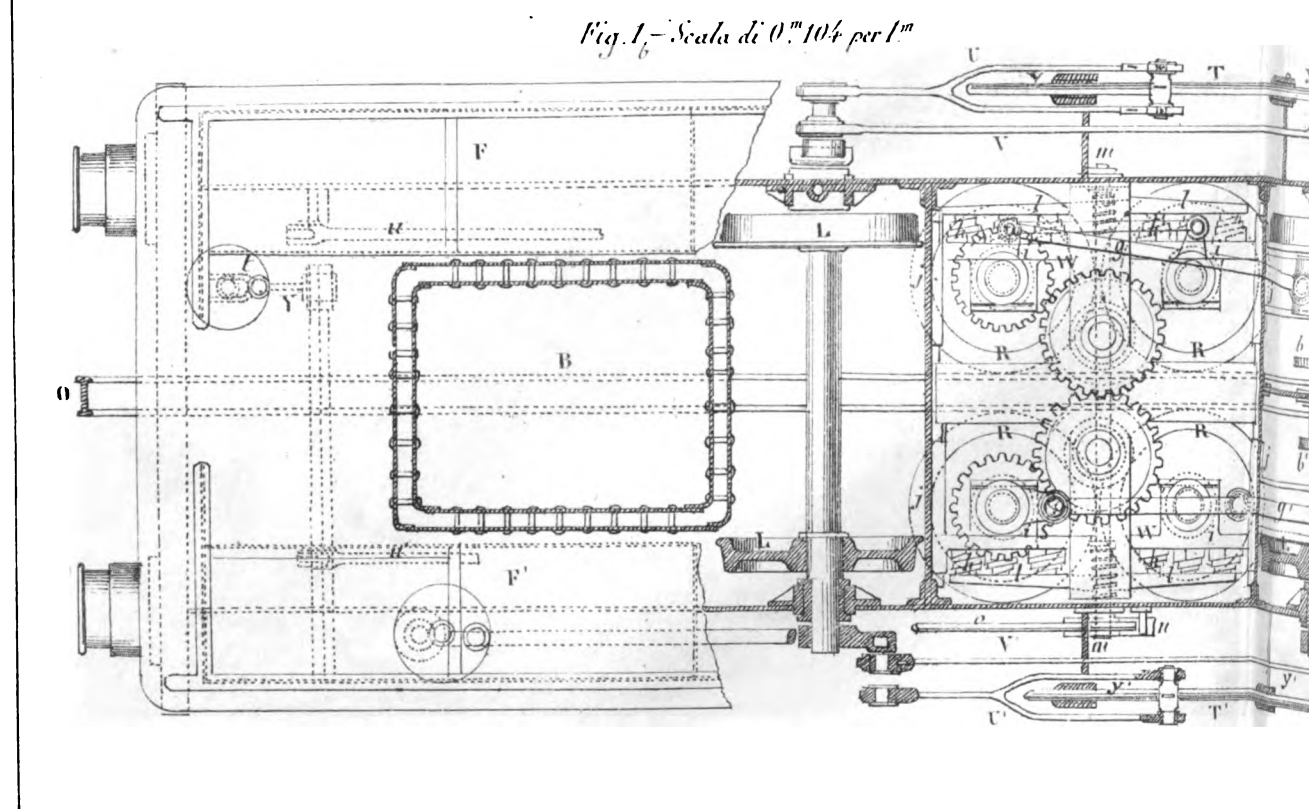
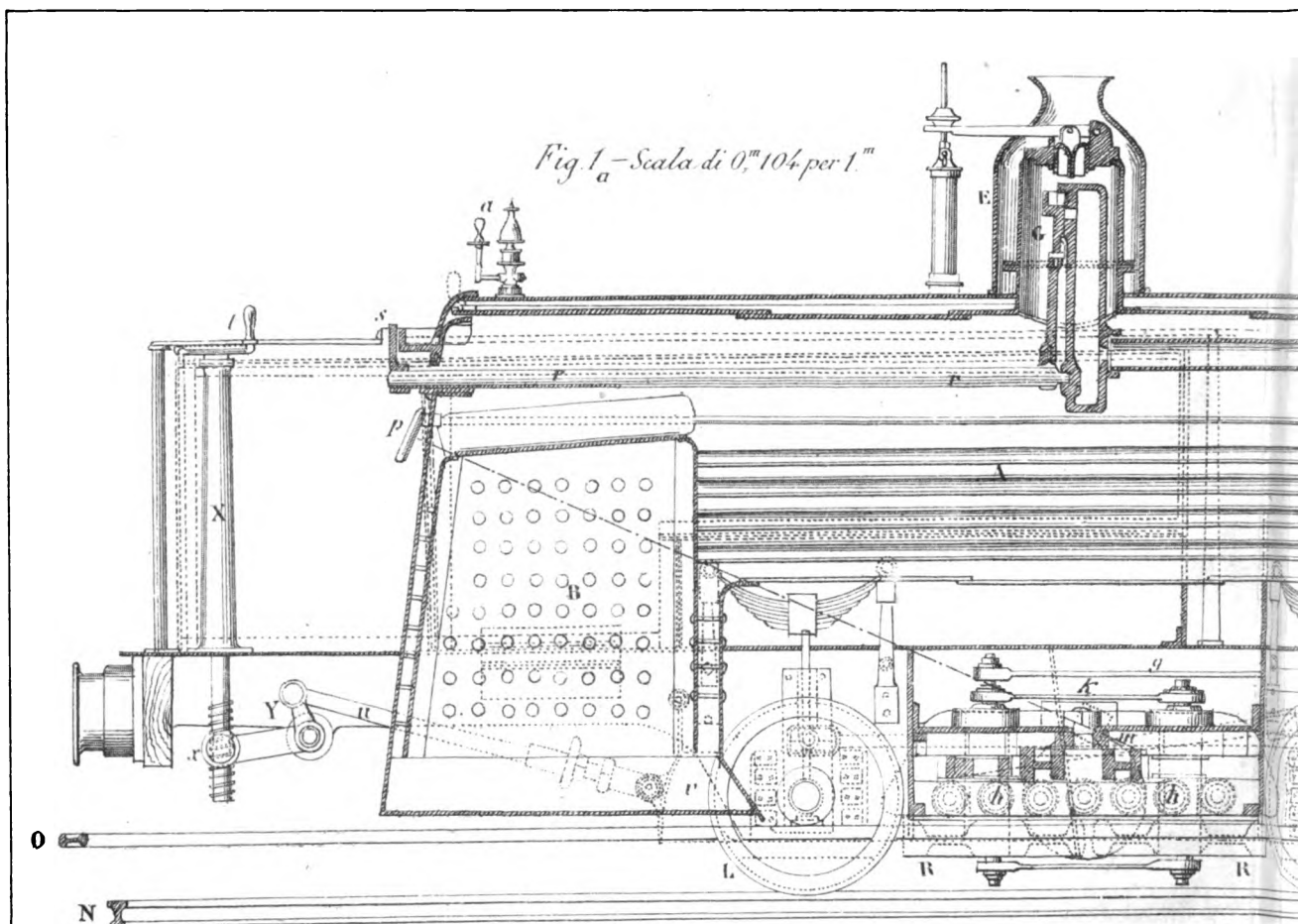

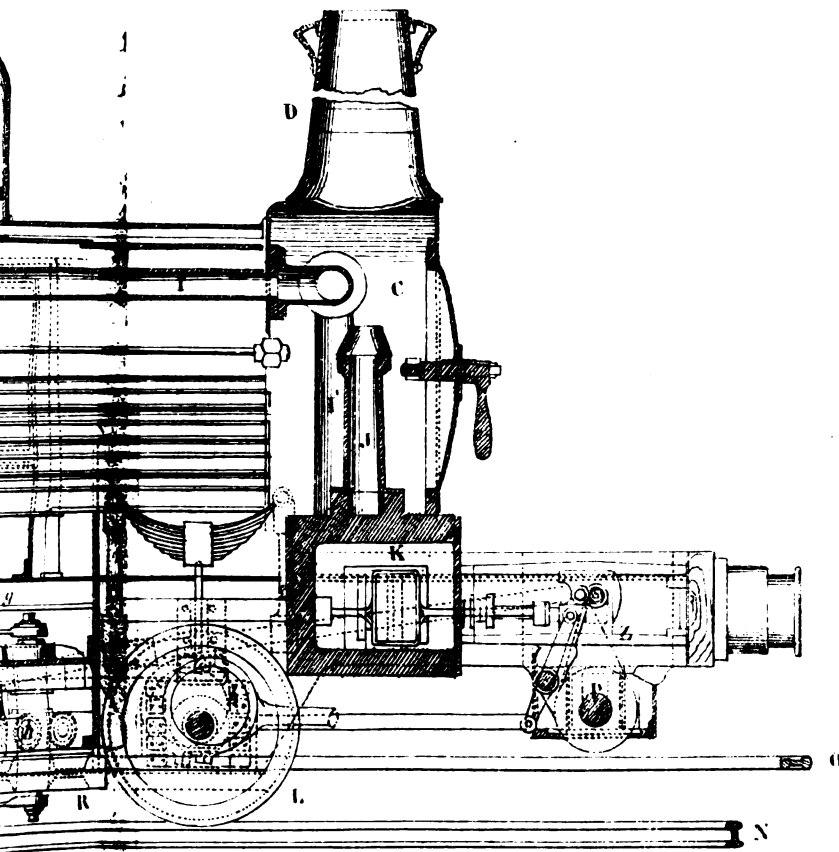

Fig 1c
(Scala di 0^m104 per 1^m)

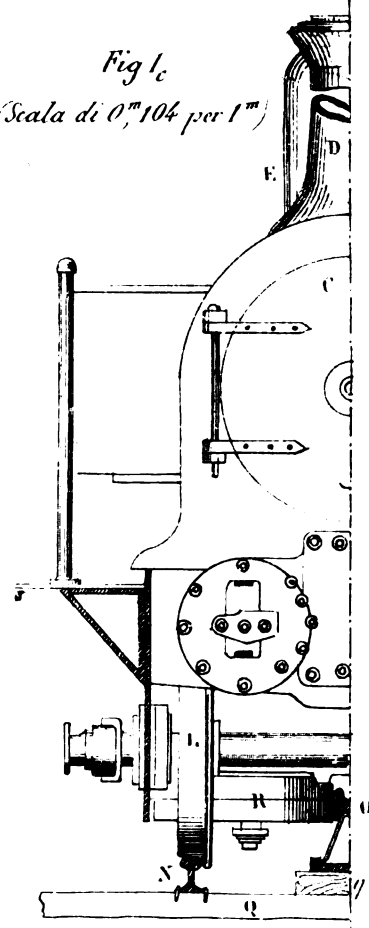
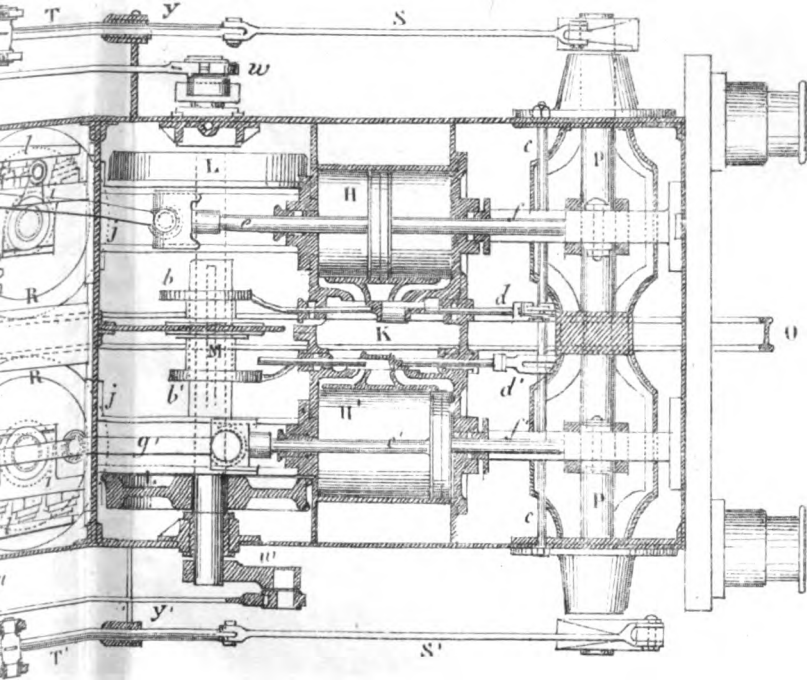
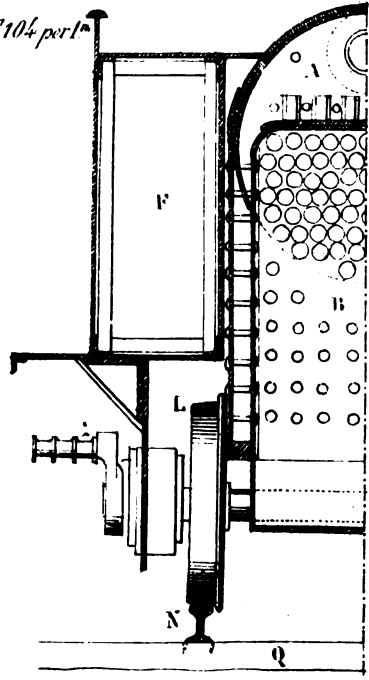
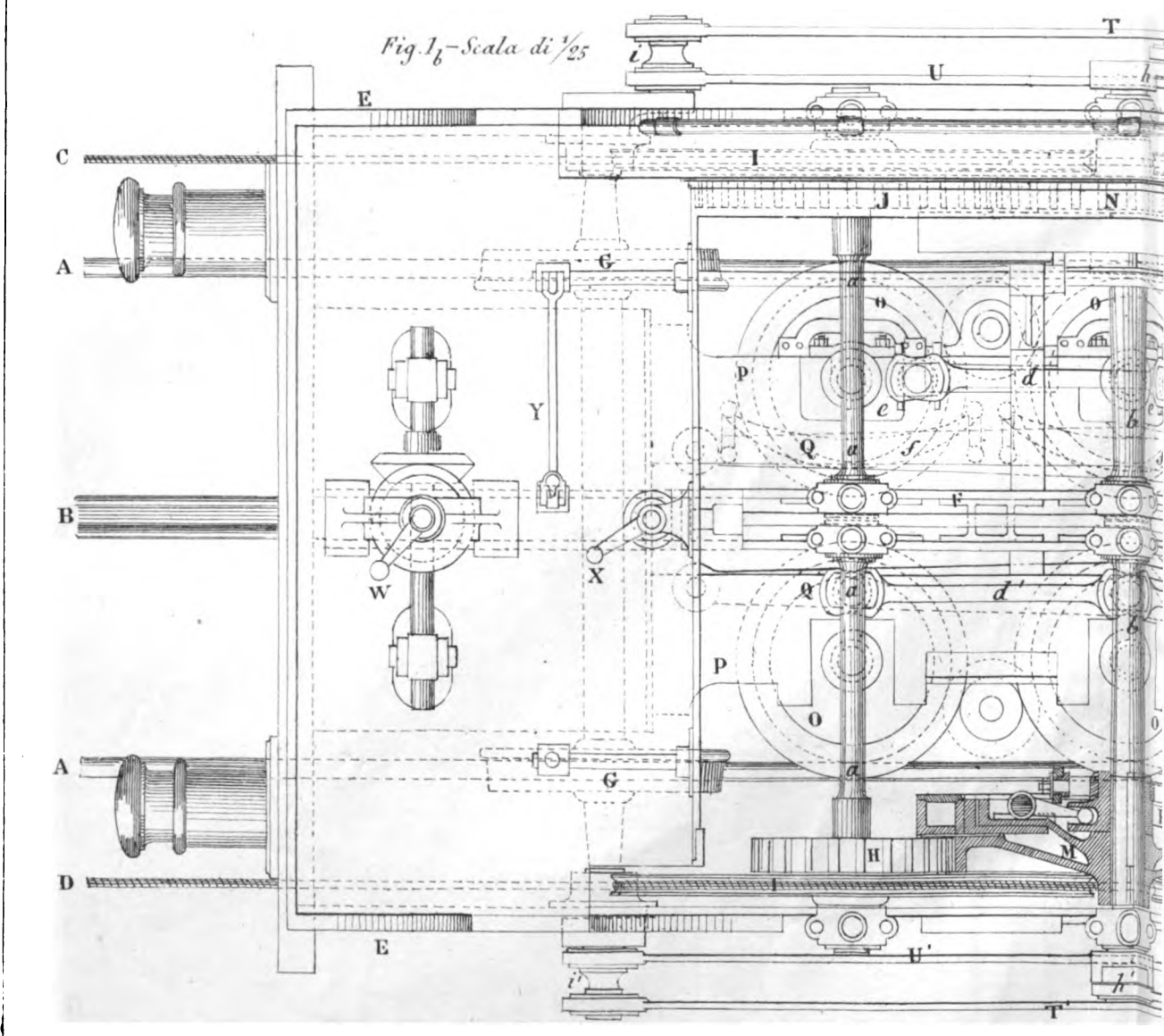
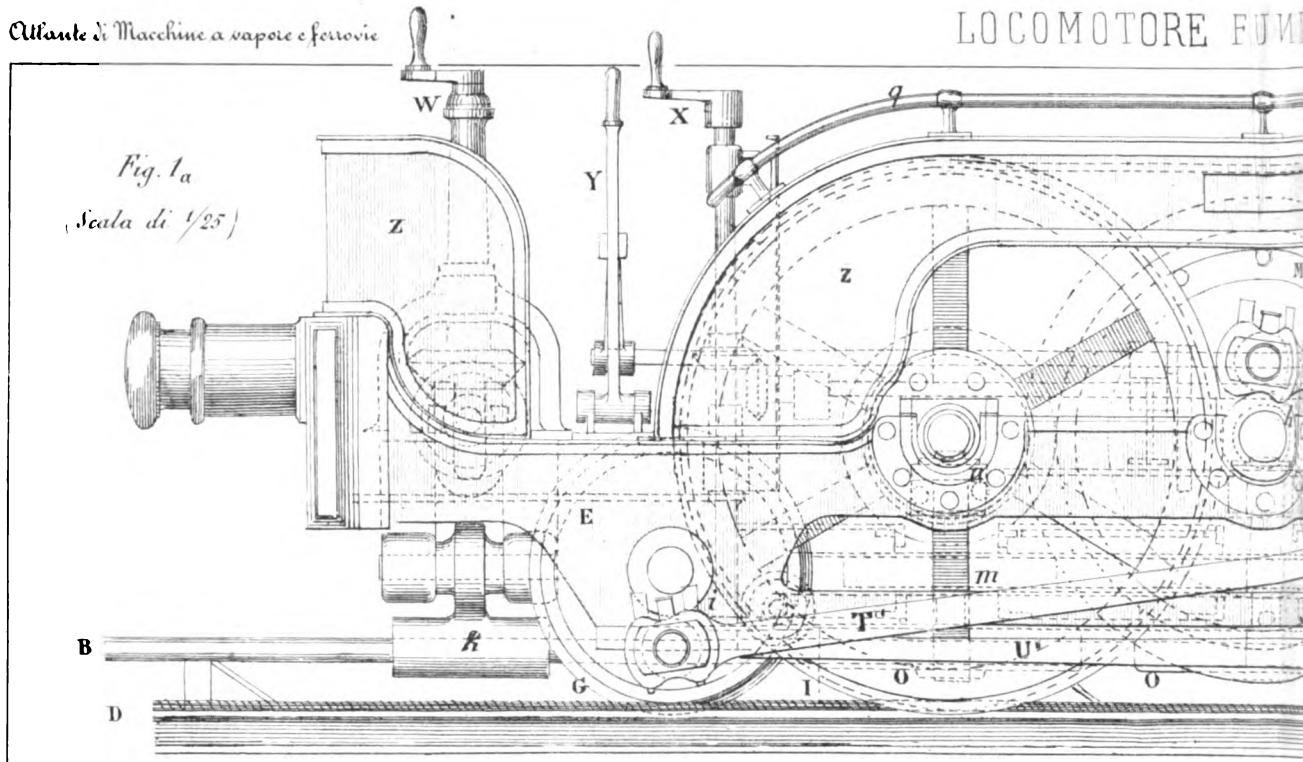
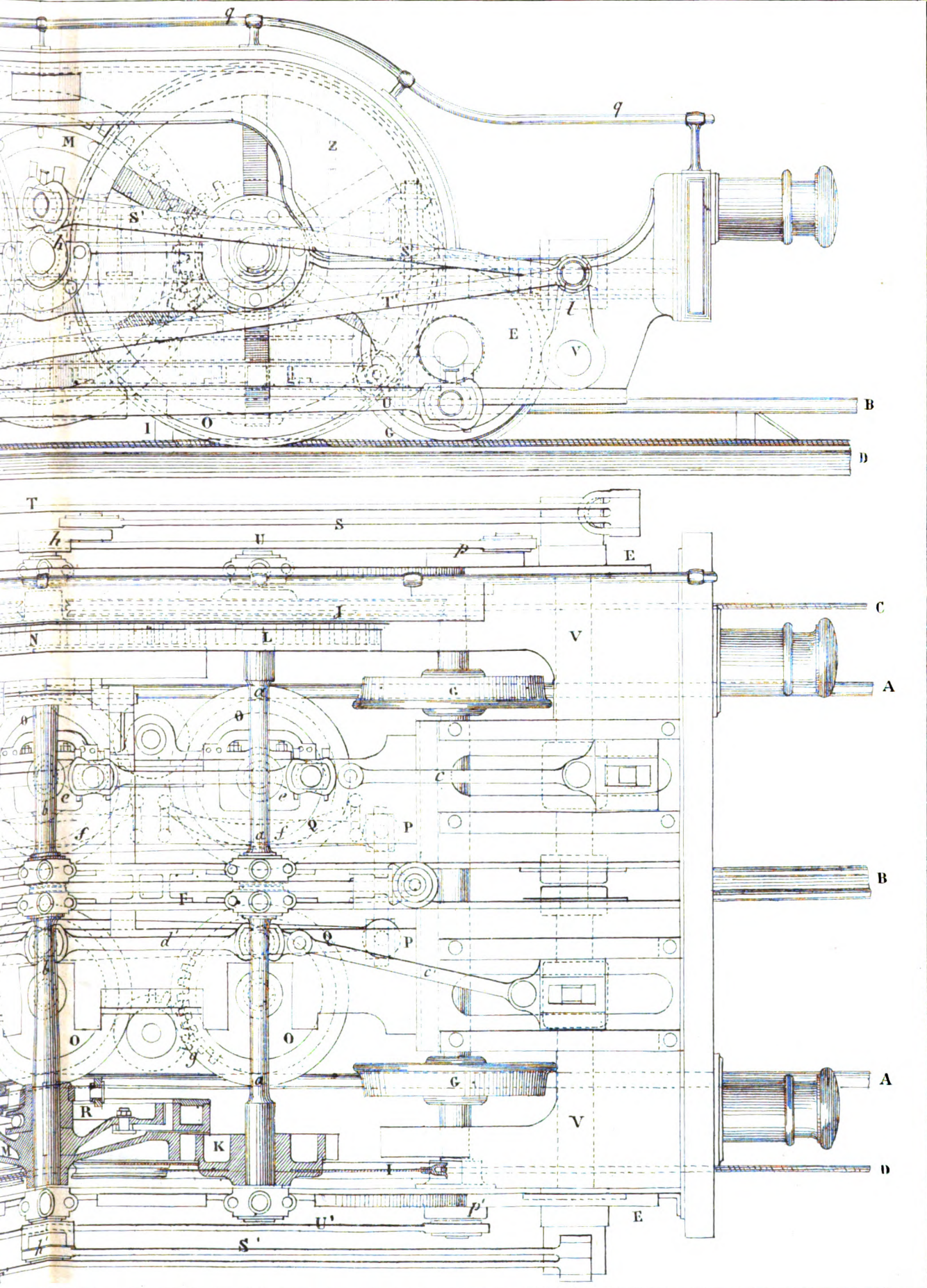

Fig 1d
(Scala di 0^m104 per 1^m)







22:51 167 13

22:51 167 13

OPERE DELLO STESSO AUTORE

Corso teorico-pratico ed elementare di disegno assonometrico applicato specialmente alle macchine ad uso delle scuole di disegno universitarie, degli Istituti tecnici e degli Operai (con 28 incisioni in legno intercalate nel testo ed un atlante di 7 tavole litografate) — *Presso G. B. Paravia e Comp. in Firenze, Torino e Milano.*

Manuale delle Macchine per isgranellare il cotone, compilato dietro invito del Presidente della Reale Commissione per la coltivazione del cotone in Italia, Commendatore GIUSEPPE DEVINCENZI Senatore del Regno: opera pubblicata sotto gli auspici del Ministero di agricoltura, industria e commercio, ed adorna di sei tavole litografate, unitamente ad una veduta prospettica della sala delle macchine della prima esposizione dei cotoni italiani fatta l'anno 1864 in Torino — *Presso G. B. Paravia e Comp. in Torino, Firenze e Milano.*

Corso di letture tecniche normali sulle Macchine motrici professato presso il R. Museo industriale italiano in Torino: pubblicazione corredata di quattro tavole autografate dall'Ing. GIO. ANGELO REYCEND — *Presso G. B. Paravia in Firenze, Torino e Milano, ed i fratelli Bocca in Firenze e Torino.*

Quadri numerici concernenti le Macchine a vapore e Ferrovie preceduti da testo esplicativo con numerose formole: opera compilata colla collaborazione de' suoi allievi, e della quale furono già pubblicate nove delle dodici serie in cui l'opera è divisa. Di quest'opera venne intrapresa una seconda edizione ampliata e corretta, la quale sarà inoltre corredata d'indice alfabetico — *Dirigersi alla tipografia editrice Fodratti (Torino, via Ospedale, 21).*

ca 30000



B. N. C. F.

B. 21. . 15



CF005712951



